

USE AND CARE GUIDE

CONDENSATE PUMP

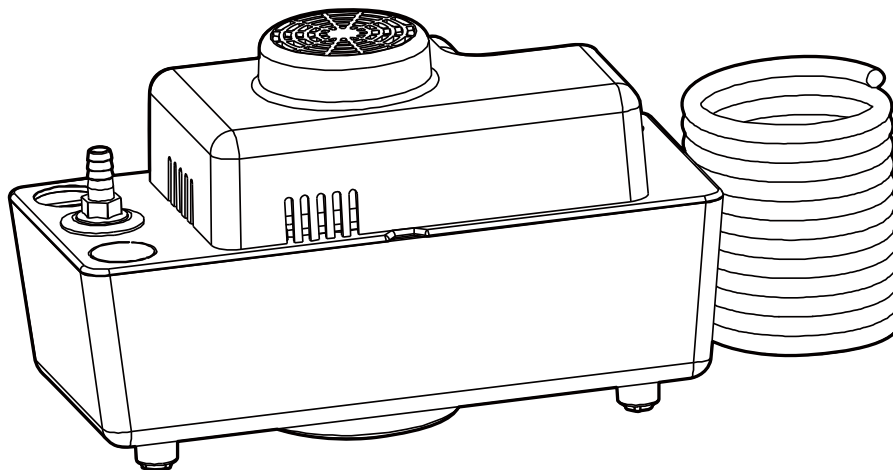

Questions, problems, missing parts? Before returning to the store call
Everbilt Customer Service
8 a.m. - 6 p.m., EST, Monday-Friday

1-844-241-5521

HOMEDEPOT.COM

Rev. 05/20/17

THANK YOU

We appreciate the trust and confidence you have placed in Everbilt through the purchase of this condensate pump. We strive to continually create quality products designed to enhance your home. Visit us online to see our full line of products available for your home improvement needs. Thank you for choosing Everbilt!

Table of Contents

Table of Contents.....2
 Performance2
 Safety Information.....2
 Warranty3
 Pre-Operation4
 APPLICATION4

TOOLS REQUIRED4
 PACKAGE CONTENTS4
 SPECIFICATIONS4
 Operation5
 Troubleshooting7

Performance

SKU	HP	GPH of Water @ Total Feet Of Lift				Max. Lift
		0 ft.	5 ft.	10 ft.	15 ft.	
1000026611	1/20	132	108	72	24	18 ft.

Safety Information



DANGER: Do not pump flammable or explosive liquids such as oil, gasoline, kerosene, ethanol, etc. Do not use in the presence of flammable or explosive vapors. Using this pump with or near flammable liquids can cause an explosion or fire, resulting in property damage, serious personal injury, and/or death.



DANGER: ALWAYS disconnect the power to the pump before servicing.



WARNING: Release all pressure and drain all water from the system before servicing any component.



WARNING: Secure the discharge line before starting the pump. An unsecured discharge line will whip, possibly causing personal injury, and/or property damage.



WARNING: Extension cords may not deliver sufficient voltage to the pump motor. Extension cords present a life threatening safety hazard if the insulation becomes damaged or the connection ends fall into water. We recommend the pump be plugged directly into an outlet.



WARNING: Wear safety goggles at all times when working with pumps.



WARNING: This unit is designed only for use on 115 volts (single phase), 60 Hz, and is equipped with an approved 3-conductor cord and 3-prong grounded plug. Do not remove the ground pin under any circumstances. The 3-prong plug must be directly inserted into a properly installed and grounded 3-prong, grounding-type receptacle. Do not use this pump with a 2-prong wall outlet. Replace the 2-prong outlet with a properly grounded 3-prong receptacle (a GFCI outlet) installed in accordance with the National Electrical Code and local codes and ordinances. All wiring should be performed by a qualified electrician.



WARNING: Protect the electrical cord from sharp objects, hot surfaces, oil, and chemicals. Avoid kinking the cord. Do not use damaged or worn cords.



WARNING: Failure to comply with the instruction and designed operation of this unit may void the warranty. **ATTEMPTING TO USE ADAMAGED PUMP** can result in property damage, serious personal injury, and/or death.



WARNING: Ensure that the electrical circuit to the pump is protected by a 10 Amp fuse or circuit breaker.



CAUTION: Do not lift the pump by the power cord.

Safety Information (continued)



CAUTION: Know the pump and its applications, limitations, and potential hazards.



CAUTION: Follow all local electrical and safety codes, along with the National Electrical Code (NEC). In addition, all Occupational Safety and Health Administration (OSHA) guidelines must be followed.



IMPORTANT: The motor of this pump has a thermal protector that will trip if the motor becomes too hot. The protector will reset itself once the motor cools down and an acceptable temperature has been reached. The pump may start unexpectedly if it is plugged in.



IMPORTANT: Ensure the electrical power source is adequate for the requirements of the pump.



IMPORTANT: Before using the pump, check the tubing for holes or excess wear, which could cause leaks, and ensure the tubing is not kinked or making sharp angles. Straight tubing allows the pump to move the greatest amount of water quickly, and also check that all tubing connections are tight to minimize leaks.



IMPORTANT: This pump is made of high-strength, corrosion-resistant materials. It will provide trouble-free service for a long time when properly installed, maintained, and used. Please carefully read the manual and follow the instructions regarding common pump problems and remedies.



IMPORTANT: This pump is fully automatic in operation. The float switch controls the pump's "ON" and "OFF".

Warranty

The manufacturer warrants the products to be free from defects in materials and workmanship for a period of two years from date of purchase. This warranty applies only to the original consumer purchaser and only to products used in normal use and service. If within two years this product is found upon examination by the manufacturer to be defective in materials or workmanship, the manufacturer's only obligation, and your exclusive remedy, is the repair or replacement of the product at the manufacturer's discretion, provided that the product has not been damaged through misuse, abuse, accident, modifications, alterations, neglect or mishandling. Your original receipt of purchase is required to determine warranty eligibility.

The purchaser must pay all labor and shipping charges necessary to replace the product covered by this warranty.

This Limited Warranty does not cover products which have been damaged as a result of an accident, misuse, abuse, negligence, alteration, improper installation or maintenance, or failure to operate in accordance with the instructions supplied with the products, or operational failures caused by corrosion, rust, or other foreign materials in the system.

Requests for service under this warranty shall be made by returning the defective product to the manufacturer as soon as possible after the discovery of any alleged defect. The manufacturer will subsequently take corrective action as promptly as reasonably possible.

The manufacturer does not warrant and especially disclaims any warranty, whether express or implied, of fitness for a particular purpose, other than the warranty contained herein. This is the exclusive remedy and any liability for any and all indirect or consequential damages or expenses whatsoever is excluded.

Some states do not allow the exclusion or limitation of incidental or consequential damages or limitations on how long an implied warranty lasts, so the above limitations or exclusions may not apply to you. This warranty gives you specific legal rights and you may also have other rights which vary from state to state.

For Professional Technical Support call 1-844-241-5521 or visit HOMEDEPOT.COM.

For warranty registration please go to www.gppumpsus.com

Pre-Operation

APPLICATION

- This non-submersible utility pump is designed for condensate removal applications. Pump water only with this pump.
- This pump has not been tested or approved for use in swimming pools or in salt-water marine areas. This pump is not designed to function as a permanently installed sump pump. It is also not engineered to run continuously as a “fountain” or “waterfall” pump.
- Do not use where water recirculates.
- Not designed for the drains of swimming pools.

FEATURES

- Operating water depth: minimum, 2-1/4 in.

TOOLS REQUIRED

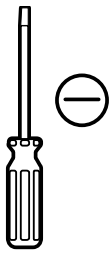

Flathead
Screwdriver

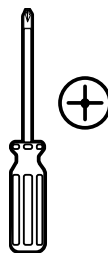

Phillips
Screwdriver



Safety Goggles

PACKAGE CONTENTS

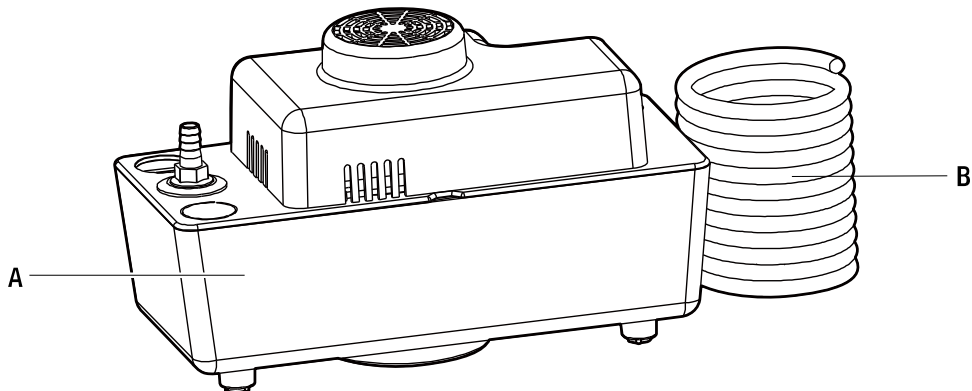

Part	Description
A	Pump
B	3/8 in.(ID)clear tubing

SPECIFICATIONS

Power supply	115V, 60 HZ., 10 Amp Circuit
Liquid Temp. Range	32°F to 95°F(0°-35°C)
Discharge	3/8 in. hose barb

Operation



NOTE: This unit is non-submersible. The pump should not be installed in a manner that will subject it to flooding, splashing or spraying.

1 Mounting the pump

- The tank has two slots (1) provided to mount the unit. The slots are located on the back of the tank. Mount the unit either on the side of the air conditioner unit or nearby wall.
- The pump must be level and the inlet must be below the coil drain. Conduit fittings are not compatible with the plastic pump housing.

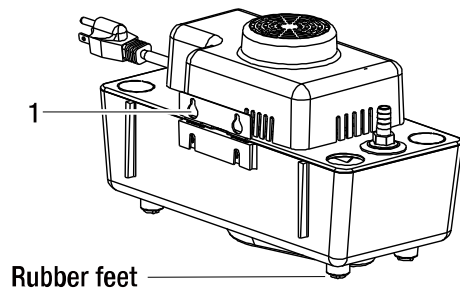

2 Connecting the air conditioning condensate drain tubing

- Ensure the tubing to the pump intake is fastened securely so that it cannot come out of the pump intake port.
- Cut the tubing at an angle so that the bottom of the reservoir does not close the tubing outlet. Be sure the tubing does not interfere with the float.

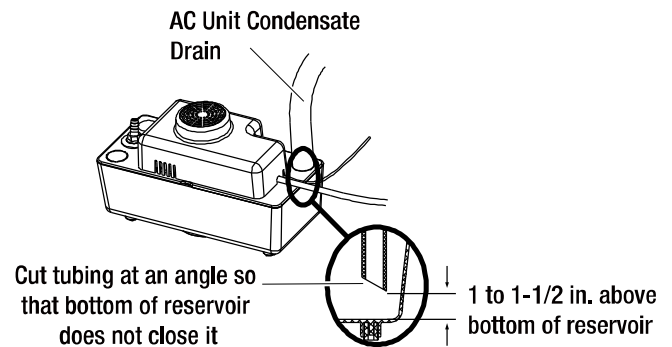

3 Connecting the tubing

- Connect the tubing from the pump discharge hose barb to the floor drain, laundry tub, or sink. Leave an air gap above the tub drain.

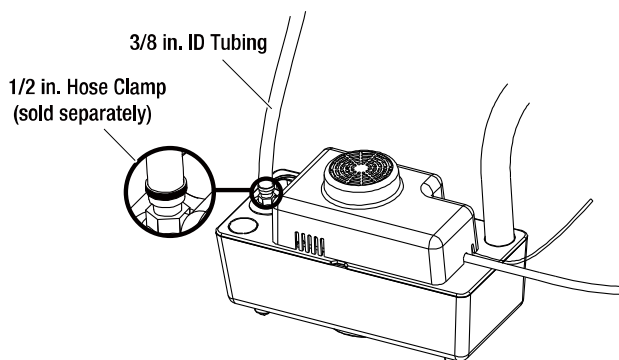

4 Plugging in the pump

- Plug the pump power cord into a 115 volt properly grounded power outlet.

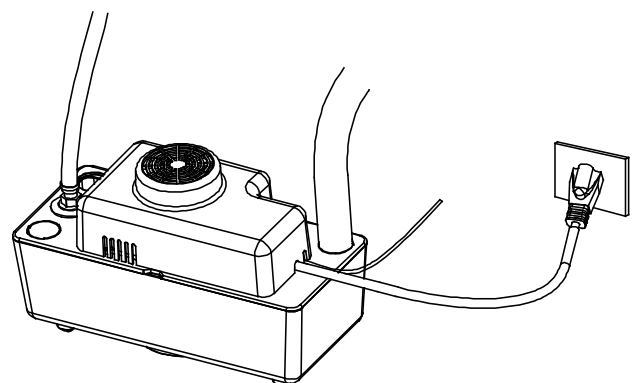

Operation (continued)

SAFETY SWITCH

The safety switch is designed to activate an alarm (sold separately) or to cut off power in the event of high water in the condensate reservoir.

To control a thermostatic circuit the COM and NO connections from the safety switch are to be wired in series with the low voltage thermostat circuit to shut down the heating/AC circuit. The COM and NC switch contacts may be used to actuate a low voltage alarm circuit (connected in series) if the heating/cooling system cannot be disrupted.

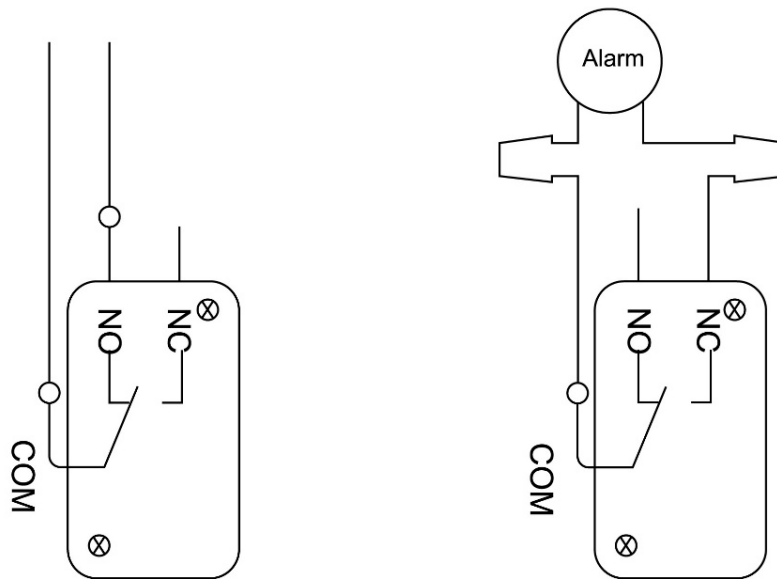

TESTING

1. Unplug the condensate pump so that it cannot pump out water. Fill water into the pump reservoir until it is almost full. The safety switch should activate before the float contacts the cover.
 2. Plug in the condensate pump. The float should activate the pump and pump the water out.
- As the water level goes down in the reservoir, the safety switch should reset, allowing the appliance to start or shut off the alarm.

Troubleshooting

Problem	Cause	Corrective Action
The pump does not start	<ol style="list-style-type: none"> 1. The house fuse is blown. 2. The breaker is tripped. 3. The plug is disconnected. 4. The plug is corroded. 5. The float is stuck. 6. Open circuit 	<ol style="list-style-type: none"> 1. If blown, replace with a fuse of proper size. 2. Reset the breaker. 3. Secure the plug. 4. Clean the plug prongs. 5. Clean the reservoir and ensure the float moves freely. 6. Have certified electrician check fuse circuit.
The pump is unable to pump out water	<ol style="list-style-type: none"> 1. The tubing is kinked, bent sharply, or coiled. 2. The tubing length is too long. 3. The float is sticking. 4. The discharge height is greater than 18 feet. 5. Obstruction in discharge tubing. 6. Blocked check valve. 	<ol style="list-style-type: none"> 1. Straighten the tubing. 2. Shorten the discharge tubing. 3. Clean any debris from reservoir. 4. Measure the height from the pump to the highest point. Rework discharge if greater than 18'. 5. Check line for blockage and remove any debris. 6. Remove any debris around check valve.
Liquid is draining back into reservoir from discharge line.	<ol style="list-style-type: none"> 1. Damaged check valve. 2. Blockage in check valve, 	<ol style="list-style-type: none"> 1. Contact Everbilt 2. Clear any debris away from check valve.
Liquid is leaking around check valve.	<ol style="list-style-type: none"> 1. Check valve is too loose or fastened too tight. 2. Damaged O-ring. 	<ol style="list-style-type: none"> 1. Check valve should be hand-tightened. 2. Contact Everbilt customer service for replacement.
My air conditioner is not blowing cool air	<ol style="list-style-type: none"> 1. Check safety switch on condensate pump to see if activated. 	<ol style="list-style-type: none"> 1. Check blockage in drainage tube, or replace condensate pump.



Questions, problems, missing parts? Before returning to the store call
Everbilt Customer Service
8 a.m. - 6 p.m., EST, Monday-Friday

1-844-241-5521

HOMEDEPOT.COM

Free Manuals Download Website

<http://myh66.com>

<http://usermanuals.us>

<http://www.somanuals.com>

<http://www.4manuals.cc>

<http://www.manual-lib.com>

<http://www.404manual.com>

<http://www.luxmanual.com>

<http://aubethermostatmanual.com>

Golf course search by state

<http://golfingnear.com>

Email search by domain

<http://emailbydomain.com>

Auto manuals search

<http://auto.somanuals.com>

TV manuals search

<http://tv.somanuals.com>