

---

# Owner's Manual

---

**READ AND SAVE THESE INSTRUCTIONS**

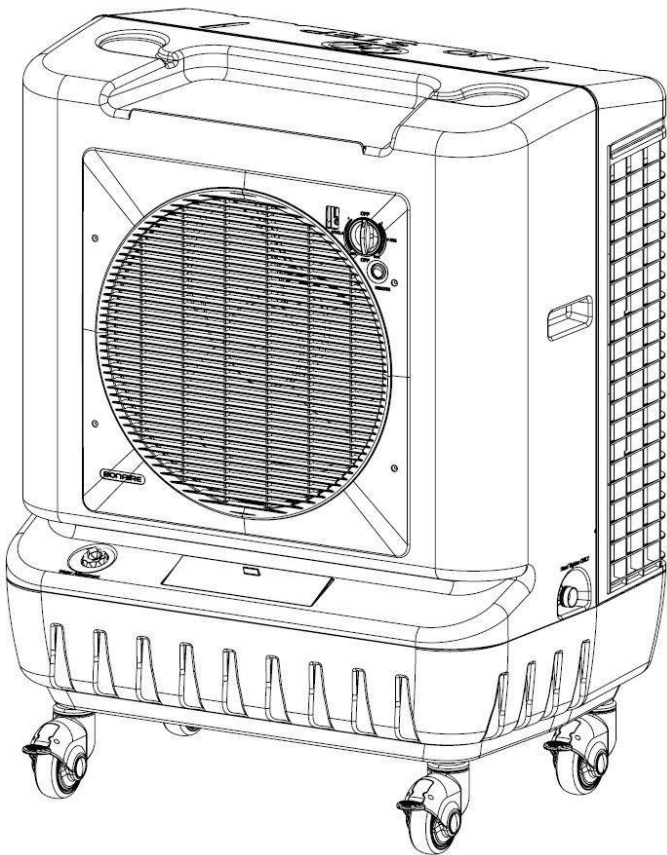

**DO NOT  
Return to store**

For help with installation or warranty issues call

800-939-2983 or [www.bonaire-usa.com](http://www.bonaire-usa.com)

For parts Visit our secure website

[www.bonairedurango.com](http://www.bonairedurango.com)

This product may qualify for up to \$300 in rebates

**Check with your local agency**

## **Durango Portable Cooler**

**Model 3500M, 4200M**

*Please keep this important manual in a safe place. It is the owner's responsibility to ensure that regular maintenance is carried out on this evaporative cooling product.*

*Failure to do so will void all guarantees beyond statutory and legal requirements.*

---



# Table of Contents

<b>Quick Setup Guide</b> .....	<b>3</b>
<b>Introduction</b> .....	<b>4</b>
General Information .....	4
Unit External View .....	5
Unit Internal View .....	6
<b>Installation</b> .....	<b>7</b>
Unpacking The Unit .....	7
Wheel Assembly .....	7
Water Connection / Tank Filling .....	8
Startup Checklist .....	9
<b>Operation Instructions</b> .....	<b>10</b>
Placement .....	10
Cooler Operation .....	10
Before Starting .....	10
Operating the Unit .....	10
Manual Mode .....	10
Auto (Remote) Mode .....	11
Bleed Off .....	12
<b>Maintenance</b> .....	<b>13</b>
General .....	14
Filter Pads .....	14
Water Tank .....	14
Water Distributor .....	14
Water Level / Float Valve .....	14
Bleed Off .....	15
Electrical .....	15
5 Year Maintenance Planner .....	16
<b>Part List</b> .....	<b>17</b>
<b>Problem Solving</b> .....	<b>18</b>
<b>Warranty</b> .....	<b>19</b>
<b>Notes</b> .....	<b>21</b>



# Quick Setup Guide

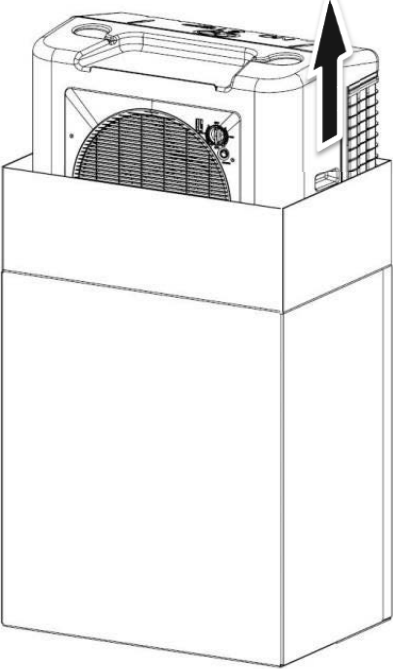

**1**

**Unpack the unit carefully**

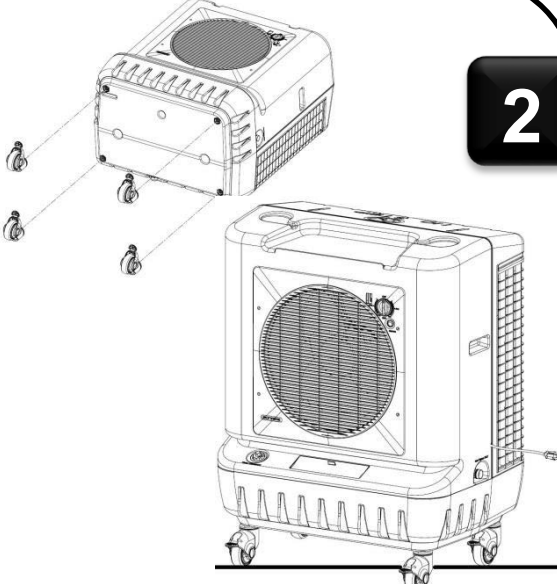

**2**

**Assemble the Wheels & Position unit on level surface**

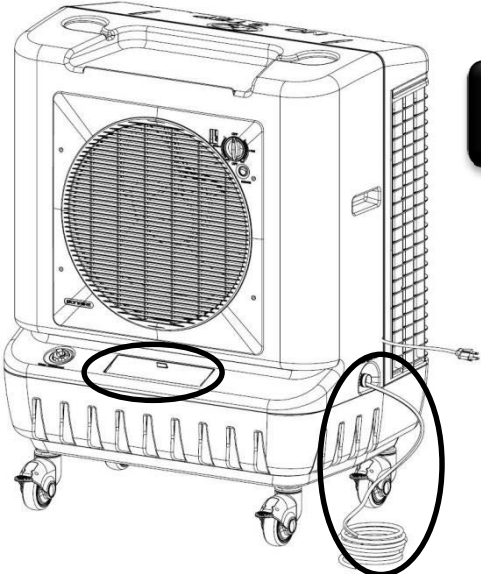

**3**

**Fill the tank or attach water hose. Lock the wheels before unit operation.**

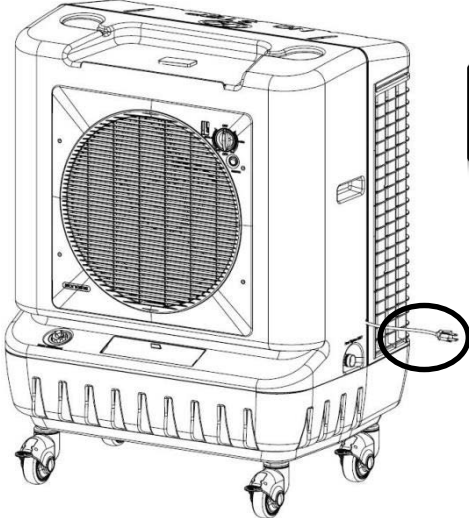

**4**

**Plug unit into appropriate outlet. Turn on power & operate unit manually or by remote. (Refer Page 10)**



## Introduction

### General Information

Thank you for purchasing a quality Bonaire Evaporative Mobile Cooler. We care about your safety and would ask you to spend a few minutes reading these simple instructions before operating this product.

## Safety!



**Read carefully all of these instructions prior to operating the unit.**

- **Read and Save these Instructions. Do not throw these Instructions away.**
- **Complete the unit assembly before attempting to operate.**
- Interference with and operation of this cooler in any manner not prescribed by these instructions could cause a safety issue and **WILL** void any warranty.
- Do not use cooler on uneven or unstable surfaces.
- Use only with a 110V 60Hz single phase grounded GFCI protected electrical receptacle.
- Do not operate cooler with Rear Filter Panel removed.
- Do not use immediately adjacent to heat sources such as stoves or radiators.
- Do not use the cooler immediately adjacent to sources of water, such as swimming pools, hot tubs, bath tubs, sinks.
- Do not operate cooler with a damaged cord, plug or other component.
- Do not run the power cord under carpet or other floor covering.
- Do not use the power cord with an adaptor plug that converts the 3 pin plug into a 2 prong connector.
- Do not use the cooler with an improperly grounded outlet.
- Do not overfill. Use water only.
- Do not alter or modify this cooler.
- Do not allow children to operate or service this cooler.
- Lock all the wheels before operating cooler.
- Do not step on or roll over power cord with heavy or sharp objects.
- Remove the plug from the electrical receptacle by pulling on the plug and not the cord.
- Never wash the unit cabinet with a garden hose: water may harm the motor and electrical system.
- **WARNING:** To reduce the risk of fire or electric shock, do not use this product with any solid state speed control device.
- Use only qualified electricians for replacement or servicing of switches, or electrical motors and components in this cooler.
- Unplug the cooler and position the rotary control knob to the OFF position when servicing or cleaning.



# Introduction

Your portable evaporative air conditioner is engineered to meet the rigors of harsh environments. Used and maintained in accordance with this manual, it will provide you with years of quiet, cool and environmentally friendly operation. Please take the time to read this manual.

The principal of your unit is to introduce fresh air, which is washed through the filter pads to provide cool fresh air. The warm stale air within the room is forced out by the cool air through open doors or windows.

## Unit External View

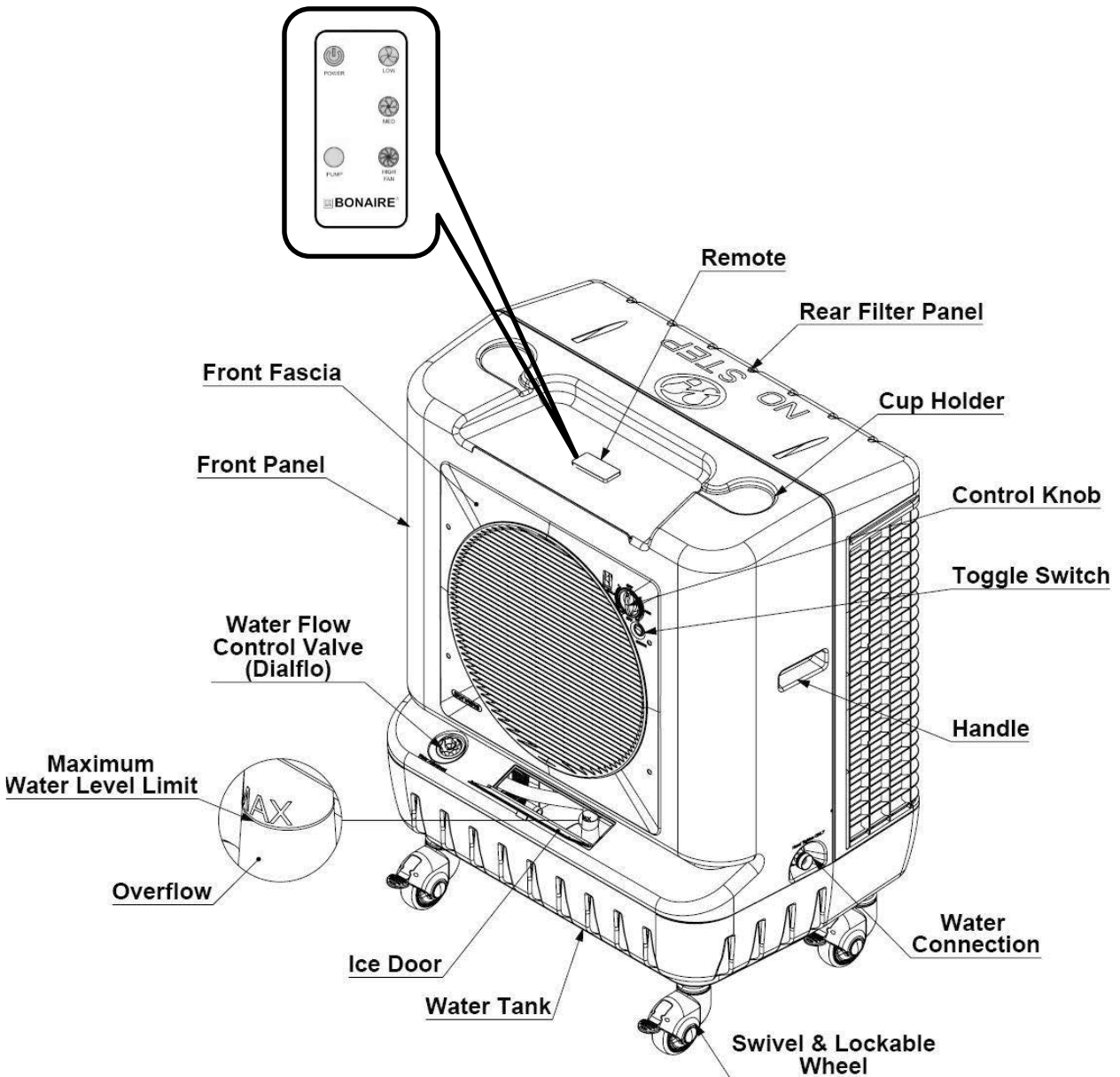



# Introduction

## Unit Internal View

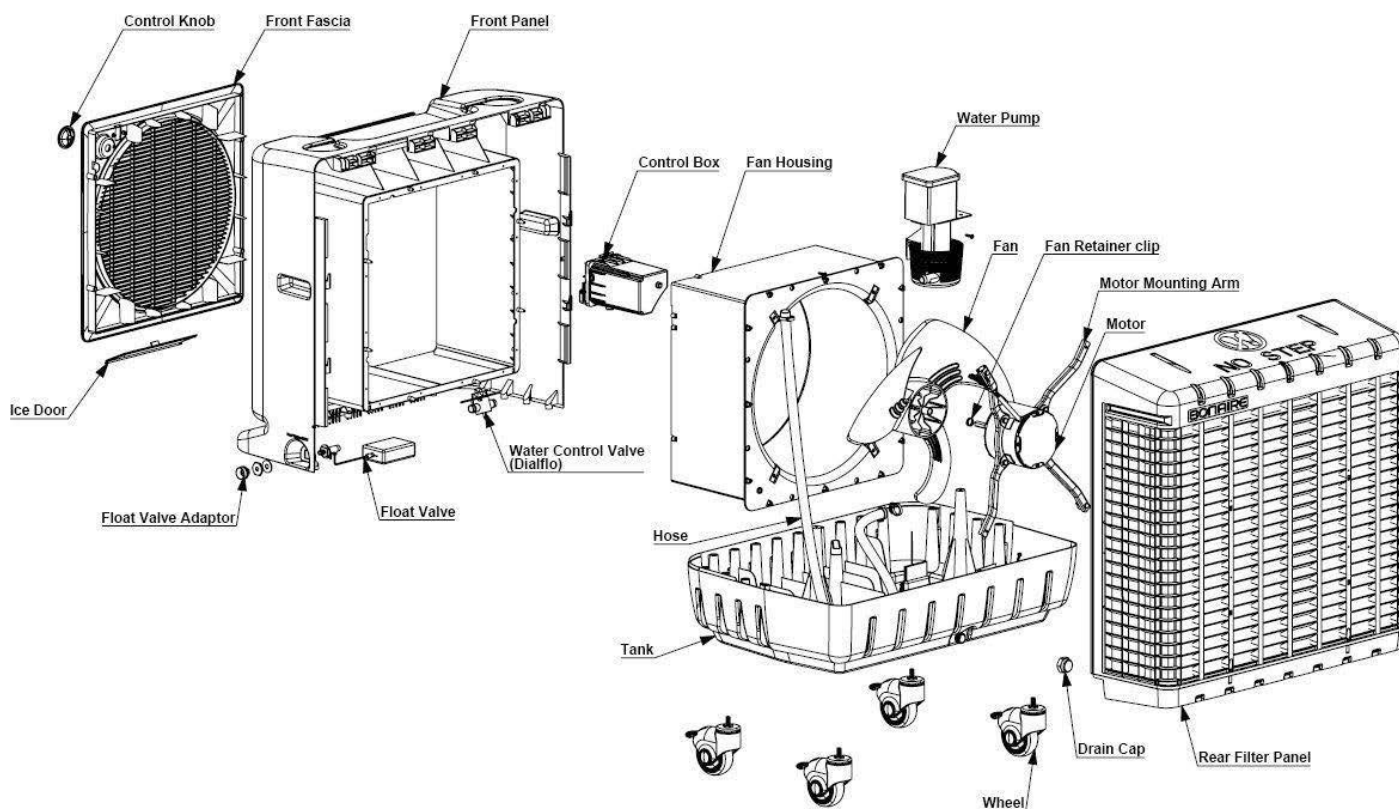

YOUR DURANGO PORTABLE COOLER UNIT WILL CONTAIN THE FOLLOWING ITEMS FOR ASSEMBLY AND OPERATION

Item Description	Quantity
Wheels	4
Spanner	1
Remote	1



# Installation

## Unpacking The Unit



### Important

When you receive your unit the wheels, remote and accessory bag will be located inside the box.

## Wheel Assembly

**Before installing the wheels the unit MUST be laid down as shown.**

As shown in the picture, lie down the unit carefully and place the wheel screw end in to the recess under the tank as shown. Then tighten the wheel in by using the spanner. Once all 4 wheels are assembled then carefully stand up the unit without damaging a rear filter panel.

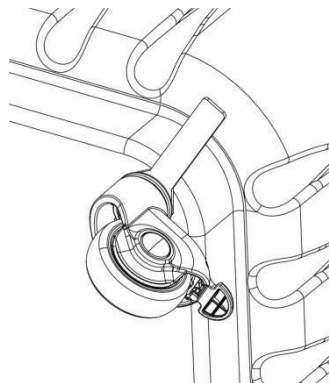
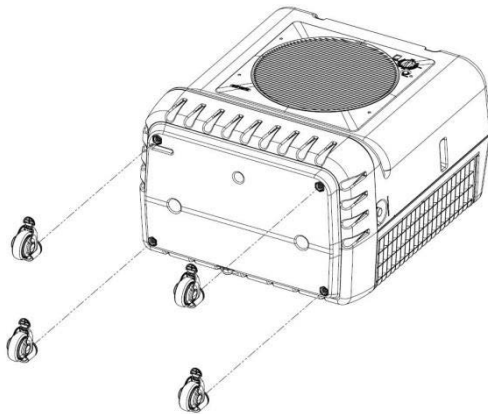
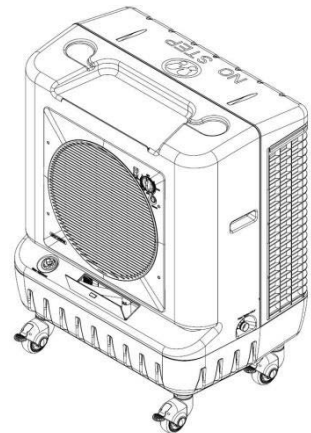

**Spanner**

**Note:** Wheels must be locked when operating the unit. To lock and unlock the wheels please refer the picture.

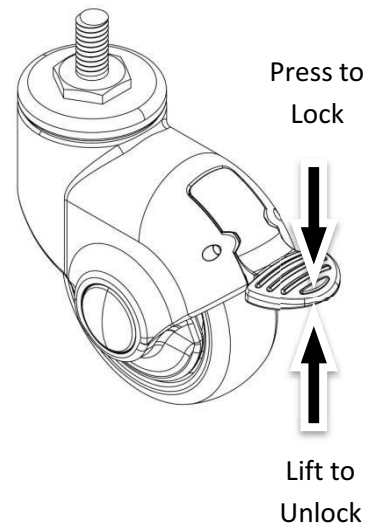

Press to Lock

Lift to Unlock



# Installation

## Water Connection / Tank Filling

This unit is compatible with a standard garden hose connection. Use standard 3/4" connection to connect water to the unit.

The overflow is factory fitted. If unit is inside then bleed hose should be kept inside the tank and regular draining of the tank will be required. If unit is outside then bleed hose should place through the overflow fitting SHOULD bleed water during normal operation at a rate between 6 – 12 Litres per hour (1.5 – 3 gallons per hour). This is normal and is designed to preserve the quality of the Cooler and Cooling efficiency of the Unit.

The float valve is factory set and should require no further adjustment at time of installation.

As an alternative to hose connection, the tank can be manually filled through the ice door of the front of the unit. The water level should be set its maximum limit as shown on overflow.

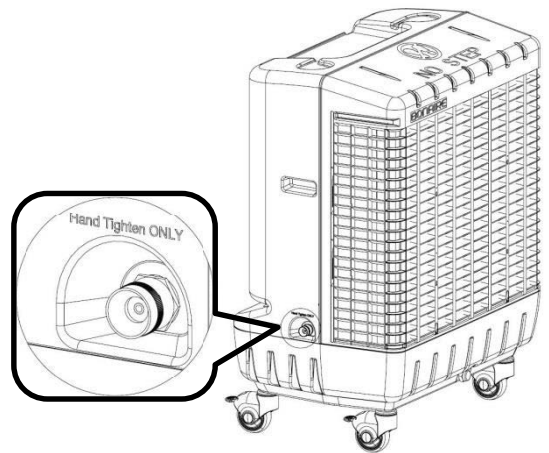

**Hose Connection**

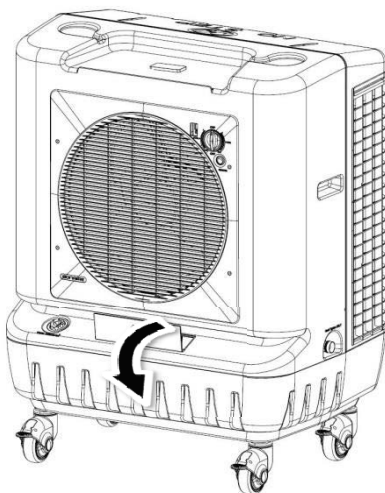

**1. Open the Ice door**

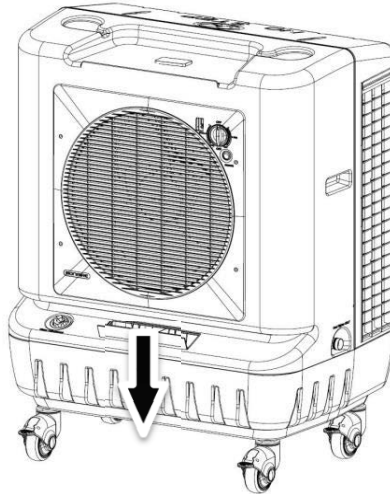

**2. Slide down the Ice door**

**Note:** Water supply line to float valve must be flushed before connecting.

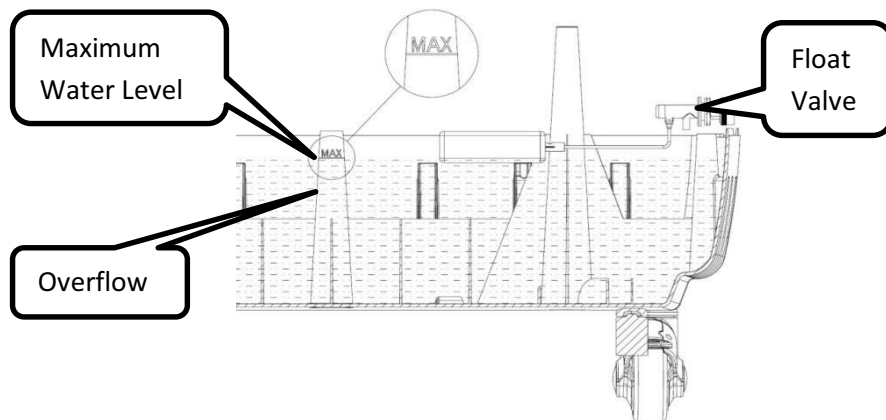





## **Startup Checklist**

- Position the cooler as required and lock all of the wheels.
- Check that another door or window in the room is open to allow air to exhaust to other parts of the house.
- Turn the water supply to the cooler on if hose connected or fill the tank with water.
- Plug the cooler into a 110V 60Hz single phase grounded appliance socket and switch the socket on.
- Turn the unit on to FAN mode and check the operation of the three speeds fan.
- Rotate the control knob to COOL mode and operate the three speed fan and pump.
- Leaving the unit in the COOL mode, check that a constant small stream of bleed off water is coming from the overflow tube if unit is outside. This bleed off is designed to reduce mineral build up on the CELdek® filter pads.
- You may notice a wet paper smell as the water circulates around the filter pads. This is normal during the commissioning phase and at the beginning of each season when the unit is operated after the winter break. It will only last for a short time.



# Operation Instructions

## Placement

It is essential for successful operation of the evaporative cooler that there be sufficient free air openings in the room to be cooled – approximately 0.5m<sup>2</sup> (5.4<sup>2</sup> feet). Open doors and windows will usually provide this. Your cooler must be positioned in front of an open window or door if it is to operate effectively. Always ensure that there is another open window or door through which the air can exhaust from the room.

## Cooler Operation

### **Before Starting**

- Always ensure that there is another open window or door through which the air can exhaust to other parts of the house.
- Ensure that the filters are kept clean.
- Ensure that the water to the cooler is turned on or that the tank has been manually filled with water.
- Ensure the plug is connected to a 110V 60Hz single phase grounded appliance socket on the inside of the house and turned on.
- **IMPORTANT.** After the first 10 hours of operation in COOL mode, the water must be drained from the unit water tank to remove any new product residuals. This process must be repeated after a further 10 hours of COOL mode operation.
- **IMPORTANT:** Wheels **MUST BE** locked while operation unit.

## Operating the Unit

The Durango Portable Cooler can be operated in either Manual or Auto (Remote) mode. This is selectable by the toggle switch on the front panel. Each mode has COOL and FAN functions are available.

### **Manual Mode:**

- **COOL Mode:** - Move control knob to “COOL” side.  
Select desired fan speed

- 1 – Low/Sleep Mode**
- 2 - Normal Operation**
- Max - Quick Cool down**

The unit will now operate with the fan motor and water pump activated.

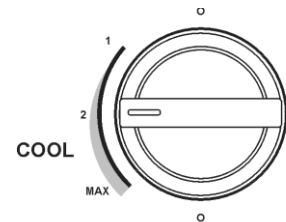

- **FAN Mode:** - Move the control knob to the “FAN” side (pump isolated). Select desired fan speed

- 1 – Low/Sleep Mode**
- 2 - Normal Operation**
- Max - Quick Cool down**

The unit will now operate with the fan motor only activated.

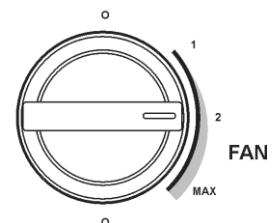

- To turn the unit off, rotate the control knob to the “O” position



# Operation Instructions

**Auto (Remote) Mode:** To activate the Auto mode turn on the switch as shown.

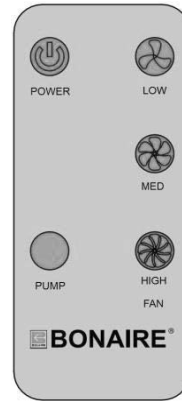
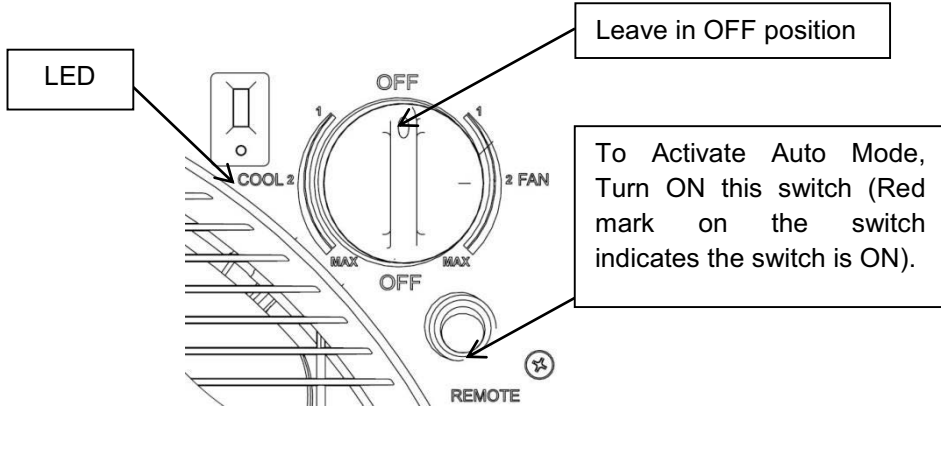

- **COOL Mode: -**

1. Press the **POWER** button and the unit will start.
2. Now press the **PUMP** button and the blue LED will be illuminated.
3. Press the fan speed button as shown according to your comfort.

The unit will now operate with the fan motor, water pump.  
To turn the unit off, press the power button.

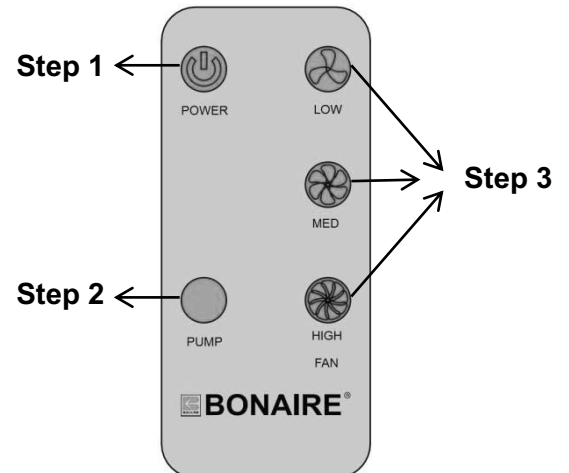

- **FAN Mode: -** Fan mode can be activated by pressing the PUMP button on and off.

1. Press the **POWER** button and the unit will start.
2. Press the fan speed button according to your comfort. (**Note:** Do not press the PUMP button)

The unit will now operate with the fan motor only activated.

To turn the unit off, press the **POWER** button.

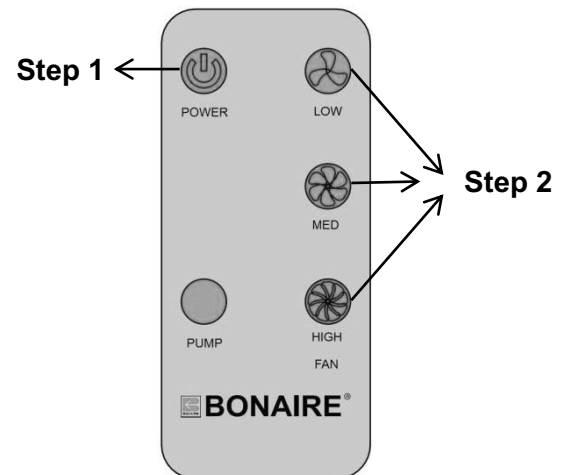



# Operation Instructions

## Bleed Off

The bleed off rate is factory preset and is adjustable. It is critical to the life of the product that the bleed off function is not restricted in any way as this may void unit warranty and will cause damage to your filters and cooler.



The function of the bleed off must be inspected by the owner on a regular basis to ensure the bleed off continuously flows when the unit is operating "COOL" mode.

## Setting the BLEED OFF Rate

To set the bleed rate locate the patented DIALFLO externally on front panel. Rotate the BLEED knob clockwise for more flow and anti-clockwise for less flow.

**Note:** Hold the water flow knob while setting the bleed rate as the water flow rate may go out of adjustment. It is recommended that the bleed water is plumbed away to waste in accordance with local and state plumbing requirements.

## Setting the Water Flow Rate

To set the water flow rate to the filter pads, rotate water flow knob anti-clockwise for more water and clockwise for less water.

**Note:** Hold the bleed knob while setting the water flow rate as the bleed rate may go out of adjustment.

All evaporative coolers require water bleed-off to prevent build-up of mineral deposits as the result of the evaporative cooling process. This will maximize the life of the premium CELdek® filter pads and minimize mineral deposits inside the cooler. The bleed off function only operates in COOL mode (when the water pump operates).

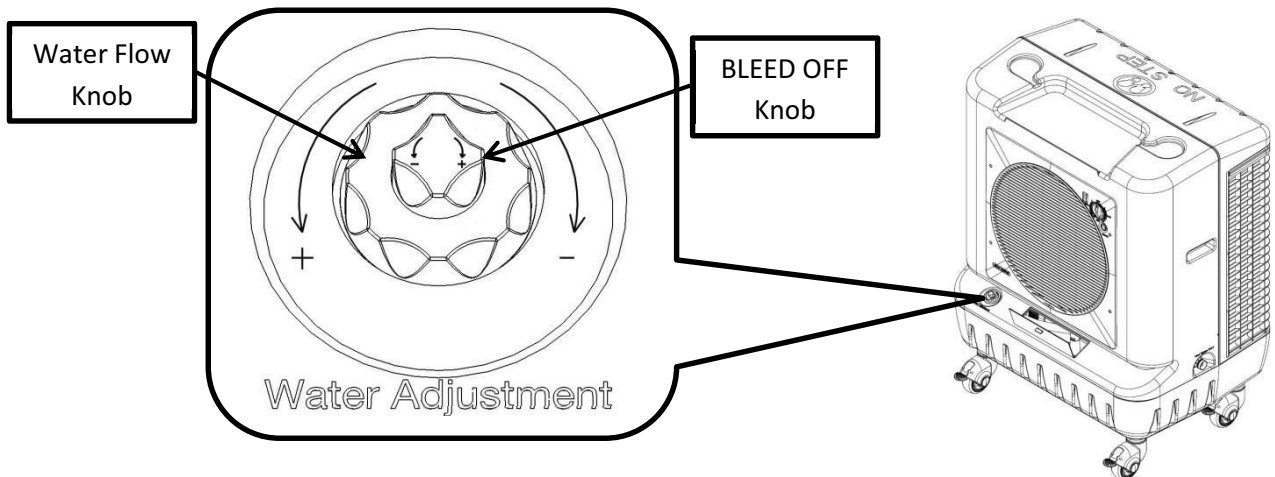

**Please Note:** - Any additional pipe work fitted to the bleed off by the owner must slope away from the unit in a downhill manner.

If water discharge is not an option because of location or cost of water, you may coil the bleed hose inside the cooler opposite the Float Valve so the water recirculates back into the tank. Please be aware that this will result in the CELdek® Pads needing to be changed more frequently.



# Maintenance



**Before commencing any maintenance work on your unit, ensure it is disconnected from the power supply.**

**Note:** It is essential that your evaporative air conditioner is maintained in accordance with this manual. Failure to do so will affect the life of the product and reduce the level of efficiency.

THIS MANUAL CONTAINS A 5 YEAR MAINTENANCE PLANNER TO USE IN CONJUNCTION WITH THESE INSTRUCTIONS. See page 16.

### Step 1

Remove Rear Filter Panel fixing screws (4 off).

### Step 2

Lift the rear filter panel in a vertical fashion 3" or 75mm.

### Step 3

Remove the hose connected to the rear filter panel and pull rear filter panel away from unit. (Note: When reinstalling the back panel the pump hose will need to be reconnected to the rear filter panel)

**Step: 1**

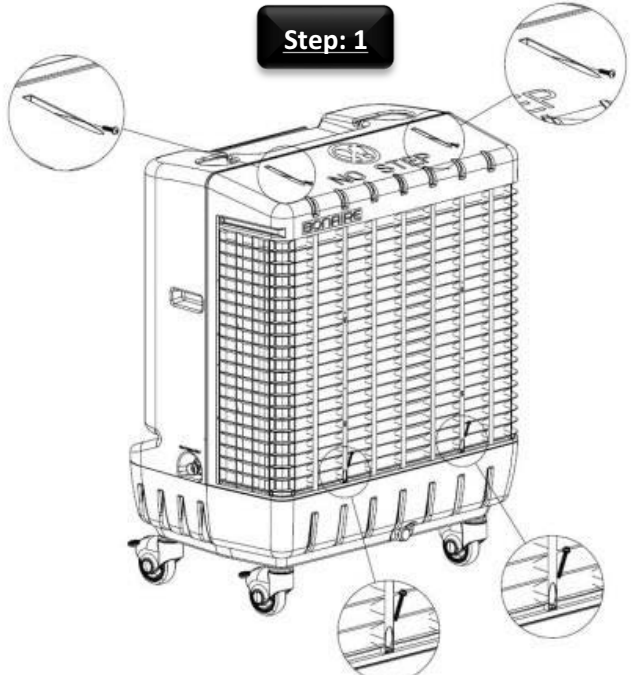

**Step: 2**

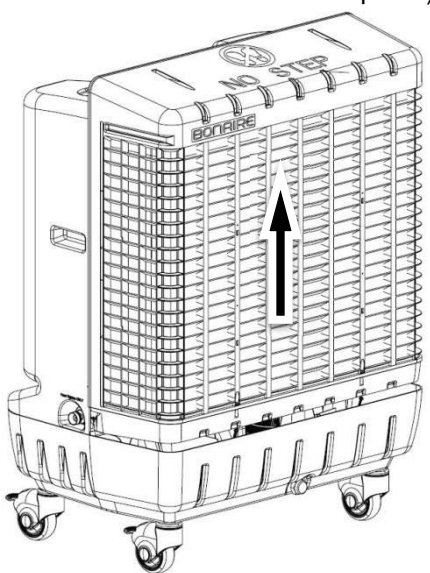

**Step: 3**

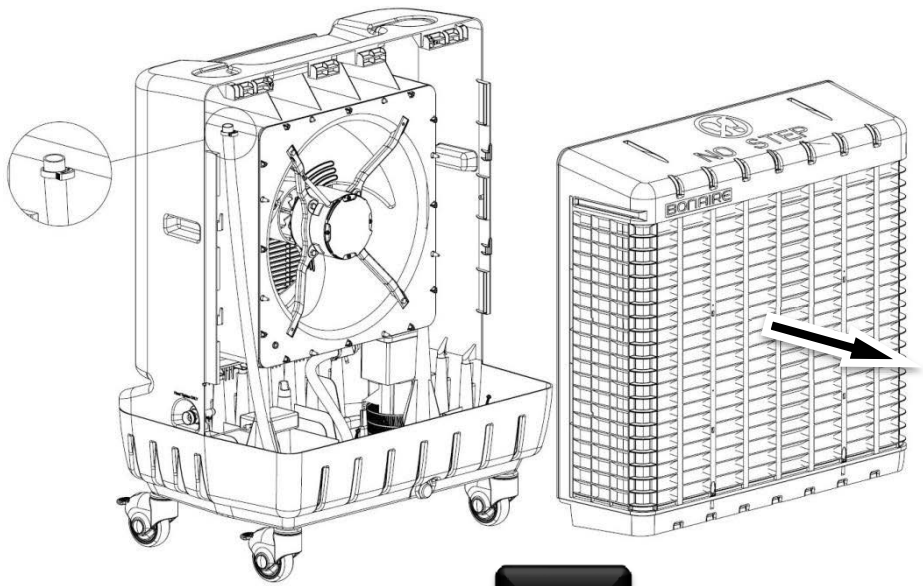

## Maintenance

### General

#### Filter Pads

Visually check CELdek® pads for damage or blockage. Gently hose down pads from both sides to remove any build up of salts, dust and pollen. In dusty areas more regular cleaning is recommended. Check the water distributor, making sure it is clear and free from blockage. Failure to do so may lead to uneven water distribution and therefore less efficient operation.

#### Water Tank

It is important to keep the water tank clean and free from sediment and algae growth. Using a small soft bristle brush, brush all surfaces in the tank while it is full of water (DO NOT FORGET THE PUMP STRAINER). Turn off the water inlet to the unit (an isolation valve should be fitted to the water inlet before the float valve or at the water supply faucet). Drain the tank by undoing the drain CAP as shown (DO NOT FORGET TO PUT THE DRAIN PLUG BACK ON AFTER DRAINING THE TANK). After refilling, it may be necessary to repeat this procedure if the tank is very dirty.

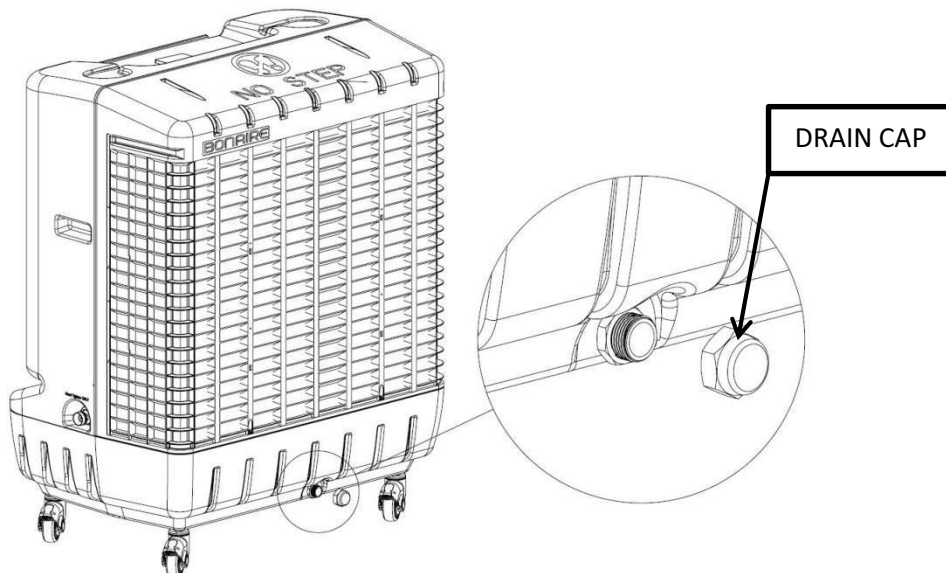

#### Water Distributor

Check the water distribution system for blockage. Check the delivery tube for kinks or holes.

Note: Water supply line to float valve must be flushed before connecting.

#### Water Level / Float Valve

The water level should be set its maximum limit as shown on overflow. The float valve is a mechanical type and is factory set. If it requires adjustment keep bends tight. If the valve is leaking, it may require replacement.

**Note: Water supply line to float valve must be flushed before connecting.**

#### Motor and Fan

Check that the fan spins freely and that there is no build up on the blades. Check the motor for corrosion and spray with an anti-corrosive agent if necessary.



# Maintenance

## Bleed Off

The bleed off should be checked to ensure it runs continuously and that there is no buildup of mineral deposits in or on your air conditioner. White deposits indicate high mineral content and the bleed off system should be checked.

In areas of poor water quality (where total dissolved solids are greater than 300 p.p.m.) increase the bleed rate.

## Pump Operation

Check the pump spins freely and that the strainer is clean. Ensure the water slinger washer is in place on the stainless steel shaft under the motor above the water line.

After a long idle period, the pump may stop rotating due to a mineral build up on the stainless shaft adjacent to the motor. To free the pump shaft, remove mineral build up and rotate the shaft using fingers or suitable sized pliers. See diagram.

Spraying the area with suitable water displacement lubricate (such as WD-40®) may assist.

**In areas of low voltage, the pump may not provide enough water to wet the filters. To rectify, increase the water flow rate by turning Dialflo.**



## Electrical



**No general maintenance is required to the electrical system.**

**Electrical connections and maintenance should only be carried out by a qualified electrician.**

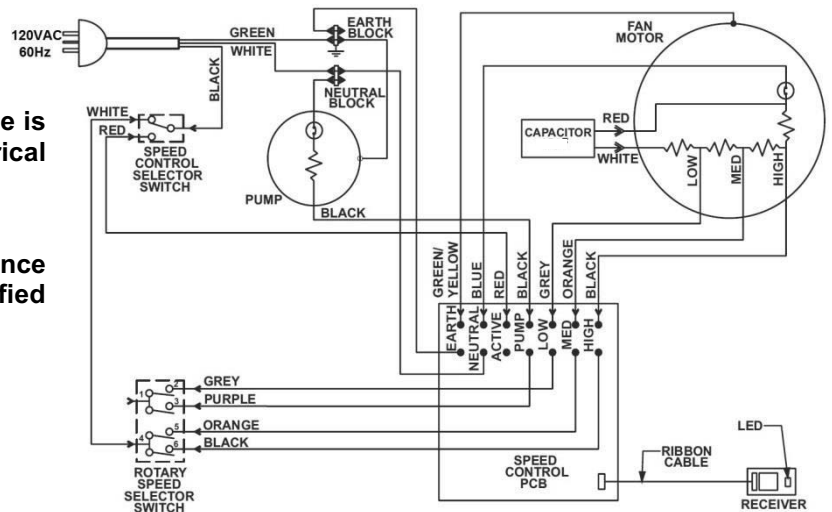



# Maintenance

## 5 Year Maintenance Planner

			1st Year	2nd Year	3rd Year	4th Year	5th Year
<b>PRESEASON CHECK</b>	1.1	Check quality of filters					
	1.2	Check fan & pump					
	1.3	Fill unit with water					
	1.4	Start unit					
	1.5	Check bleed-off system					
<b>FIRST MIDSEASON SERVICE</b>	2.1	Check and clean filters					
	2.2	Drain, clean and refill water tray					
	2.3	Check bleed-off system					
	2.4	Check strainers and filters					
	2.5	Check unit operates correctly					
<b>SECOND MIDSEASON SERVICE</b>	3.1	Check and clean filters					
	3.2	Drain, clean and refill water tray					
	3.3	Check bleed-off system					
	3.4	Check strainers and filters					
	3.5	Check unit operates correctly					
<b>END OF SEASON SERVICE AND SHUT DOWN</b>	4.1	Turn off water supply					
	4.2	Drain and clean unit					
	4.3	Check motor and pump and spray with a water displacement lubricant					

To Order Parts  
[www.bonairedurango.com](http://www.bonairedurango.com)

For Technical Advice/Warranties  
**1-800-939-2983**  
**Monday thru Friday 8:00 A.M. – 1:00 P.M. Pacific Time**





## Part List

No	Description	Part Number
1	Control Knob	6280133SP
2	Front Fascia	6280153SP
3	Ice door	6280149SP
4	Front Panel	6280142SP
5	Adaptor Float Valve	6280922SP
6	Float valve	6280919SP
7	Water Flow Control Valve (Dialflow)	6050904SP
8	Fan housing	6280151SP
9	Water Tank	6280143SP
10	Wheels	3500M 6280171SP
		4200M 6280173SP
11	Drain Cap	6280918SP
12	Filter Pad Set	3500M 6280126SP
		4200M 6280128SP
13	Rear Panel	3500M 6280141SP
		4200M 6280144SP
14	Filter Retainer Clips	6280134SP
15	Motor Mounting Brackets	6282010SP
16	Motor	6281601SP
17	Fan Retaining Clip	6280804SP
18	Fan	6280806SP
19	Capacitor 12.0 $\mu$ F / 15.0 $\mu$ F	9041888SP / 0160177SP
20	Pump Filter Basket	6050811SP
21	Pump	6280811SP



# Problem Solving

PROBLEM	PROBABLE CAUSE	REMEDY
Unit fails to start	<ul style="list-style-type: none"> <li>a Power Failure</li> <li>b Tripped Circuit Breaker</li> <li>c Blown Fuse</li> <li>d Electrical Fault</li> </ul>	<ul style="list-style-type: none"> <li>a Wait for power to be turned on.</li> <li>b Reset circuit breaker</li> <li>c Replace</li> <li>d Call Bonaire Care Line</li> </ul>
Filter Pads not wetting.	<ul style="list-style-type: none"> <li>a Pump Seized</li> <li>b Water Control Valve(Dialflo) Setting</li> </ul>	<ul style="list-style-type: none"> <li>a Extension cord dropping voltage</li> <li>b Maintenance page. See Pump section.</li> <li>c Adjust the Water control valve (Dialflo ) See page 12.</li> <li>d Call Bonaire Care Line</li> </ul>
Filter pads too wet	<ul style="list-style-type: none"> <li>c Electrical fault with pump</li> <li>d High voltage in your area</li> </ul>	
Water leaking from overflow	<ul style="list-style-type: none"> <li>a Float Valve Leaking</li> <li>b Drain from CELdek® Pads</li> </ul>	<ul style="list-style-type: none"> <li>a Check adjustment or replace float valve if necessary</li> <li>b Normal Operation – adjust float level</li> </ul>
Water Droplets in air stream	<ul style="list-style-type: none"> <li>a Loose Delivery Tube</li> <li>b Break in tubing</li> <li>c Pump appears to deliver excessive water to pads</li> </ul>	<ul style="list-style-type: none"> <li>a Check and tighten</li> <li>b Replace as necessary</li> <li>c. Check the condition of the filter pad. Wash if pad shows heavy buildup of minerals</li> </ul>
	<ul style="list-style-type: none"> <li>d Bleed nozzle is blocked</li> </ul>	<ul style="list-style-type: none"> <li>d Clean bleed nozzle</li> </ul>
Excessive humidity	<ul style="list-style-type: none"> <li>a Not enough air flow</li> <li>b Inadequate Exhaust</li> </ul>	<ul style="list-style-type: none"> <li>a Increase fan speed</li> <li>b Provide more open area to exhaust stale air by opening windows and doors in adjacent rooms.</li> </ul>
Inadequate Cooling	<ul style="list-style-type: none"> <li>a Dirty Filters</li> <li>b Dry Filters</li> </ul>	<ul style="list-style-type: none"> <li>a Clean</li> <li>b Check control set on COOL mode. Check water delivery system. Adjust if necessary.</li> </ul>
Unpleasant Odor	<ul style="list-style-type: none"> <li>a Unit located near odor source</li> <li>b Algae in water tank</li> </ul>	<ul style="list-style-type: none"> <li>a Remove source</li> <li>b Clean tank and refill with fresh water.</li> </ul>
Rapid formation of white deposits on pads	<p style="text-align: center;">High Mineral Content</p>	<p>Bleed off should be checked to see if bleed nozzle is blocked, clear if necessary and clean CELdek® pad. Increase the bleed rate – see page 14. More regular maintenance may be required.</p>

ANY FURTHER PROBLEMS PLEASE CONTACT YOUR  
**BONAIRE CUSTOMER CARE LINE ON 1-800-939-2983**



# Warranty

## Statement on Product Warranty (U.S.A.)

### 1. Warranty

Subject to the Conditions and Exclusions, Climate Technologies Pty Ltd provides the original purchaser with the following warranty:

**Climate Technologies Pty Ltd warrants this appliance for a 12 month period from the date of purchase. During this period, a defective appliance or defective parts will be repaired or replaced free of charge at the election of Climate Technologies Pty Ltd.**

### 2. Conditions and Exclusions

- a) The warranty only covers window coolers manufactured by Climate Technologies Pty Ltd and purchased in the U.S.A.
- b) The warranty does not cover installation components that may be attached to the product manufactured by Climate Technologies Pty Ltd. These may include and is not limited to items such as ducting, flues, grills, piping, etc. These items remain solely the responsibility of the installer / owner.
- c) This warranty is only valid if the appliance is installed and operated in accordance with the manufacturer's instructions and for its designed and intended purpose at the nominated phase, voltage and frequency.
- d) Product fitness for purpose and overall system design / sizing are solely the responsibility of the installer / owner. This includes but is not limited to heat load calculations, air flow, system balancing, humidity, water quality, etc.
- e) Industrial or commercial use of this product will void the warranty. The appliance is designed for domestic use only.
- f) The product must be installed by a qualified person in the manner prescribed by local and statutory regulations and to the manufacturer's specifications.
- g) Warranty will only be given where proof of purchase is provided by the original purchaser and Climate Technologies Pty Ltd is satisfied that the appliance is within the warranty period.
- h) Warranty will not be provided where, in Climate Technologies Pty Ltd opinion:
  - i. There is nothing wrong with the appliance.
  - ii. The defective operation of the appliance is due to failure of electricity or water supply.
  - iii. Defects are caused by neglect, incorrect application, abuse or by accidental damage of the appliance.
  - iv. An unauthorised person has attempted to repair the appliance.
  - v. The appliance has been changed or modified in any way.
  - vi. A situation arises referenced in the trouble-shooting guide.
- i) Damage caused by elements such as wind, rain, lightning, floods, etc along with power spiking and brownouts are not considered defective material or workmanship and as such are not covered by our warranty.
- j) If there is no certificate of compliance for plumbing or electrical work, Climate Technologies Pty Ltd reserves the right to refuse warranty on non-compliant installations.
- k) No responsibility will be accepted for outside elements such as pests, animals, pets and vermin that may cause damage to the unit.
- l) Harsh environmental situations such as salt air that may cause damage are not covered.



# Warranty

- m) Responsibility or liability is not accepted for damage to contents, carpet, walls, ceilings, foundations or any other consequential loss or damage of whatever nature either direct or indirect resulting from installation, operation or misuse of the appliance.
- n) Parts replaced under warranty are warranted for the balance of the original Warranty Period.
- o) All warranties are non-transferable.
- p) The benefits conferred by this warranty are in addition to warranties and other rights in respect of the appliance, which the consumer has under State and Federal laws. This warranty must be read subject to that legislation and nothing in this warranty has the effect of excluding, restricting or modifying those rights.

### 3. Climate Technologies Pty Ltd

Climate Technologies Pty Ltd is a company incorporated in Australia (A.C.N. number 001 418 042). Reference to Climate Technologies Pty Ltd includes its authorized distributors.

#### Warranty for Replacement Parts.

Parts replace under warranty are warranted for the balance of the Window Cooler’s original warranty period.

#### Proof of Purchase

Please attach your proof of purchase here. Your receipt is your warranty and will be required to validate any warranty.

#### Dealer / Product Information

Dealer/Retailer:	
Address:	
Phone Number:	
Unit Model Number:	
Serial No:	



**Notes**

**Notes**



**Notes**





*“Excelling today for a better tomorrow”*

Manufactured by  
**Climate Technologies Pty Ltd**  
ABN 13 001 418 042  
26 Nylex Avenue  
Salisbury, SA 5108  
AUSTRALIA

[www.bonairedurango.com](http://www.bonairedurango.com)



## Free Manuals Download Website

<http://myh66.com>

<http://usermanuals.us>

<http://www.somanuals.com>

<http://www.4manuals.cc>

<http://www.manual-lib.com>

<http://www.404manual.com>

<http://www.luxmanual.com>

<http://aubethermostatmanual.com>

Golf course search by state

<http://golfingnear.com>

Email search by domain

<http://emailbydomain.com>

Auto manuals search

<http://auto.somanuals.com>

TV manuals search

<http://tv.somanuals.com>