

W  
D  
S  
G  
S  
R  
E  
S  
D

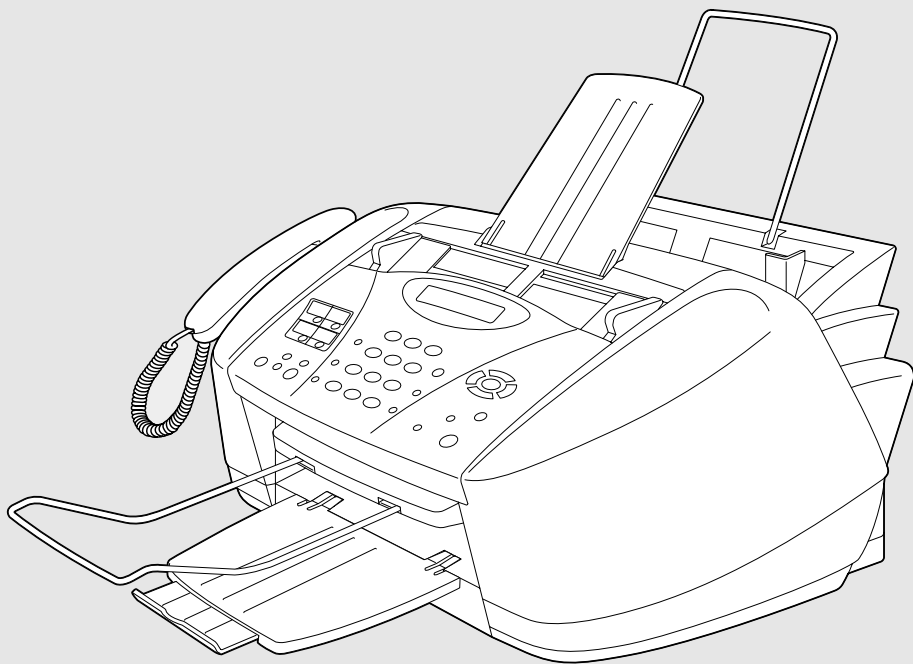

# MFC-3200C

---

brother.

## If You Need to Call Customer Service

Please complete the following information for future reference:

**Model Number:** MFC-3200C

**Serial Number:\*** \_\_\_\_\_

**Date of Purchase:** \_\_\_\_\_

**Place of Purchase:** \_\_\_\_\_

**\* The serial number is on the back of the unit. Retain this User's Guide with your sales receipt as a permanent record of your purchase, in the event of theft, fire or warranty service.**

Register your warranty on-line at

[www.registermybrother.com](http://www.registermybrother.com)

By registering your product with Brother International Corporation, you will be recorded as the original owner of the product. Your registration with Brother:

- may serve as confirmation of the purchase date of your product should you lose your receipt;
- may support an insurance claim by you in the event of product loss covered by insurance; and,
- will help us notify you of enhancements to your product and special offers.

The most convenient and efficient way to register your new product is on-line at [www.registermybrother.com](http://www.registermybrother.com)

# Brother Numbers

## IMPORTANT

For technical help you must call the country where you bought the MFC. Calls must be made *from within* that country.

## Register Your Product

By registering your product with Brother International Corporation, you will be recorded as the original owner of the product. Your registration with Brother:

- may serve as confirmation of the purchase date of your product should you lose your receipt;
- may support an insurance claim by you in the event of product loss covered by insurance; and,
- will help us notify you of enhancements to your product and special offers.

Please complete and fax the Brother Warranty Registration And Test Sheet or, for your convenience and most efficient way to register your new product, register on-line at

[www.registermybrother.com](http://www.registermybrother.com)

## Frequently Asked Questions (FAQs)

The Brother Solutions Center is our one-stop resource for all your Fax Machine/Multi-Function Center needs. You can download the latest software and utilities, read FAQs and troubleshooting tips, and go to the 'Solutions' section to learn how to get the most from your Brother product.

<http://solutions.brother.com>



You can check here for Brother driver updates.

## For Customer Service

- In USA:** 1-800-284-4329 (voice)  
1-901-379-1215 (fax)  
1-800-284-3238 (TTY service for the hearing-impaired)
- In Canada:** 1-877-BROTHER (voice)  
(514) 685-4898 (fax)  
(514) 685-6464 (voice) **In Montreal**

## Service Center Locator (USA Only)

For the location of a Brother authorized service center, call 1-800-284-4357.

## Service Center Locations (Canada Only)

For the location of a Brother authorized service center, call 1-877-BROTHER.

## Brother fax back system (USA Only)

Brother has installed an easy-to-use fax back system, so you can get instant answers to common technical questions and product information for all Brother products. This system is available 24 hours a day, 7 days a week. You can use the system and an Index of fax back subjects.

**In USA only:** 1-800-521-2846

The Brother fax back system number has been preprogrammed on One Touch key **1**.

## Ordering Accessories and Supplies

For best quality results use only genuine Brother accessories, available at most Brother retailers. If you cannot find the accessory you need and you have a Visa, MasterCard, Discover, or American Express credit card, you can order accessories directly from Brother. (In the USA, you can visit us online for a complete selection of Brother accessories and supplies available for purchase.)

**In USA:** 1-888-879-3232 (voice)  
1-800-947-1445 (fax)

<http://www.brothermall.com>

**In Canada:** 1-877-BROTHER (voice)

Description	Item
Ink Cartridge <black>	LC21BK
Ink Cartridge <cyan>(blue)	LC21C
Ink Cartridge <magenta>(red)	LC21M
Ink Cartridge <yellow>	LC21Y
Power Protector for A/C Power and Phone Line	QPD120
Telephone Line Cord	LG3077001
Telephone Handset	LE0446011
Handset Curled Cord	LE6681001
Paper Support	UU1309001
ADF Document Output Support	LE3305001
ADF Document Support	LE6396002
Output Paper Support	LE6398002
Card Stock Support	LE6486002
User's Guide	LE6891001



*Multi-Function Link® Pro Suite is NOT available on floppy disks.*

## **Notice – Disclaimer of Warranties (USA and Canada)**

BROTHER'S LICENSOR(S), AND THEIR DIRECTORS, OFFICERS, EMPLOYEES OR AGENTS (COLLECTIVELY BROTHER'S LICENSOR) MAKE NO WARRANTIES, EXPRESS OR IMPLIED, INCLUDING WITHOUT LIMITATION THE IMPLIED WARRANTIES OF MERCHANTABILITY AND FITNESS FOR A PARTICULAR PURPOSE, REGARDING THE SOFTWARE. BROTHER'S LICENSOR(S) DOES NOT WARRANT, GUARANTEE OR MAKE ANY REPRESENTATIONS REGARDING THE USE OR THE RESULTS OF THE USE OF THE SOFTWARE IN TERMS OF ITS CORRECTNESS, ACCURACY, RELIABILITY, CURRENTNESS OR OTHERWISE. THE ENTIRE RISK AS TO THE RESULTS AND PERFORMANCE OF THE SOFTWARE IS ASSUMED BY YOU. THE EXCLUSION OF IMPLIED WARRANTIES IS NOT PERMITTED BY SOME STATES IN THE USA AND SOME PROVINCES IN CANADA. THE ABOVE EXCLUSION MAY NOT APPLY TO YOU.

IN NO EVENT WILL BROTHER'S LICENSOR(S) BE LIABLE TO YOU FOR ANY CONSEQUENTIAL, INCIDENTAL OR INDIRECT DAMAGES (INCLUDING DAMAGES FOR LOSS OF BUSINESS PROFITS, BUSINESS INTERRUPTION, LOSS OF BUSINESS INFORMATION, AND THE LIKE) ARISING OUT OF THE USE OR INABILITY TO USE THE SOFTWARE EVEN IF BROTHER'S LICENSOR HAS BEEN ADVISED OF THE POSSIBILITY OF SUCH DAMAGES. BECAUSE SOME STATES IN THE USA AND SOME PROVINCES IN CANADA DO NOT ALLOW THE EXCLUSION OR LIMITATION OF LIABILITY FOR CONSEQUENTIAL OR INCIDENTAL DAMAGES, THE ABOVE LIMITATIONS MAY NOT APPLY TO YOU. IN ANY EVENT BROTHER'S LICENSOR'S LIABILITY TO YOU FOR ACTUAL DAMAGES FROM ANY CAUSE WHATSOEVER, AND REGARDLESS OF THE FORM OF THE ACTION (WHETHER IN CONTRACT, TORT (INCLUDING NEGLIGENCE), PRODUCT LIABILITY OR OTHERWISE), WILL BE LIMITED TO \$50.

## **Compilation and Publication Notice**

Under the supervision of Brother Industries Ltd., this manual has been compiled and published, covering the latest product descriptions and specifications.

The contents of this manual and the specifications of this product are subject to change without notice.

Brother reserves the right to make changes without notice in the specifications and materials contained herein and shall not be responsible for any damages (including consequential) caused by reliance on the materials presented, including but not limited to typographical and other errors relating to the publication.

# Brother® One Year Limited Warranty and Replacement Service (USA Only)

## Who is covered:

- This limited warranty (“warranty”) is given only to the original end-use/retail purchaser (referred to in this warranty as “Original Purchaser”) of the accompanying product, consumables and accessories (collectively referred to in this warranty as “this Product”).
- If you purchased a product from someone other than an authorized Brother reseller in the United States or if the product was used (including but not limited to floor models or refurbished product), prior to your purchase you are not the Original Purchaser and the product that you purchased is not covered by this warranty.

## What is covered:

- This Product includes a Machine and Consumable and Accessory Items. Consumable and Accessory Items include but are not limited to print heads, toner, drums, ink cartridges, print cartridges, refill ribbons, therma PLUS paper and thermal paper.
- Except as otherwise provided herein, Brother warrants that the Machine and the accompanying Consumable and Accessory Items will be free from defects in materials and workmanship, when used under normal conditions.
- This warranty applies only to products purchased and used in the United States. For products purchased in, but used outside, the United States, this warranty covers only warranty service within the United States (and does not include shipping outside the United States).

## What is the length of the Warranty Periods:

- Machines: one year from the original purchase date.
- Accompanying Consumable and Accessory Items: 90 days from the original purchase date or the rated life of consumable, whichever comes first.

## What is NOT covered:

This warranty does not cover:

- (1) Physical damage to this Product;
- (2) Damage caused by improper installation, improper or abnormal use, misuse, neglect or accident (including but not limited to transporting this Product without the proper preparation and/or packaging);
- (3) Damage caused by another device or software used with this Product (including but not limited to damage resulting from

- use of non Brother®-brand parts and Consumable and Accessory Items);
- (4) Consumable and Accessory Items that expired in accordance with a rated life; and,
- (5) Problems arising from other than defects in materials or workmanship.

This limited warranty is VOID if this Product has been altered or modified in any way (including but not limited to attempted warranty repair without authorization from Brother and/or alteration/removal of the serial number).

## What to do if you think your Product is eligible for warranty service:

Report your issue to either our Customer Service Hotline at 1-800-284-4329 or a Brother Authorized Service Center within the applicable warranty period. Supply Brother or the Brother Authorized Service Center with a copy of your dated bill of sale showing that this Product was purchased within the U.S. For the name of local Brother Authorized Service Center(s), call 1-800-521-2846.

## What Brother will ask you to do:

After contacting Brother or a Brother Authorized Service Center, you may be required to deliver (by hand if you prefer) or send the Product properly packaged, freight prepaid, to the Authorized Service Center together with a photocopy of your bill of sale. **You are responsible for the cost of shipping, packing product, and insurance (if you desire). You are also responsible for loss or damage to this Product in shipping.**

## What Brother will do:

If the problem reported concerning your Machine and/or accompanying Consumable and Accessory Items is covered by this warranty and if you first reported the problem to Brother or an Authorized Service Center within the applicable warranty period, Brother or its Authorized Service Center will repair or replace the Machine and/or accompanying Consumable and Accessory Items at no charge to you for parts or labor. The decision as to whether to repair or replace the Machine and/or accompanying Consumable and Accessory Items is made by Brother in its sole discretion. Brother reserves the right to supply a refurbished or remanufactured replacement Machine and/or accompanying Consumable and Accessory Items and use refurbished parts provided such replacement products conform to the manufacturer's specifications for new product/parts. The repaired or replacement

## Brother® One Year Limited Warranty and Replacement Service (USA Only)

Machine and/or accompanying Consumable and Accessory Items will be returned to you freight prepaid or made available for you to pick up at a conveniently located Authorized Service Center.

If the Machine and/or accompanying Consumable and Accessory Items are not covered by this warranty (either stage), you will be charged for shipping the Machine and/or accompanying Consumable and Accessory Items back to you.

**The foregoing are your sole (i.e., only) and exclusive remedies under this warranty.**

### **What happens when Brother elects to replace your Machine:**

When a replacement Machine is authorized by Brother, and you have delivered the Machine to an Authorized Service Center, the Authorized Service Center will provide you with a replacement Machine after receiving one from Brother. If you are dealing directly with Brother, Brother will send to you a replacement Machine with the understanding that you will, after receipt of the replacement Machine, supply the required proof of purchase information, together with the Machine that Brother agreed to replace. You are then expected to pack the Machine that Brother agreed to replace in the package from the replacement Machine and return it to Brother using the pre-paid freight bill supplied by Brother in accordance with the instructions provided by Brother. Since you will be in possession of two machines, Brother will require that you provide a valid major credit card number. Brother will issue a hold against the credit card account number that you provide until Brother receives your original Product and determines that your original Product is entitled to warranty coverage. Your credit card will be charged up to the cost of a new Product only if: (i) you do not return your original Product to Brother within five (5) business days; (ii) the problems with your original Product are not covered by the limited warranty; (iii) the proper packaging instructions are not followed and has caused damage to the product; or (iv) the warranty period on your original Product has expired or has not been sufficiently validated with a copy of the proof of purchase (bill of sale). The replacement Machine you receive (even if refurbished or remanufactured) will be covered by the balance of the limited warranty period remaining on the original Product, plus an additional thirty (30) days. You will keep the

replacement Machine that is sent to you and your original Machine shall become the property of Brother. **Retain your original Accessory Items and a copy of the return freight bill, signed by the courier.**

### **Limitations:**

Brother is not responsible for damage to or loss of any equipment, media, programs or data related to the use of this Product. Except for that repair or replacement as described above, Brother shall not be liable for any direct, indirect, incidental or consequential damages or specific relief. Because some states do not allow the exclusion or limitation of consequential or incidental damages, the above limitation may not apply to you.

THIS WARRANTY IS GIVEN IN LIEU OF ALL OTHER WARRANTIES, WRITTEN OR ORAL, WHETHER EXPRESSED BY AFFIRMATION, PROMISE, DESCRIPTION, DRAWING, MODEL OR SAMPLE. ANY AND ALL WARRANTIES OTHER THAN THIS ONE, WHETHER EXPRESS OR IMPLIED, INCLUDING IMPLIED WARRANTIES OF MERCHANTABILITY AND FITNESS FOR A PARTICULAR PURPOSE, ARE HEREBY DISCLAIMED.

- This Limited Warranty is the only warranty that Brother is giving for this Product. It is the *final expression and the exclusive and only statement* of Brother's obligations to you. It replaces all other agreements and understandings that you may have with Brother or its representatives.
- This warranty gives you certain rights and you may also have other rights that may vary from state to state.
- This Limited Warranty (and Brother's obligation to you) may not be changed in any way unless you and Brother sign the same piece of paper in which we (1) refer to this Product and your bill of sale date, (2) describe the change to this warranty and (3) agree to make that change.

**Important:** *We recommend that you keep all original packing materials, in the event that you ship this product.*

## **BROTHER MULTIFUNCTION CENTER/FACSIMILE MACHINE LIMITED WARRANTY (Canada Only)**

Pursuant to this limited warranty of 1 year from the date of purchase for labour and parts, Brother International Corporation (Canada) Ltd. ("Brother"), or its Authorized Service Centers, will repair this MFC/Facsimile machine free of charge if defective in material or workmanship. This Limited Warranty does not include cleaning, consumables (including, without limitation, print cartridges, print head, toner and drum) or damage caused by accident, neglect, misuse or improper installation or operation, any damage caused from service, maintenance, modifications, or tampering by anyone other than a Brother Authorized Service Representative, or from the use of supplies or consumable items that are non-Brother products. Operation of the MFC/Facsimile machine in excess of the specifications or with the Serial Number or Rating Label removed shall be deemed abuse and all repairs thereafter shall be the sole liability of the end-user/purchaser. In order to obtain warranty service, the MFC/Facsimile machine must be delivered or shipped freight prepaid by the end user/purchaser to a "Brother" Authorized Service Center, together with your Proof of Purchase in the form of a Sales Receipt.

For laser products: Failure to remove the Toner Cartridge (and Toner Drum Unit on applicable models) during shipping will cause severe damage to the MFC/Facsimile and will VOID the Warranty. (Refer to your Operation Manual for proper packaging.)

For ink-jet products: Do not remove the ink cartridges during shipping. Damage to your print head resulting from packing without the ink cartridges will VOID your warranty. (Refer to your Operation Manual for proper packaging.)

**BROTHER DISCLAIMS ALL OTHER WARRANTIES EXPRESSED OR IMPLIED INCLUDING, WITHOUT LIMITATION, ANY IMPLIED WARRANTIES OF MERCHANTABILITY OR FITNESS FOR A PARTICULAR PURPOSE, EXCEPT TO THE EXTENT THAT ANY WARRANTIES IMPLIED BY LAW CANNOT BE VALIDLY WAIVED.**

No oral or written information, advice or representation provided by Brother, its Authorized Service Centers, Distributors, Dealers, Agents or employees, shall create another warranty or modify this warranty. This warranty states Brother's entire liability and your exclusive remedy against Brother for any failure of the MFC/Facsimile machine to operate properly.

Neither Brother nor anyone else involved in the development, production, or delivery of this MFC/Facsimile machine shall be liable for any indirect, incidental, special, consequential, exemplary, or punitive damages, including lost profits, arising from the use of or inability to use the product, even if advised by the end user/purchaser of the possibility of such damages. Since some Provinces do not allow the above limitation of liability, such limitation may not apply to you.

This Limited Warranty gives you specific legal rights and you may also have other rights which vary from Province to Province.

**Warranty Service is available at Brother Authorized Service Centers throughout Canada. For Technical Support or for the name and location of your nearest Authorized Service Center call 1-877-BROTHER. Within Montreal, please call (514) 685-6464.**

**Internet support: [support@brother.ca](mailto:support@brother.ca) or browse**

**Brother's Web Site: [www.brother.com](http://www.brother.com)**

Brother International Corporation (Canada) Ltd.  
1 Rue Hôtel de Ville  
Dollard-Des-Ormeaux, QC H9B 3H6

At your side.  
**brother**®





# Quick Reference Guide

---



## Sending Black & White Faxes

---

### Automatic Transmission



- 1 Place the original face down in the ADF.
- 2 Enter the fax number using One Touch, Speed Dial, Search or the dial pad.
- 3 Press **Black Fax Start**.

### Sending a Cover Page

- 1 Place the original face down in the ADF.
- 2 Press **Menu/Set, 2, 2, 7**.
- 3 When **NEXT FAX ONLY?** appears, press **Menu/Set**.
- 4 Press  to select **ON**, and then press **Menu/Set**.
- 5 Press  to select a comment, and then press **Menu/Set**.
- 6 Enter two digits to indicate the number of pages being sent, and then press **Menu/Set**.
- 7 Press **1** to select additional settings—**OR**—Press **2** if you are ready to fax.
- 8 Enter the fax number.
- 9 Press **Black Fax Start**.

## Real Time Transmission

You can send faxes in real time.

- 1 Place the original face down in the ADF.
- 2 Press **Menu/Set, 2, 2, 5**.
- 3 Press  to select **ON**, and then press **Menu/Set**—**OR**—For the next transmission only, press  to select **NEXT FAX ONLY**, and then press **Menu/Set**.
- 4 For the next fax only, press  to select **ON**, and then press **Menu/Set**.
- 5 Press **1** to select additional settings—**OR**—Press **2** to fax.
- 6 Enter the fax number.
- 7 Press **Black Fax Start**.

## Receiving Faxes

---

### Select Receive Mode

Press **Receive Mode** to select **FAX ONLY**, **FAX/TEL**, **TAD:ANSWER MACH.** or **MANUAL**. If you select **FAX/TEL**, make sure to set Ring Delay and F/T Ring Time.

### Manual Reception

- 1 Pick up the handset.
- 2 Press **Black Fax Start** if you hear fax tones (beeps).
- 3 When the LCD shows **RECEIVING**, replace the handset.

## Storing Numbers

---

### Storing One Touch Dial Numbers

- 1 Press **Menu/Set**, **2**, **3**, **1**.
- 2 Press the One Touch key where you want to store the number.
- 3 Enter a number (up to 20 digits), and then press **Menu/Set**.
- 4 Enter a name (or leave it blank), and then press **Menu/Set**.
- 5 Press **Stop/Exit**.

### Storing Speed Dial Numbers

- 1 Press **Menu/Set**, **2**, **3**, **2**.
- 2 Enter a two-digit Speed Dial number, and then press **Menu/Set**.
- 3 Enter a number (up to 20 digits), and then press **Menu/Set**.
- 4 Enter a name (or leave it blank), and then press **Menu/Set**.
- 5 Press **Stop/Exit**.



## Telephone Operation

---

### One Touch Dialing / Speed Dialing

- 1 Pick up the handset—**OR**—Press **Hook/Hold** and listen for a dial tone.
- 2 When you hear the dial tone, press the One Touch key of the location you want to call—**OR**—Press **Search/Speed Dial**, press **#**, then press the two-digit Speed Dial number. (If you pressed **Hook/Hold** to dial, pick up the handset when the other party answers.)
- 3 To hang up, replace the handset.

## Search/Speed Dial

- 1 Press **Search/Speed Dial**, then enter the first letter of the name you're looking for.
- 2 Press  or  to search the memory.
- 3 When the name is displayed, lift the handset—**OR**—Press **Hook/Hold**.
- 4 Press **Black Fax Start** to dial. (If you pressed **Hook/Hold** to dial, pick up the handset when the other party answers.)
- 5 To hang up, replace the handset.

## Making Copies

---

### Making a Single Copy

- 1 Place the original face down in the ADF.
- 2 Press **Black Copy** or **Color Copy**.

### Making Multiple Copies

- 1 Place the original face down in the ADF.
- 2 Use the dial pad to enter the number of copies you want (up to 99).
- 3 Press **Black Copy** or **Color Copy**.

### Brother fax back system:

In USA: 1-800-521-2846

### Brother Global Web Site:

<http://www.brother.com>

### Frequently Asked Questions (FAQs) and Product Support:

<http://solutions.brother.com>

### Brother Accessories & Supplies:

In USA: 1-888-879-3232 (voice)  
1-800-947-1445 (fax)

<http://www.brothermall.com>

In Canada: 1-877-BROTHER (voice)

# Table of Contents

---

## 1

<b>Introduction.....</b>	<b>1-1</b>
Using This Manual .....	1-1
Finding Information.....	1-1
Conventions Used in this Manual.....	1-1
Product Registration.....	1-2
Fax Test Sheet and Product Registration (USA Only).....	1-2
On-Line Registration (USA and Canada).....	1-2
MFC-3200C Control Panel Overview.....	1-3
About Fax Machines .....	1-5
Custom Features .....	1-5
Do You Have Voice Mail on the Phone Line? .....	1-5
Why Should There Be Trouble? .....	1-5
How Can You Avoid Possible Problems? .....	1-5
Fax Tones and Handshake.....	1-5
ECM (Error Correction Mode).....	1-6

## 2

<b>Assembly and Connections .....</b>	<b>2-1</b>
Packing List.....	2-1
Choosing a Location.....	2-2
Assembly.....	2-3
Removing the Protective Yellow Bar.....	2-3
Setting Up the MFC.....	2-4
Loading Paper in the Paper Tray .....	2-8
Installing the Ink Cartridges .....	2-9
Important.....	2-11
Connecting the MFC .....	2-13
Connecting an External Telephone .....	2-13
Connecting an External Telephone	
Answering Device (TAD).....	2-13
Sequence .....	2-13
Connections.....	2-14
Recording Outgoing Message (OGM).....	2-15
Special Line Considerations .....	2-15
Roll Over Phone Lines.....	2-15
Two-Line Phone System.....	2-15
Converting Telephone Wall Outlets .....	2-16
Installing MFC, External Two-Line TAD and	
Two-Line Telephone .....	2-16

Multi-Line Connections (PBX) .....	2-17
If You are Installing the MFC to Work with a PBX:.....	2-17
Custom Features on Your Phone Line.....	2-18

### 3

<b>Paper.....</b>	<b>3-1</b>
About Paper.....	3-1
Handling and Using Special Paper.....	3-1
Recommended Paper for the MFC-3200C.....	3-1
Paper Capacity of Paper Tray.....	3-2
Paper Specifications for Paper Tray.....	3-2
Print Area.....	3-3

### 4

<b>On-Screen Programming.....</b>	<b>4-1</b>
User-Friendly Programming.....	4-1
Menu Selection Table.....	4-1
Alternating Displays.....	4-1
Navigation Keys.....	4-2
Key Operations Table.....	4-8

### 5

<b>Initial Setup.....</b>	<b>5-1</b>
Getting Started.....	5-1
Setting Paper Type.....	5-1
Setting Paper Size.....	5-1
Setting Date and Time.....	5-2
Setting Station ID.....	5-2
Entering Text.....	5-3
Inserting Spaces.....	5-3
Making Corrections.....	5-3
Repeating Letters.....	5-3
Special Characters and Symbols.....	5-3
Setting the Ring Volume.....	5-4
Setting the Beeper Volume.....	5-4
Setting the Speaker Volume.....	5-5
Setting the Handset Volume.....	5-5
Choosing the Handset Volume (For Volume Amplify).....	5-6
Setting Volume Amplify.....	5-6
Turning On Automatic Daylight Savings Time.....	5-7
Setting Tone/Pulse Dialing Mode.....	5-7
Memory Storage.....	5-7

**Setup Receive.....6-1**

Basic Receiving Operations .....	6-1
Choosing the Receive Mode.....	6-1
To Select or Change Your Receive Mode .....	6-2
Setting Ring Delay .....	6-2
Setting the F/T Ring Time (For FAX/TEL Mode Only).....	6-3
Easy Receive .....	6-3
Printing a Reduced Incoming Fax (Auto Reduction) .....	6-4
Advanced Receiving Operations .....	6-5
Operation from Extension Telephones .....	6-5
For FAX/TEL Mode Only .....	6-5
Using a Cordless External Handset.....	6-5
Changing the Remote Codes .....	6-5
Printing a Fax in Memory.....	6-6
Polling.....	6-6
Setting Up Polling Receive.....	6-6
Setting Up Sequential Polling Receive .....	6-7
Canceling a Scheduled Job.....	6-7

**Setup Send .....7-1**

Before You Begin.....	7-1
Using the ADF (Automatic Document Feeder).....	7-1
Sending Faxes with Multiple Settings.....	7-2
Basic Sending Operations .....	7-2
Contrast.....	7-2
Fax Resolution.....	7-3
Manual Transmission .....	7-3
Automatic Transmission.....	7-3
Color Fax Transmission .....	7-4
Manual and Automatic Fax Redial.....	7-4
Dual Access (Not Available for Color Faxes).....	7-4
Real Time Transmission.....	7-5
Checking Job Status .....	7-5
Canceling a Job in Memory.....	7-6
Advanced Sending Operations .....	7-7
Composing Electronic Cover Page.....	7-7
Composing Your Own Comments.....	7-7
Cover Page for the Next Fax Only.....	7-8
Always Send a Cover Page .....	7-8
Using a Printed Cover Page .....	7-9

Overseas Mode .....	7-9
Delayed FAX (Not Available for Color Faxes).....	7-10
Delayed Batch Transmission	
(Not Available for Color Faxes) .....	7-10
Setting Up Polled Transmit	
(Not Available for Color Faxes) .....	7-11

## 8

### **Auto Dial Numbers and Dialing Options ..... 8-1**

Storing Numbers for Easy Dialing .....	8-1
Storing One Touch Dial Numbers .....	8-1
Storing Speed Dial Numbers .....	8-2
Changing One Touch and Speed Dial Numbers.....	8-2
Setting Up Groups for Broadcasting .....	8-3
Dialing Options .....	8-4
Manual Dialing .....	8-4
Search .....	8-4
One Touch Dialing .....	8-5
Speed Dialing .....	8-5
Access Codes and Credit Card Numbers.....	8-6
Broadcasting (Not Available for Color Faxes).....	8-6
Pause .....	8-7
Hold .....	8-7
Fax Redial.....	8-7
Tone/Pulse .....	8-8

## 9

### **Telephone Services ..... 9-1**

Custom Features .....	9-1
Distinctive Ring.....	9-1
What Does Your Telephone Company's	
"Distinctive Ring" Do?.....	9-1
What Does Brother's "Distinctive Ring" Do? .....	9-1
Do You Have Voice Mail?.....	9-2
Before You Choose the Ring Pattern to Register .....	9-2
VERY IMPORTANT .....	9-3
Registering the Distinctive Ring Pattern.....	9-3
Caller ID .....	9-3
Viewing Caller ID List.....	9-4
Printing Caller ID List.....	9-4

**Remote Fax Options**

<b>(Not Available for Color Faxes).....</b>	<b>10-1</b>
Fax Forwarding/Paging .....	10-1
Programming a Fax Forwarding Number.....	10-1
Programming Your Pager Number.....	10-1
Setting Fax Storage .....	10-2
Backup Print .....	10-2
Changing Remote Retrieval Access Code .....	10-3
Remote Retrieval.....	10-3
Using Remote Retrieval Access Code.....	10-3
Remote Commands .....	10-4
Retrieving Fax Messages.....	10-5
Changing Fax Forwarding Number.....	10-5

**Printing Reports.....11-1**

MFC Settings and Activity.....	11-1
Customizing the Transmission Verification Report.....	11-1
Setting the Fax Activity Report Interval .....	11-1
Using the Reports Key.....	11-2
To Print a Report.....	11-2

**Making Copies.....12-1**

Basic Copy Operations.....	12-1
Making a Single Copy .....	12-1
Making Multiple Copies.....	12-1
Out of Memory Message .....	12-2
Temporary Copy Settings.....	12-2
Copying Using Multiple Settings .....	12-2
Using the Options Key .....	12-3
Paper Type .....	12-3
Paper Size.....	12-4
Copy Quality .....	12-4
Copy Brightness.....	12-4
Reducing and Enlarging Copies.....	12-5
Selecting Fixed Reduction Ratios:.....	12-5
Special Copy Option .....	12-6
2 in 1 .....	12-6
Changing Default Copy Settings.....	12-7
Copy Quality .....	12-8
Color Adjustment .....	12-8

Copy Contrast .....	12-8
Legal Limitations .....	12-9

## 13

### Using the MFC as a Printer ..... 13-1

Features .....	13-1
Printer Driver.....	13-1
Choosing the Right Kind of Paper .....	13-2
How to print your document .....	13-2
Simultaneous Printing/Fax .....	13-3
Printer Operation Key .....	13-3
Ink Key .....	13-3
Clearing Data from the Memory .....	13-3
Checking the Print Quality .....	13-3

## 14

### Printer Driver Settings (For Windows® Only) ..... 14-1

Using the Brother MFC-3200C Printer Driver.....	14-1
How to Access the Printer Driver Settings.....	14-1
Features in the Brother Native Driver .....	14-2
Paper Tab.....	14-2
Paper Size.....	14-2
Orientation .....	14-3
Copy/Page Order.....	14-3
Paper Thickness .....	14-4
Scaling.....	14-4
Paper Source .....	14-4
Quality/Color Tab.....	14-5
Quality.....	14-5
Media .....	14-6
Document .....	14-6
Color Matching .....	14-7
Custom Setting.....	14-7
Color/Mono.....	14-9
Bi-Directional Printing.....	14-9
Fast Draft Mode .....	14-9
Advanced Tab.....	14-9
Watermark.....	14-9
Watermark Style .....	14-10
Device Options.....	14-11
Print Date & Time.....	14-11
Support .....	14-12



Features in the Printer Uni-Driver (WHQL) (For Windows® XP).....	14-13
Layout Tab.....	14-13
*1 Orientation .....	14-13
*2 Pages Per Sheet .....	14-14
Paper/Quality Tab.....	14-14
*1 Tray Selection .....	14-15
*2 Quality Settings.....	14-15
*3 Color .....	14-15
Advanced Options .....	14-16
*1 Paper /Output .....	14-16
*2 Graphic.....	14-17
*3 Document Options .....	14-17
*4 Printer Features .....	14-18

## 15

### **Using the Windows®-Based Brother MFL-Pro Control Center (For Windows® 98/98SE/Me and 2000 Professional) .....15-1**

Brother MFL-Pro Control Center.....	15-1
AutoLoad the Brother Control Center.....	15-2
How to Turn Off AutoLoad.....	15-2
Brother Control Center Features .....	15-3
Auto Configuration.....	15-3
Scanning Operations.....	15-3
Copy Operations.....	15-4
PC Fax Operation .....	15-4
Scanner Settings for Scan, Copy and PC Fax Buttons .....	15-4
Global Settings .....	15-4
Setting Up the Scanner Configurations .....	15-5
To Access the Scanner Configurations Screen:.....	15-5
Perform an Operation from the Control Center Screen.....	15-5
Scan to File.....	15-6
Scanner Settings .....	15-6
Destination Folder .....	15-7
Scan to E-mail .....	15-7
Scanner Settings .....	15-8
E-mail Application .....	15-8
File Attachments.....	15-8
Conversion Options .....	15-9
Format .....	15-9

Show QuickSend Menu .....	15-9
QuickSend List.....	15-9
Scan to Word Processor .....	15-10
Scanner Settings .....	15-10
Word Processor .....	15-11
User Defined Button.....	15-12
Scanner Settings .....	15-12
Target Application.....	15-12
Copy .....	15-12
Scanner Settings .....	15-13
Copy Settings.....	15-13
Send a Fax .....	15-13
Scanner Settings .....	15-13
FAX Settings .....	15-14

## 16

### Using the Windows®-Based Brother SmartUI

#### Control Center (For Windows® XP)..... 16-1

Brother SmartUI Control Center .....	16-1
AutoLoad the Brother Control Center .....	16-2
How to Turn Off Auto Load.....	16-2
Brother Control Center Features .....	16-3
Auto Configuration.....	16-3
Hardware Section: Changing the Scan to	
Button Configuration .....	16-4
Scan To E-mail .....	16-4
Scan To Image.....	16-5
Scan To OCR.....	16-6
Software Section.....	16-8
Scan .....	16-8
Copy .....	16-9
Fax .....	16-9
Custom.....	16-9
Scan to File.....	16-10
Scan to E-mail .....	16-11
File Attachments.....	16-13
Scanner Settings .....	16-14
Scan to OCR (Word Processing Program).....	16-15
Scan to Graphics Application	
(example: Microsoft Paint) .....	16-17
Copy .....	16-19

Fax Setting (PC Fax using the Brother Fax Driver).....	16-21
FAX Settings .....	16-22
Custom: User Defined Buttons .....	16-23
Customizing a User Defined Button.....	16-23
1. Select the Scan Action .....	16-23
2. Select Configuration for the Scan Type.....	16-24
3. Select Scan Settings. ....	16-28

## 17

### **How to scan using Windows® .....17-1**

Scanning a Document (For Windows® 98/98SE/Me and 2000 Professional) .....	17-1
TWAIN Compliant.....	17-1
How to Access the Scanner .....	17-1
Scanning a Document into the PC.....	17-1
Scanning a whole page.....	17-2
PreScanning to crop a portion you want to scan .....	17-2
How to Use PreScan to Adjust an Image:.....	17-2
Settings in the Scanner Window.....	17-3
Resolution: .....	17-3
Scan Type: .....	17-3
Brightness: .....	17-4
Contrast: .....	17-4
Size:.....	17-4
Custom: .....	17-5
Scanning a Document (For Windows® XP only).....	17-6
How to Access the Scanner .....	17-6
Scanning a document into the PC.....	17-7
Brother Scanner Utility .....	17-8
Using the Color Scan Key .....	17-9
Scan to E-mail .....	17-9
Scan Image .....	17-9
Scan/OCR .....	17-10
Using ScanSoft™ PaperPort® 6.5 and TextBridge® OCR (For Windows® 98/98SE/Me and 2000 Professional) .....	17-11
Viewing Items in ScanSoft™ PaperPort® for Brother ....	17-12
Organizing Your Items in Folders .....	17-12
Links to Many Other Applications .....	17-13
Using ScanSoft™ TextBridge® OCR (Converting Image Text to Text You Can Edit) .....	17-13
Importing Items from Other Applications.....	17-14
Exporting Items in Other Formats .....	17-14

Exporting an Image File.....	17-14
Viewing items.....	17-16
Organizing your items in folders.....	17-17
Quick links to other applications.....	17-17
ScanSoft™ TextBridge® OCR lets you convert image text in to text you can edit.....	17-18
You can Import items from other applications.....	17-18
You can Export items in other formats.....	17-19
Exporting an image file.....	17-19

## 18

### Using Remote Setup (For Windows® Only) ..... 18-1

MFC Remote Setup.....	18-1
-----------------------	------

## 19

### Using PC-FAX (For Windows® Only) ..... 19-1

PC FAX Sending.....	19-1
Setting Up User Information.....	19-1
Setting Up Sending.....	19-2
Outside line access.....	19-2
Include header.....	19-2
Address Book file.....	19-2
User interface.....	19-3
Simple Style.....	19-3
Facsimile Style.....	19-3
Setting Up Speed Dial.....	19-4
The Address Book.....	19-5
Setting Up a Member in the Address Book.....	19-6
Setting Up a Group for Broadcasting.....	19-7
Editing Member Information.....	19-7
Deleting a Member or Group.....	19-8
Exporting the Address Book.....	19-8
Importing to the Address Book.....	19-9
Setting Up a Cover Page.....	19-10
To.....	19-11
From.....	19-11
Comment.....	19-11
Select Cover Page Form.....	19-11
Import BMP file.....	19-11
Count Cover Page.....	19-11
Sending a File as a PC-FAX Using the Facsimile Style.....	19-12

Redial .....	19-13
Sending a File as a PC-FAX Using the Simple Style.....	19-13

## 20

### **Using Automatic E-Mail Printing .....20-1**

For Windows® 98, 98SE, Me only .....	20-1
Main Features .....	20-1
To Access the On-Line Documentation.....	20-1
To Install Automatic E-mail Printing (Optional Application): .....	20-1

## 21

### **Using the Brother MFC with a New Power**

#### **Macintosh® G3, G4 or iMac™/iBook™ .....21-1**

Set Up Your USB-Equipped Apple® Macintosh® G3, G4 or iMac™ or iBook™ with Mac OS 8.5-9.2 or Mac OS X v.10.1 .....	21-1
Using Brother Printer Driver with Your Apple® Macintosh® (OS 8.5-9.2) .....	21-1
Using Brother Printer Driver with Your Apple® Macintosh® (OS X v.10.1).....	21-3
Choosing page setup options .....	21-3
Printing a document.....	21-3
Choosing printing options .....	21-4
Sending a Fax from Your Macintosh® Application (For OS 8.5-9.2).....	21-5
Setting Up Your Address Book.....	21-7
Adding a New Member.....	21-7
Adding a New Group.....	21-8
Using Brother TWAIN Scanner Driver with Your Apple® Macintosh® (For OS 8.6-9.2).....	21-9
Accessing the Scanner.....	21-10
Scanning a Document into Your Macintosh G3, G4 or iMac .....	21-11
Settings in the Scanner Window.....	21-11
Image.....	21-11
Scanning Area.....	21-12
Business Card Size.....	21-13
Miscellaneous .....	21-13
Contrast.....	21-13
Color Sync Dialog.....	21-14
Scanner Profile.....	21-15
PreScanning an Image .....	21-15

**Important Information ..... 22-1**

Standard Telephone and FCC Notices .....	22-1
Federal Communications Commission (FCC)	
Declaration of Conformity (For USA Only).....	22-2
Important.....	22-3
Industry Canada Compliance Statement	
(For Canada Only).....	22-3
International ENERGY STAR® Compliance	
Statement .....	22-3
Important Safety Instructions .....	22-4
Trademarks .....	22-5

**Troubleshooting and Routine Maintenance..... 23-1**

Troubleshooting.....	23-1
Error Messages .....	23-1
Original Jam .....	23-3
Printer Jam or Paper Jam.....	23-4
If You Are Having Difficulty with Your MFC .....	23-7
How to Improve Print Quality .....	23-10
Cleaning the Print Head.....	23-10
Print Quality Check .....	23-10
STEP A: Color Block Quality Check .....	23-10
STEP B: Alignment Check .....	23-11
Packing and Shipping the MFC.....	23-13
Routine Maintenance.....	23-16
Cleaning the Scanner .....	23-16
Cleaning the MFC Printer Platen .....	23-16
Replacing the Ink Cartridges .....	23-17

**Specifications ..... S-1**

Product Description.....	S-1
Fax .....	S-1
Printer .....	S-2
Printing .....	S-2
Controller.....	S-2
Computer Requirements .....	S-3
Print Media .....	S-3
Consumable Items .....	S-4

<b>Glossary .....</b>	<b>G-1</b>
<b>Index.....</b>	<b>I-1</b>
<b>Remote Retrieval Access Card .....</b>	<b>R-1</b>

## Using This Manual

---

Thank you for purchasing a Brother Multi-Function Center (MFC). This MFC has been designed to be simple to use, with LCD screen prompts to guide you through programming the settings. However, you can use your MFC to its fullest potential by taking a few minutes to read this manual.



Additionally, your MFC has a **Reports** key. Press **Reports** and **1** to print a list of basic operational steps.

## Finding Information

All chapter headings and subheadings are listed in the Table of Contents. You will be able to find information about a specific feature or operation by checking the Index in the back of this manual.

## Conventions Used in this Manual

Throughout this manual you'll see special symbols alerting you to important information, warnings, and actions to perform. For clarification, and to help you choose the correct key presses, we've added illustrations of some of the LCD messages.

<b>boldface</b>	Bold typeface identifies a specific key on the MFC control panel.
<i>italics</i>	Italics typeface emphasize an important point, or refer you to related topic.
bubble dot	Bubble Dot typeface identifies the messages on the LCD of the MFC.



Warnings detail precautions you must take to avoid possible personal injury.



Cautions specify procedures you must follow or avoid to prevent possible damage to the MFC.



Notes tell you the proper response for a situation that may occur.



FYI tips provide details about how the current operation interacts with other features.



Improper Setup alerts you to devices and procedures that are not compatible with the MFC.



# Product Registration

---

## **Fax Test Sheet and Product Registration (USA Only)**

After programming your Station ID, please fill in the TEST SHEET included with your MFC and then fax it to Brother's Automated Fax Response System as your first transmission. This will check that your MFC is working properly. To receive a response, you must have set up your Station ID. (See *Setting Station ID*, page 5-2.)

**In USA only:** 1-877-268-9575

When your TEST SHEET is received, a Confirmation Sheet and Product Registration form will be sent back to your machine. Please fill in the form and return it to complete your registration.

## **On-Line Registration (USA and Canada)**

- 1** Insert the MFL Pro Suite CD-ROM into your CD-ROM drive.
- 2** Click **On-Line Registration** to register your product.

# MFC-3200C Control Panel Overview

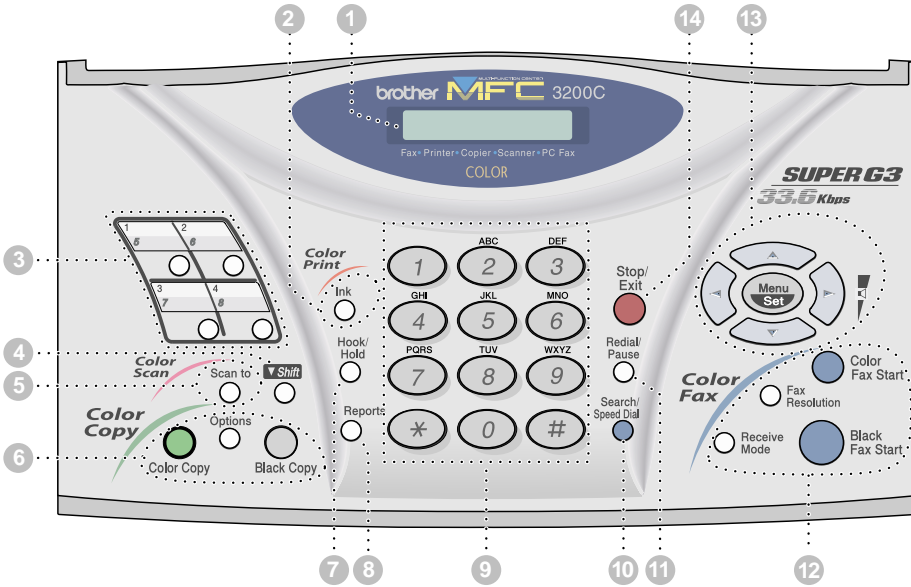

## 1 Liquid Crystal Display (LCD)

The LCD displays messages to help you set up and operate your MFC.

## 2 Ink

Cleans the ink print heads and replaces an ink cartridge.

## 3 One Touch Keys:

These 4 keys give you instant access to 8 previously stored auto dial numbers.

## 4 Shift

Accesses the second number stored on each One Touch key (5-8).

## 5 Scan to

Lets you scan the next original into your computer and select the type of destination: word processing, graphics or E-mail application.

## 6 Copy Keys: (For the Next Copy Only)

### Options

You can quickly and easily select temporary settings (for the next copy only).

### Color Copy

Makes a full-color copy.

### Black Copy

Makes a black-and-white copy.

## 7 Hook/ Hold

Lets you dial telephone and fax numbers without lifting the handset.

—OR—

Lets you place telephone calls on hold.

## 8 Reports

Accesses the Reports menu so you can select a report to print: Help List, Auto Dial, Fax Activity, Transmission Verification, User Settings.

## 9 Dial Pad

Use to dial phone and fax numbers and as a keyboard for entering information into the MFC.

The # key lets you switch the dialing type during a telephone call from PULSE to TONE.

## 10 Search/Speed Dial

Lets you look up numbers stored in the dialing memory.

Also lets you dial stored phone numbers by pressing # and a two-digit number.

## 11 Redial/Pause

Redials the last number called.

Also inserts a pause in auto dial numbers.

## 12 Fax Keys:

### Color Fax Start

Starts sending a color fax.

### Black Fax Start

Starts sending a black and white fax.

### Fax Resolution

Sets the resolution when you send a fax.

### Receive Mode

Use to select how the MFC will handle incoming calls.

## 13 Navigation Keys:

### Menu/Set

Lets you access the Menu and Programming mode, and stores your settings in the MFC.



Press to scroll forward or backward while setting a menu selection.

Also, you can use these keys to do an alphabetical search for the names of stored numbers.



### Volume

Press to scroll through the menus and options.

When using the speaker, ring or handset, you can press these keys to adjust the volume.

## 14 Stop/Exit

Stops a fax, cancels an operation, or exits from the Menu. Also, lets you clear data remaining in the printer memory.

# About Fax Machines

---

If you're a first-time MFC user, fax operation might seem a little mysterious. Soon, you'll recognize the unusual fax tones on your phone line, and be able to send and receive faxes easily.

## Custom Features

### Do You Have Voice Mail on the Phone Line?

If you have Voice Mail on the phone line on which you will install your new MFC, *there is a strong possibility that Voice Mail and the MFC will conflict with each other while receiving incoming calls.*

### Why Should There Be Trouble?

Since both MFCs and Voice Mail pick up the line at the number of rings you have set, each of them has the ability to keep the other from receiving calls. For example, if your Voice Mail is set to answer after two rings and your MFC is set to answer after four, your Voice Mail will keep your MFC from receiving faxes. If you set Voice Mail and the Brother machine to answer at the same number of rings, there is no way of knowing which one will answer first. It is important to remember that neither Voice Mail nor the MFC can pass the call back to the other after the call has been answered.

### How Can You Avoid Possible Problems?

A very good way to avoid problems like the one mentioned previously is *to get a second phone number on your present phone line.* Many people with Voice Mail opt for this choice, which is called "Distinctive Ring", and they are very satisfied with it. *For details about this type of custom service, please see Distinctive Ring, page 9-1*

Another way to avoid possible problem is to replace your Voice Mail with an answering machine. Your Brother MFC is designed to work in tandem with an answering machine or TAD (telephone answering device). (See *Connecting an External Telephone Answering Device (TAD)*, page 2-13.)

## Fax Tones and Handshake

When someone is sending a fax, the MFC sends fax calling tones (CNG tones) — soft, intermittent beeps at 4-second intervals. You'll hear them after you dial and press **Black Fax Start**; they continue for about 60 seconds after dialing. During that time, the sending machine must begin the "handshake" with the receiving machine. Each time you use automatic procedures to send a fax, you are sending CNG tones over the phone line. You'll soon learn to listen for these soft beeps each time you answer a phone on your fax line, so you can know if you are receiving a fax message.

The receiving fax responds with fax receiving tones—loud, chirping sounds. A receiving fax chirps for about 40 seconds over the phone line, and the LCD shows **RECEIVING**. If your MFC is set to the FAX mode, it will answer every call automatically with fax receiving tones. Even if the other party hangs up, your MFC continues to send the “chirps” for about 40 seconds, and the LCD continues to display **RECEIVING**. To cancel the receiving mode, press **Stop/Exit**.

When your MFC answers in FAX/TEL mode, it listens for CNG tones and then responds with receiving tones.

The fax “handshake” is the time in which the sending machine’s CNG tones and the receiving machines “chirps” overlap. This must be for at least 2 to 4 seconds, so the machines can understand how each is sending and receiving the fax. The handshake cannot begin until the call is answered, and the CNG tones only last for about 60 seconds after the number is dialed. Therefore, it’s important for the receiving machine to answer the call in as few rings as possible.



When you have an external telephone answering device (TAD) on your fax line, your TAD will determine the number of rings before the call is answered. Pay special attention to the directions chapter for connecting a TAD to your MFC in Chapter 2, *Assembly and Connections*.

## **ECM (Error Correction Mode)**

The Error Correction Mode (ECM) is a way for the MFC to check the integrity of a fax transmission while it is in progress. ECM transmissions are possible only between machines that both have the ECM feature. If they do, you may send and receive fax messages that are continuously checked for their integrity.

Sufficient memory must be available in your MFC for this feature to work.

# 2

# Assembly and Connections

## Packing List

Make sure you have the following items:

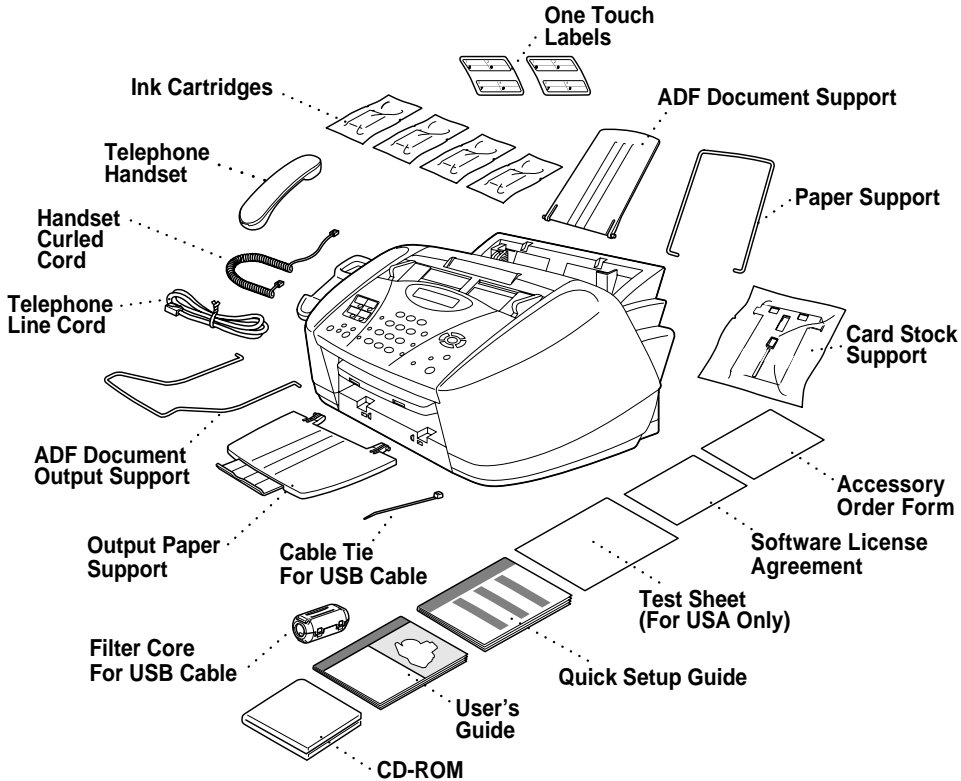

### ! Caution

Do NOT throw away the filter core and cable tie by accident. You will need them to meet FCC Emission Requirements when you connect the MFC to your computer using a USB cable (cable not included).



If an item is missing, call Brother Customer Service at 1-800-284-4329 (in USA), 1-877-BROTHER (in Canada) or (514) 685-6464 (in Montreal). See *Ordering Accessories and Supplies* on page ii for the correct item numbers.



Whenever you transport the MFC, use the packing materials that came with your MFC. If you do not pack the MFC correctly, you may void your warranty.

## Choosing a Location

---

Place your MFC on a flat, stable surface, such as a desk. Select a place that is free of vibration and shocks. Locate the MFC near a telephone jack and a standard, grounded power outlet. Choose a location where the temperature remains between 50°F and 95°F (10°–35°C).

- ⊘ Avoid placing your MFC in a high-traffic area. Do not place near heaters, air conditioners, water, chemicals, or refrigerators. Do not expose the MFC to direct sunlight, excessive heat, moisture, or dust. Do not connect your MFC to electrical outlets controlled by wall switches or automatic timers. Disruption of power can wipe out information in the MFC's memory. Do not connect your MFC to electrical outlets on the same circuit as large appliances or other equipment that might disrupt the power supply. Avoid interference sources, such as speakers or the base units of cordless phones.



### ⚠ WARNING

- Never install telephone wiring during a lightning storm.
- We recommend that this product be used with a surge protection device to protect the product against lightning storms.
- Never install a telephone jack in a wet location unless the jack is specifically designed for a wet location.
- Never touch telephone wires or terminals that are not insulated unless the telephone line has been disconnected at the network interface.
- Use caution when installing or modifying telephone lines.
- Avoid using a telephone (other than a cordless type) during an electrical storm. There may be a remote risk of electric shock from lightning.
- Do not use the telephone to report a gas leak in the vicinity of the leak.
- Install equipment with a power cord near a socket-outlet that is easily accessible.
- To reduce the risk of shock or fire, use only a No. 26 AWG or larger telecommunications line cord.

# Assembly

---

## Removing the Protective Yellow Bar

- 1 Open the control panel cover by pulling it toward you (①), and then lift the top cover toward the back (②).

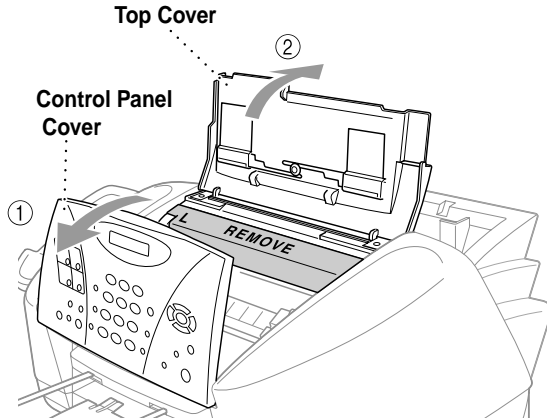

- 2 Pull the protective yellow bar out of the machine.

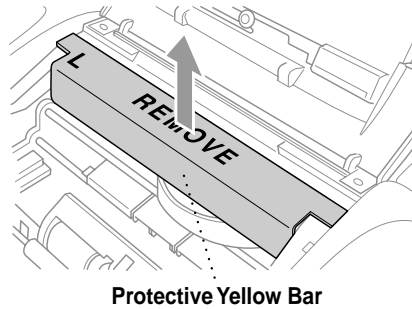

### ! Caution

Do not throw away the protective yellow bar. You will need it for future transportation.

- 3 Close the top cover, and then close the control panel cover.



## Setting Up the MFC

### 1 Connect the handset.

Connect the curled handset cord to the MFC and the other end to the handset.

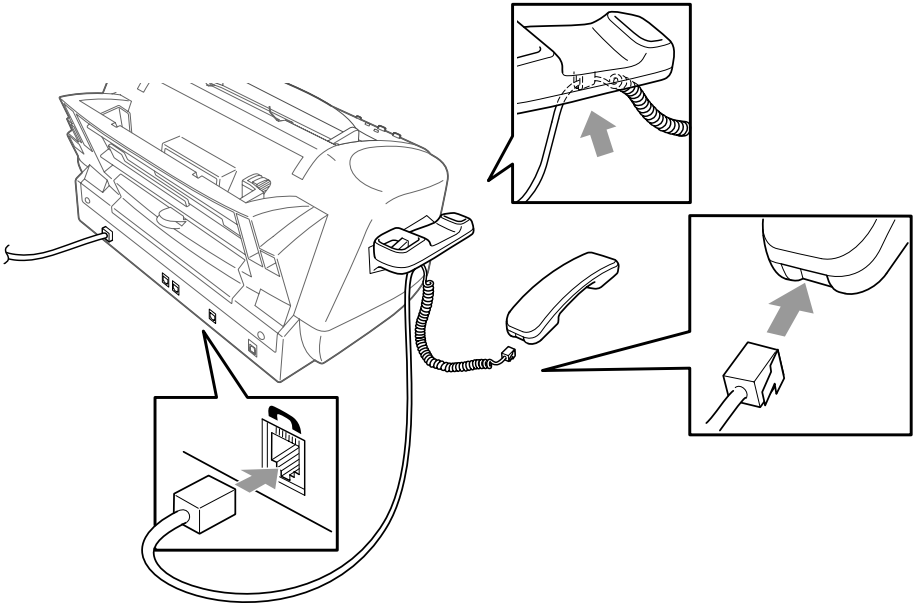

### 2 Connect the power cord.

There is no ON/OFF switch. When you plug in the power cord, the power goes on and the LCD shows:

CHECK CARTRIDGE

### WARNING

- The MFC must be grounded using a 3-prong plug.
- Since the MFC is grounded through the power outlet, you can protect yourself from potentially hazardous electrical conditions on the telephone network by keeping the power to your MFC on when you connect it to a telephone line. Similarly, you can protect yourself when you want to move your MFC by disconnecting first the telephone line and then the power cord.
- Lightning and power surges can damage this product! We recommend that you use a quality surge protection device on the AC power line as well as on the telephone line, or unplug the lines during a lightning storm.

### 3 Connect the telephone line cord.

Connect one end of the telephone line cord to the jack on the MFC and the other end to a modular wall jack.

#### ! Caution

Operating the MFC before you install the ink cartridges will permanently damage the print head.

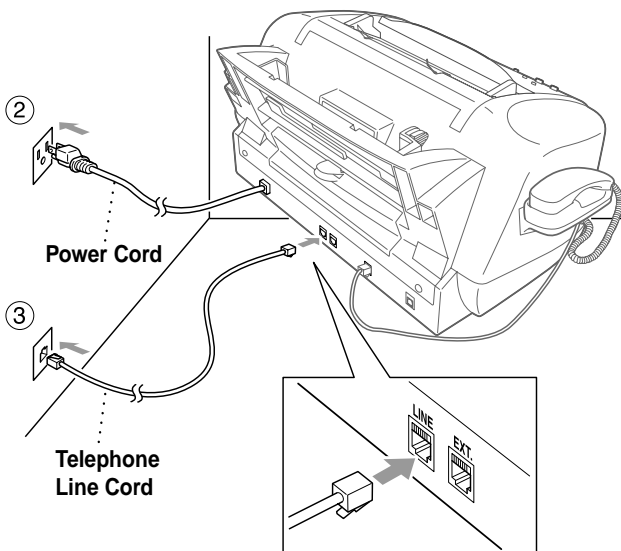

### 4 Attach the paper support to the paper tray.

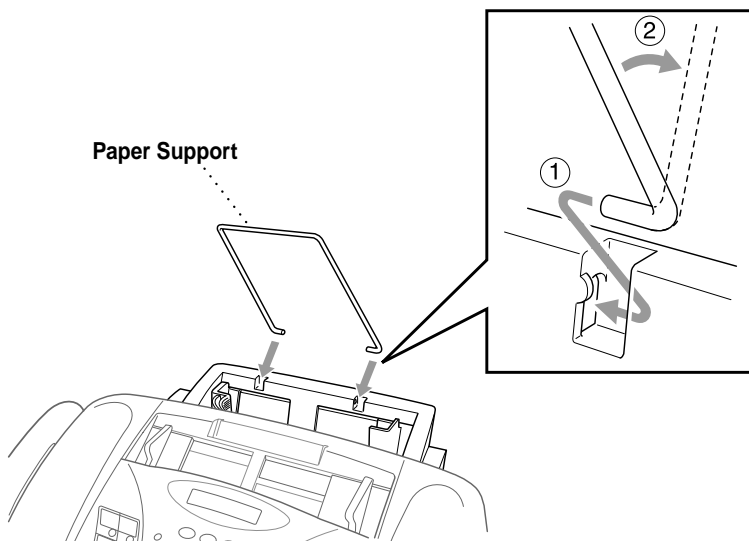

**5 Attach the ADF document support.**

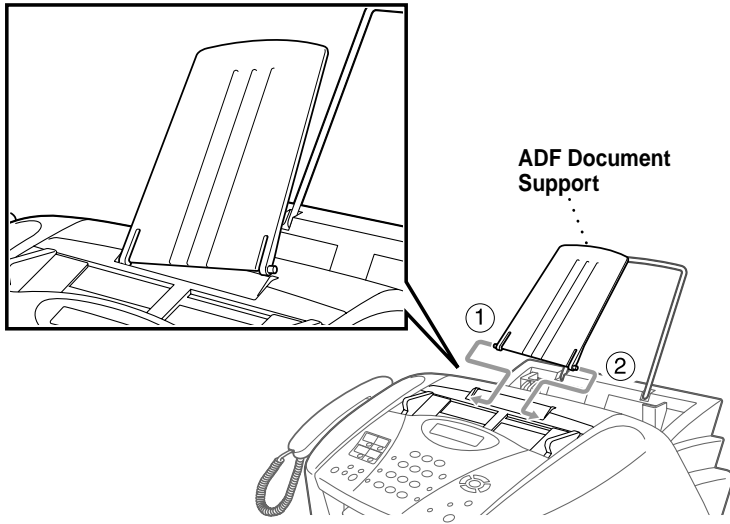

**6 Attach the output paper support, and then pull out the extension.**

**! Caution**

Please attach the output paper support to prevent paper jams and maintain print quality.

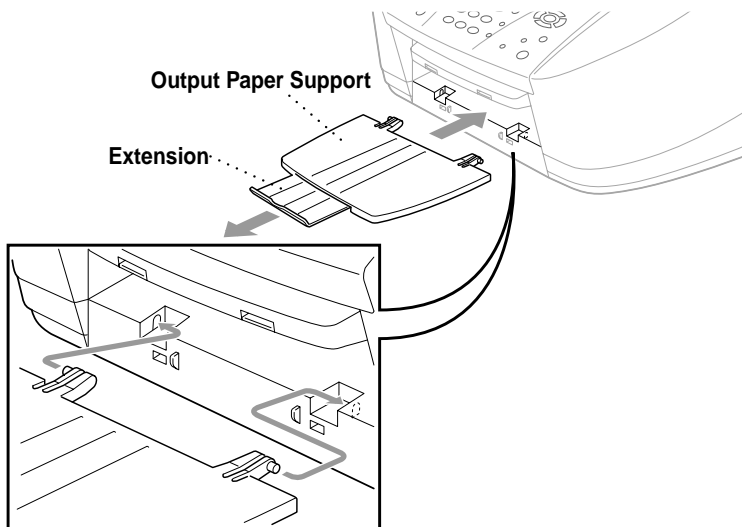

**7 Attach the ADF document output support.**

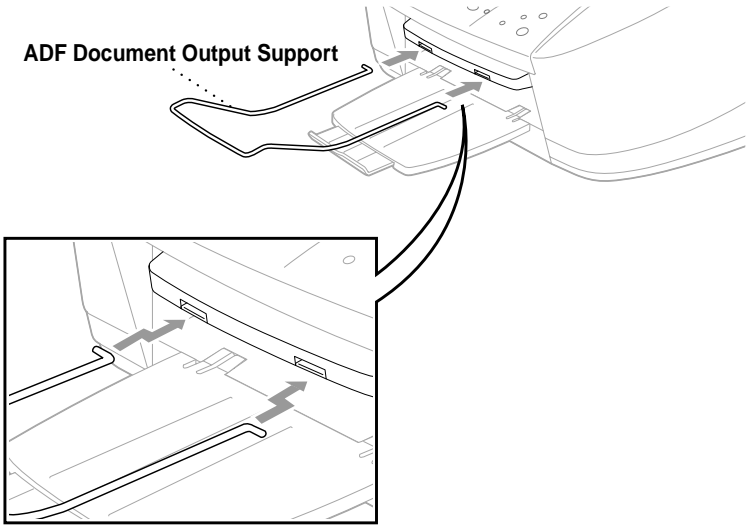

## Loading Paper in the Paper Tray

You can load up to 100 sheets of 20 lb. (75 g/m<sup>2</sup>) paper if you use the plain paper. (See *Paper Capacity of Paper Tray*, page 3-2.)

- 1 Fan the paper well. Gently insert the paper. Make sure the print side is toward you and the paper level is stacked below the paper guide line.

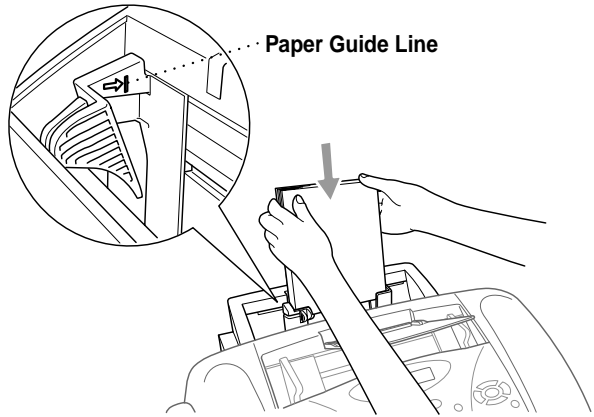

- 2 Press and slide the guide to fit the paper width.

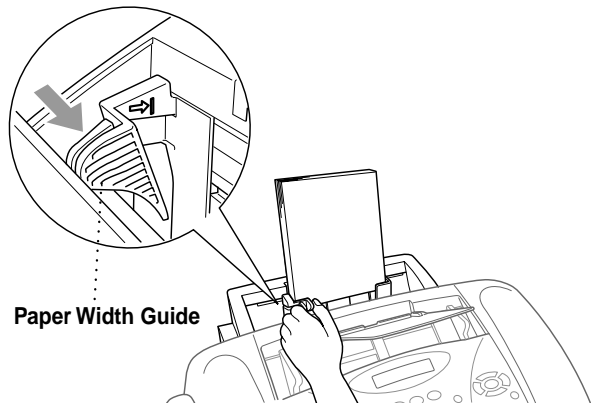

## Installing the Ink Cartridges

- 1 Check that you turned on the power (by plugging in the power cord). The LCD shows:

CHECK CARTRIDGE

- 2 Open the control panel cover by pulling it toward you (①), and then lift the top cover toward the back (②). After a few seconds, the print head will move left to its replacement position.

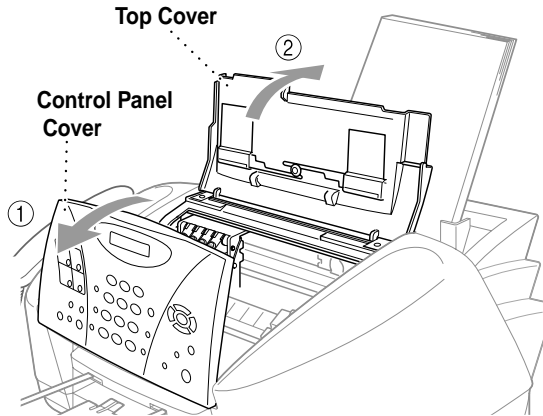

- 3 Remove the protective blue tape from the colored ink cartridge covers.

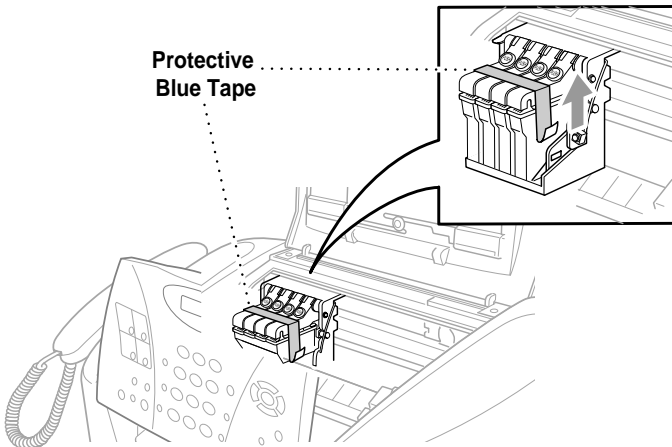

- 4 Push the four colored ink cartridge covers one at a time so they pop up. Then remove the white shipping cover by pulling it toward you and lifting it up and out.

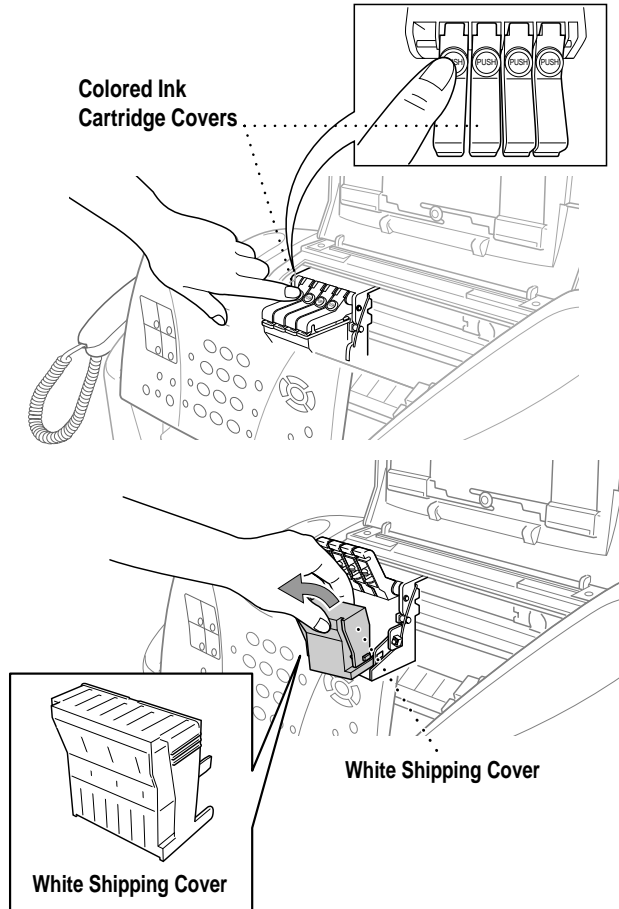

**⚠ WARNING**

If ink gets in your eyes irrigate them with water immediately; and if irritation occurs consult a doctor.

**⚠ Caution**

- The bottom of the white shipping cover is wet with ink that will cause stains, so wipe it clean before you place it down.
- Do not throw away the white shipping cover. You will need it for future transportation.

We recommend that you install the ink cartridges from left to right in this order: Black, Cyan, Yellow, Magenta.

- 5 Open the Black ink cartridge bag and take out the ink cartridge.
- 6 Carefully remove the sealing tape from the bottom of the ink cartridge. Be sure to peel the tape in the direction *away* from you.

## Important

To prevent spilling ink and staining your hands and clothing, peel the sealing tape gently and slowly. Do not touch the ink opening on the cartridge or the removed tape.

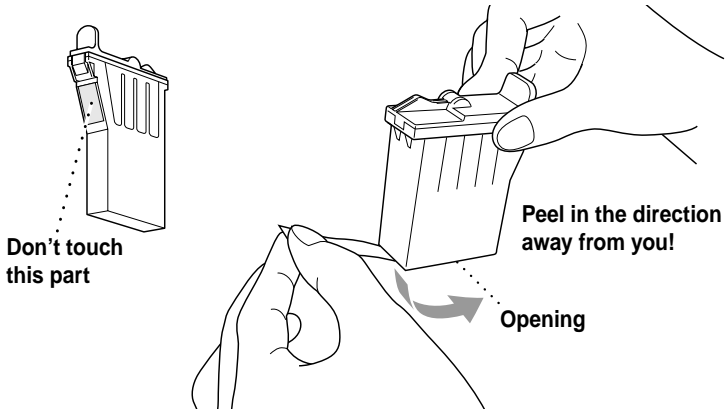

- 7 Each color has its own correct position. Match the colors of the ink cartridge covers. First, gently insert the Black ink cartridge, and then press the cover down until it clicks.

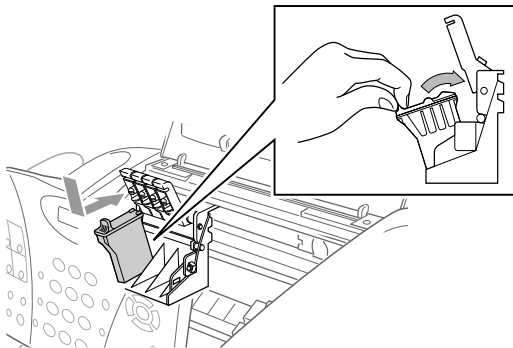

- 8 Repeat Steps 4 to 7 to install each color ink cartridge.
- 9 After installing all ink cartridges, close the top cover and control panel cover until they click into place. Your MFC will enter a "head cleaning" cycle for approximately four minutes.

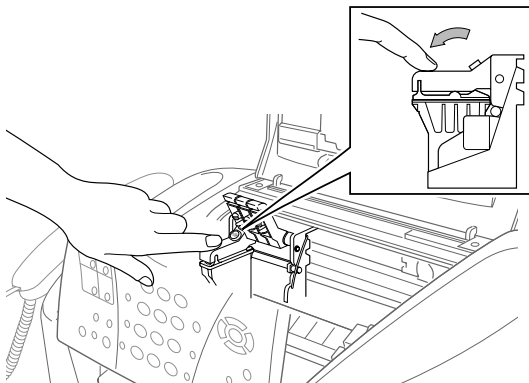



## ! Caution

Make sure the paper is loaded in the paper tray. The LCD shows **CLEANING**. After the cleaning cycle is finished, the LCD shows **PRESS FAX START**.

- 10 Press **Black Fax Start**. The MFC starts printing the Print Quality Check Sheet (only during initial ink cartridge installation).

The LCD shows:

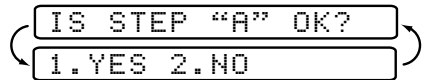

- 11 Follow the instructions printed on the sheet.

## ! Caution

- DO NOT remove ink cartridges if you do not need to replace them. If you do so, it may reduce the ink quantity and the MFC will not know the quantity of ink left in the cartridge.
- DO NOT shake the ink cartridges. If you do so, the ink may spill when you take off the sealing tape. If ink stains your body or clothing, wash with soap or detergent immediately.
- If you mix the colors by installing an ink cartridge in the wrong color position, you must clean the print head several times after correcting the cartridge installation and before you start printing.
- Once you open an ink cartridge, install it in the MFC and use it up within six months of installation. Use unopened ink cartridges by the expiration date written on the cartridge package.
- DO NOT refill the ink cartridges. Attempting to use refilled cartridges and using incompatible inks may cause damage to the print head in this machine and such damage will not be covered by warranty. Warranty coverage does not apply to problems caused by the use of 3rd party ink or 3rd party ink cartridges. Use only genuine Brother ink cartridges.



If **INK EMPTY** shows on the LCD after you install the ink cartridges, check to make sure the ink cartridges are installed correctly.

# Connecting the MFC

---

## Connecting an External Telephone

Although your MFC has a handset, you can connect a separate telephone (or telephone answering device) directly to your MFC.

Connect the modular plug on the telephone's line cord to the jack labeled **EXT.** on the back side of the MFC.

Whenever this phone (or TAD) is in use, the LCD displays **EXT. TEL IN USE**, and, if the fax handset is lifted, an alarm sounds. To disconnect the call on the external phone and switch to the fax, press **Hook/Hold**.



The external telephone can be cordless. Set the Receive Mode to **FAX/TEL**. (See *Using a Cordless External Handset*, page 6-5.)

## Connecting an External Telephone Answering Device (TAD)

### Sequence

You may choose to connect an answering device. However, when you have an **external** TAD on the same telephone line as the MFC, the TAD answers all calls. The MFC "listens" for fax calling (CNG) tones. If it hears them, the MFC takes over the call and receives the fax. If it doesn't hear CNG tones, the MFC lets the TAD continue playing your outgoing message so your caller can leave you a voice message.

The TAD must answer within five rings (the recommended setting is two rings). The MFC cannot hear CNG tones until the TAD has answered the call, and with five rings there are only 8–10 seconds of CNG tones left for the fax "handshake". Make sure you carefully follow instructions in this manual for recording your outgoing message. We do not recommend using the toll saver feature on your external answering machine if it exceeds five rings.



If you do not receive all your faxes, you must reset the setting on your external TAD to four rings or less.



The external TAD can be cordless. Set the Receive Mode to **TAD:ANSWER MACH.**



*If You Subscribe to your Telephone Company's Distinctive Ring Service:* You may connect an external TAD to a separate wall jack *only* if you subscribe to your telephone company's Distinctive Ring service, have registered the distinctive ring pattern on your MFC, use that number as a fax number, and have set your machine's Receive mode to **MANUAL**. The recommended setting is three or four rings on the external TAD when you have the telephone company's Distinctive Ring Service.



*If You Do Not Subscribe to Distinctive Ring Service:*

You *must* plug your TAD into the EXT. jack of your MFC. If your TAD is plugged into a wall jack, both your machine and the TAD will try to control the phone line. (See illustration on page 2-14.)



**Do not connect a TAD elsewhere on the same phone line** (unless you have the Distinctive Ring service).

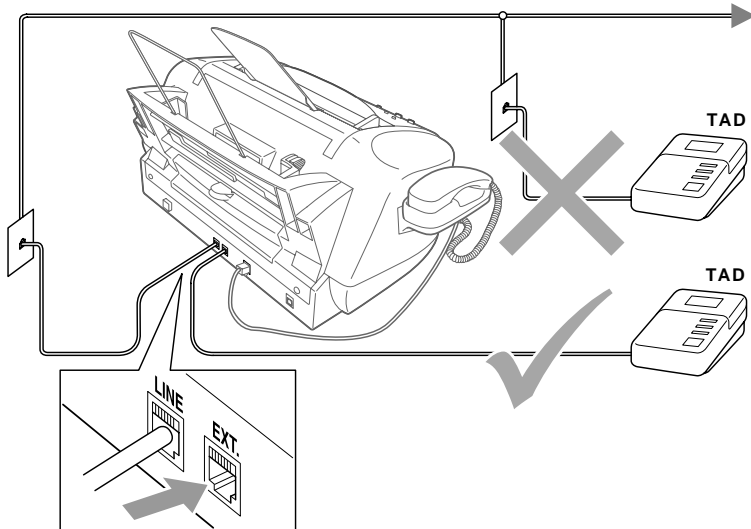

## Connections

The external TAD **must** be plugged into the back side of the MFC, in the jack labeled EXT. Your MFC cannot work properly if you plug the TAD into a wall jack (unless you are using Distinctive Ring).

- 1 Plug the telephone line cord from the wall jack into the back side of the MFC, in the jack labeled LINE.
- 2 Plug the telephone line cord from your external TAD into the back side of the MFC, in the jack labeled EXT. (Make sure this cord is connected to the TAD at the TAD's telephone line jack, and not its telephone set jack.)
- 3 Set your external TAD to four rings or less. (The MFC's Ring Delay setting does not apply.)
- 4 Record the outgoing message on your external TAD (see page 2-15).
- 5 Set the TAD to answer calls.
- 6 Set the Receive Mode to **TAD:ANSWER MACH.**  
(See *Choosing the Receive Mode*, page 6-1.)

## Recording Outgoing Message (OGM)

Timing is important in recording this message. The message sets up the ways to handle both manual and automatic fax reception.

- 1 Record 5 seconds of silence at the beginning of your message. (This allows your MFC time to listen for the fax CNG tones of automatic transmissions before they stop.)
- 2 Limit your speaking to 20 seconds.
- 3 End your 20-second message by giving your Fax Receive Code for people sending manual faxes. For example:  
“After the beep, leave a message or send a fax by pressing ✱ 51 and Start.”



We recommend beginning your OGM with an initial 5-second silence because the MFC cannot hear fax tones over a resonant or loud voice. You may try omitting this pause, but if your MFC has trouble receiving, then you must rerecord the OGM to include it.

## Special Line Considerations

### Roll Over Phone Lines

A roll over phone system is a group of two or more separate telephone lines that pass incoming calls each other if they are busy. The calls are usually passed down or “rolled over” to the next available phone line in a preset order.

Your MFC can work in a roll over system as long as it is the last number in the sequence, so the call cannot roll away. Do not put the MFC on any of the other numbers; when the other lines are busy and a second fax call would be received, the fax call is transferred to a line that does not have a fax machine. **Your MFC will work best on a dedicated line.**

### Two-Line Phone System

A two-line phone system is nothing more than two separate phone numbers on the same wall outlet. The two phone numbers can be on separate jacks (RJ11) or combined into one jack (RJ14). Your MFC must be plugged into an RJ11 jack. RJ11 and RJ14 jacks may be equal in size and appearance and both may contain four wires (black, red, green, yellow). To test the type of jack, plug in a two-line phone and see if it can access both lines. If it can, you must separate the line for your MFC. (See *Easy Receive*, page 6-3.)

## Converting Telephone Wall Outlets

There are three ways to convert to an RJ11 jack. The first two ways may require assistance from the telephone company. You can change the wall outlets from one RJ14 jack to two RJ11 jacks. Or, you can have an RJ11 wall outlet installed and slave or jump one of the phone numbers to it.

The third way is the easiest: Buy a triplex adapter. You can plug a triplex adapter into an RJ14 outlet. It separates the wires into two separate RJ11 jacks (Line 1, Line 2) and a third RJ14 jack (Lines 1 and 2). If your MFC is on Line 1, plug the MFC into L1 of the triplex adapter. If your MFC is on Line 2, plug it into L2 of the triplex adapter.

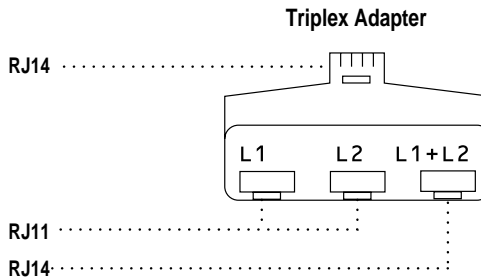

## Installing MFC, External Two-Line TAD and Two-Line Telephone

When you are installing an **external** two-line telephone answering device (TAD) and a two-line telephone, your MFC must be isolated on one line at both the wall jack and at the TAD. *The most common connection is to put the MFC on Line 2.* The two-line TAD must have two telephone jacks: one labeled L1 or L1/L2, and the other labeled L2, which is explained in the following Steps. You will need at least three telephone line cords, the one that came with your MFC and two for your external two-line TAD. You will need a fourth line cord if you add a two-line telephone.

- 1 Place the two-line TAD and the two-line telephone next to your MFC.
- 2 Plug one end of the telephone line cord for your MFC into the L2 jack of the triplex adapter. Plug the other end into the LINE jack on the left side of the MFC.
- 3 Plug one end of the first telephone line cord for your TAD into the L1 jack of the triplex adapter. Plug the other end into the L1 or L1/L2 jack of the two-line TAD.

- 4 Plug one end of the second telephone line cord for your TAD into the L2 jack of the two-line TAD. Plug the other end into the EXT. jack on the left side of the MFC.

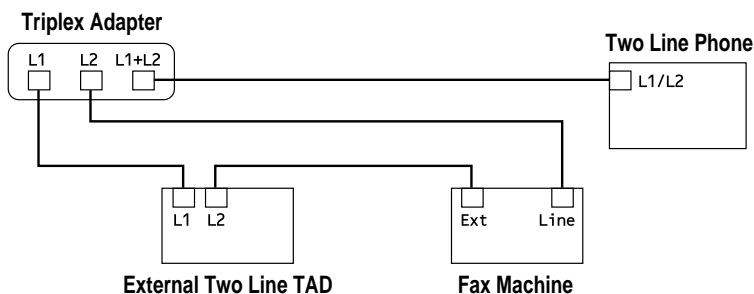

You can keep two-line telephones on other wall outlets as always. There are two ways to add a two-line telephone to the MFC's wall outlet. You can plug the telephone line cord from the two-line telephone into the L1+L2 jack of the triplex adapter. Or, you can plug the two-line telephone into the TEL jack of the two-line TAD.

## Multi-Line Connections (PBX)

Most offices use a central telephone system. While it is often relatively simple to connect the machine to a key system or a PBX (Private Branch Exchange), we suggest that you contact the company that installed your telephone system and ask them to connect the MFC for you. It is advisable to have a separate line for the MFC. You can then leave the MFC in **FAX ONLY** mode to receive faxes any time of day or night.

If the MFC is to be connected to a multi-line system, ask your installer to connect the unit to the last line on the system. This prevents the unit from being activated each time a telephone call is received.

- ⊘ As with all fax units, this machine must be connected to a two wire system. If your line has more than two wires, proper connection of the MFC cannot be made.

### If You are Installing the MFC to Work with a PBX:

- 1 It is not guaranteed that the unit will operate correctly under all circumstances with a PBX. Any cases of difficulty should be reported first to the company that handles your PBX.
- 2 If all incoming calls will be answered by a switchboard operator, it is recommended that the Receive Mode be set to **MANUAL**. All incoming calls should initially be regarded as telephone calls.
- 3 The MFC may be used with either pulse or tone dialing telephone service.

## **Custom Features on Your Phone Line**

If you have Voice Mail, Call Waiting, Call Waiting/Caller ID, RingMaster, an answering service, an alarm system or other custom feature on one phone line, it may create a problem with the operation of your MFC. (See *Custom Features on a Single Line*, page 23-8.)

# 3 Paper

## About Paper

---

The quality of your document can be affected by the kind of paper you use in the MFC. You can use plain paper, inkjet paper (coated paper), glossy paper, transparencies and envelopes. We recommend testing various papers before purchasing large quantities. For best results, use the recommended paper.

To ensure the best print quality for the settings you've chosen, always set the Paper Type to match the type of paper you load.



When using inkjet paper, glossy paper or transparencies, avoid stacking by removing each page after copying or receiving faxes.

## Handling and Using Special Paper

- Store paper in the original bag, and keep it sealed. Keep the paper flat and away from moisture, direct sunlight and heat.
- The coated side of glossy paper is shiny. Do not touch the shiny (coated) side. Load glossy paper with the shiny side facing up toward you.
- Do not touch either side of transparencies, because they absorb water and perspiration easily and may cause decreased output quality. Transparencies designed for laser printers/copiers may stain your next document. Use only recommended transparencies.

## Recommended Paper for the MFC-3200C

Plain Paper:	Xerox 4200
Inkjet Paper:	KODAK® Premium Inkjet Paper (Matte)
Glossy Paper:	JETPRINT PHOTO® Graphic image paper — Gloss Finish
Transparencies:	3M Transparency Film (CG3410)



The output quality depends on the paper type and paper brand. Visit us at <http://solutions.brother.com> and check the latest recommendations for paper that can be used with the MFC-3200C.



## Paper Capacity of Paper Tray

Paper Type	Paper Size	Capacity
Plain Paper (Cut Sheet)	Letter, Executive	100 Sheets of 20 lb. (75 g/m <sup>2</sup> )
	Legal	100 Sheets of 20 lb. (75 g/m <sup>2</sup> )
Inkjet Paper	Letter	20 Sheets
Glossy Paper*	Letter	20
Transparencies	Letter	10
Envelopes*	DL, COM-10, C5, Monarch	10
Postcard*	4" × 6"	30
Index Card*	5" × 8"	30

\*If you want to load thick paper such as postcards, index cards, envelopes and glossy paper in the paper tray, you must first install the Card Stock Support in the paper tray.

## Paper Specifications for Paper Tray

Cut Sheet Paper Weight	Plain Paper: 17 to 32 lb. (64 to 120 g/m <sup>2</sup> ) Inkjet Paper: Up to 32 lb. (120 g/m <sup>2</sup> ) Glossy Paper: Up to 40 lb. (150 g/m <sup>2</sup> ) Postcard: Up to 45 lb. (170 g/m <sup>2</sup> ) Index card: Up to 32 lb. (120 g/m <sup>2</sup> )
Thickness	Plain Paper: 0.003 to 0.006 inches (0.08 to 0.15 mm) Inkjet Paper: Up to 0.006 inches (0.15 mm) Glossy Paper: Up to 0.007 inches (0.18 mm) Envelopes: Up to 0.02 inches (0.52 mm) Postcard: Up to 0.009 inches (0.23 mm) Index card: Up to 0.006 inches (0.15 mm)
Paper Tray	Up to 0.39 inches (10 mm) Approximately 100 sheets of 20 lb. (75 g/m <sup>2</sup> )
Output Stacker	Approximately 50 sheets of 20 lb. (75 g/m <sup>2</sup> ) (Transparencies and glossy paper must be picked up from the output paper support one page at a time.)

# Print Area

The print area depends on the settings in the application you are using. The figures below show the unprintable areas on cut sheet paper and envelopes.

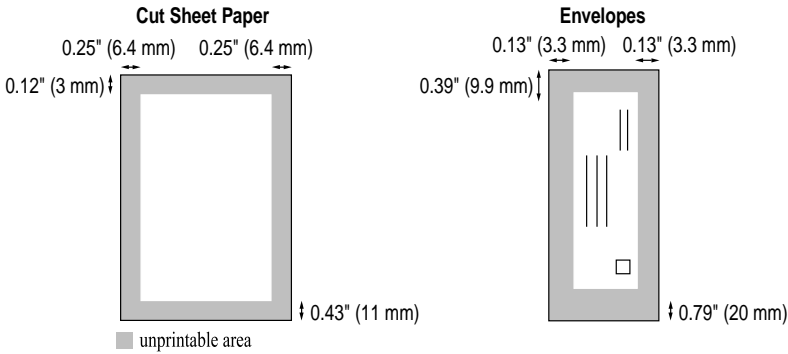

(inch)

Paper Type	Paper Size		①	②	③	④
Cut Sheet	Letter, Legal	Fax	0.12	0.43	0.25	0.25
		Mono Copy				
		Color Copy				
		Printer				
	Executive	Printer	0.12	0.43	0.13	0.13
Envelopes		Printer	0.39	0.79	0.13	0.13



Printer depends on the Printer driver.

The above figures are approximate and the print area may vary depending on the kind of paper you are using.



Do not use the following types of paper and envelopes:

- Damaged, curled, wrinkled, or irregularly shaped paper and envelopes
- Extremely shiny or highly textured paper and envelopes
- Envelopes with clasps
- Envelopes of baggy construction
- Envelopes not sharply creased
- Embossed envelopes
- Paper and envelopes already printed with a laser printer
- Envelopes preprinted on the inside
- Paper and envelopes that cannot be arranged uniformly when stacked

# 4

# On-Screen Programming

## User-Friendly Programming

We have designed your MFC with on-screen programming using navigation keys. User-friendly programming helps you take full advantage of all the menu selections your MFC has to offer.

Since your programming is done on the LCD, we created step-by-step on-screen prompts to help you program your MFC. All you need to do is follow the prompts as they guide you through the menu selections and programming options. Additionally, you can program settings more quickly by pressing **Menu/Set** and the menu number using the dial pad.

### Menu Selection Table

You can probably perform most of these programming operations without the User's Guide. To help you understand the menu selections, and options that are found in the MFC programs, use the Menu Selection Table on page 4-3.



You can program your MFC by pressing **Menu/Set** followed by the menu numbers. For example: to set **FAX RESOLUTION** to **FINE**,

press **Menu/Set**, **2**, **2**, **2** and  to select **FINE**, and then press **Menu/Set**.

### Alternating Displays

Sometimes, the LCD alternates between the active setting, and a help message giving brief instructions about how to proceed. The LCD message you'll probably see most often is shown below. When you place an original in the ADF, it appears to tell you that you can dial a number to send a fax or you can make a copy.

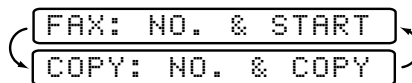

# Navigation Keys

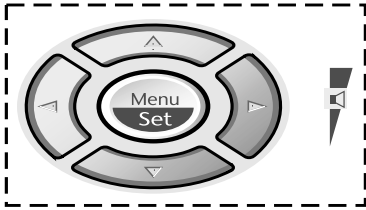

- \* Access the Menu
- \* Go to next menu level
- \* Accept an option



- \* Scroll through the current menu level



- \* Back to previous menu level



- \* Forward to next menu level



- \* Exit the Menu

You can access the menu mode by pressing **Menu/Set**. When you enter the Menu, the LCD scrolls;

Then press **1** for General Setup Menu—**OR**—

Press **2** for Fax Menu—**OR**—

Press **3** for Copy Menu—**OR**—

Press **4** for Test Print

SELECT ↑ ↓ & SET

1. GENERAL SETUP

2. FAX

3. COPY

4. TEST PRINT

—**OR**—

You can scroll more quickly through the each menu level by pressing , and then set an option by pressing **Menu/Set** when that option appears on the LCD.

Then the LCD shows next menu level. Press  to scroll to your next menu selection, and then press **Menu/Set**.

When you finish setting an option, the LCD shows **ACCEPTED**.



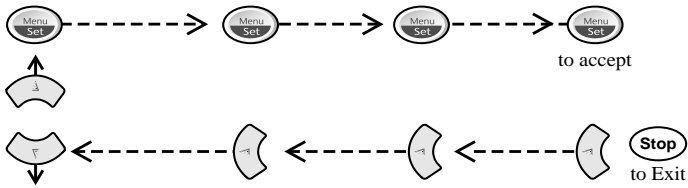

Use  to scroll backward if you passed your choices or to save keystrokes.

To access the menu, press  **Menu/Set**.



Main Menu	Submenu	Menu Selections	Options	Descriptions	Page
1. GENERAL SETUP	1. PAPER TYPE	—	PLAIN INKJET GLOSSY (4-COLOR/3-COLOR) TRANSPARENCY	Identifies the type of paper in the paper tray.	5-1
	2. PAPER SIZE	—	LETTER LEGAL A4	Selects the size of paper.	5-1
	3. DATE/TIME	—	—	Enter date and time for the LCD display and heading on fax transmissions.	5-2
	4. STATION ID	—	—	Program your name and fax number to appear on each transmitted page.	5-2
	5. VOLUME	1. RING	HIGH <b>LOW</b> OFF	Adjusts ring volume.	5-4
	2. BEEPER	HIGH <b>LOW</b> OFF	Adjusts volume level of beeper.	5-4	
	3. SPEAKER	HIGH MED <b>LOW</b> OFF	Adjusts speaker volume.	5-5	
	4. HANDSET	HIGH <b>LOW</b>	Adjusts handset volume.	5-5	
	5. VOLUME AMPLIFY	ON (PERMANENT/ TEMPORARY) <b>OFF</b>	For the hearing-impaired, you can set the volume to the VOL AMPLIFY:ON setting on a permanent or temporary basis.	5-6	

 The factory setting (option) is shown in bold.

To access the menu, press  **Menu/Set**.

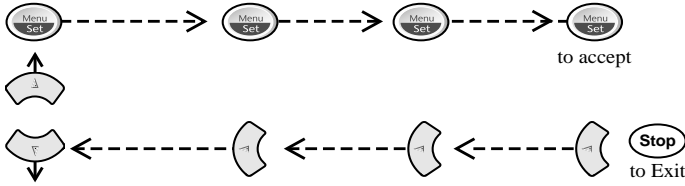







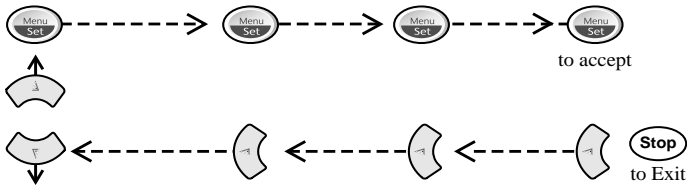















Main Menu	Submenu	Menu Selections	Options	Descriptions	Page	
1. GENERAL SETUP (Continued)	6. AUTO DAYLIGHT	—	ON OFF	↑ ↓	Changes for Daylight Savings Time automatically.	5-7
	7. TONE/PULSE	—	TONE PULSE	↑ ↓	Selects dialing mode	5-7
	8. LOCAL LANGUAGE (Canada Only)	—	ENGLISH FRENCH	↑ ↓	Allows you to change the LCD Language to French.	See French Manual
2. FAX	1. SETUP RECEIVE	1. RING DELAY	<b>04</b> 03 02 01 00	↑ ↓	Sets number of rings before MFC answers in FAX ONLY or FAX/TEL mode.	6-2
		2. FT RING TIME	70 40 30 20	↑ ↓	Sets the length of time for “double-ring” in FAX/TEL mode.	6-3
		3. EASY RECEIVE	ON SEMI OFF	↑ ↓	Receive fax messages without pressing the Start key.	6-3
		4. REMOTE CODE	ON (* 51, #51) OFF	↑ ↓	Activate or deactivate the MFC from a remote location. You can also personalize these codes.	6-5
		5. AUTO REDUCTION	ON OFF	↑ ↓	Reduces the size of incoming fax images to fit on your paper.	6-4
		6. POLLING RX	ON OFF	↑ ↓	Sets up your fax machine to poll another MFC.	6-6

 The factory setting (option) is shown in bold.

To access the menu, press  **Menu/Set**.



Main Menu	Submenu	Menu Selections	Options	Descriptions	Page
2. FAX (Continued)	2. SETUP SEND	1. CONTRAST 	<b>AUTO</b>  S.LIGHT  S.DARK 	Changes the lightness or darkness of a fax you are sending.	7-2
		2. FAX RESOLUTION	<b>STANDARD</b>  FINE  S. FINE  PHOTO 	Changes the default setting of fax resolution.	7-3
		3. DELAYED FAX	—	Sends documents later.	7-10
		4. BATCH TX	ON  OFF 	Sends all delayed faxes that are to the same fax number and at the same time as one transmission.	7-10
		5. REAL TIME TX  	<b>OFF</b>  ON  NEXT FAX ONLY 	You can send a fax without using memory.	7-5
		6. POLLED TX	ON  OFF 	Sets up your MFC with a document to be retrieved by another fax machine.	7-11
		7. COVERPG SETUP	NEXT FAX ONLY  <b>OFF</b>  PRINT SAMPLE 	Automatically sends a cover page you program.	7-8
		8. COVERPAGE MSG	—	Programs customized message for fax cover page.	7-7
		9. OVERSEAS MODE	ON  <b>OFF</b> 	Adjust for sometimes difficult overseas transmissions.	7-9

 The factory setting (option) is shown in bold.

To access the menu, press  **Menu/Set**.

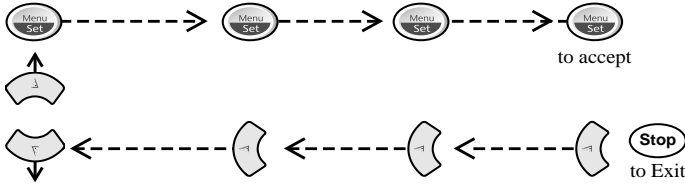

Main Menu	Submenu	Menu Selections	Options	Descriptions	Page	
2. FAX (Continued)	3. SET AUTO DIAL	1. ONE-TOUCH DIAL	—	Store One-Touch Dial so you can dial by pressing only one key.	8-1	
		2. SPEED-DIAL	—	Store Speed Dial numbers so you can dial by pressing only four keys.	8-2	
		3. SETUP GROUPS	—	Sets up a Group number for Broadcasting.	8-3	
	4. SETUP REPORTS	1. TRANSMISSION	ON ON+IMAGE	↑	Initial setup for Transmission Verification Report and Fax Activity Report.	11-1
			OFF OFF+IMAGE	↓		
	5. REMOTE FAX OPT	2. ACT. INTERVAL	OFF	↑	Sets MFC to forward fax messages— <b>OR</b> —to call your pager.	10-1
			7/4/2 Days 24/12/6 Hours	↓		
	5. REMOTE FAX OPT	1. FAX FWD/PAGING	OFF	↑	Stores incoming faxes in memory for Remote Retrieval.	10-2
			FAX FORWARD	↓		
			PAGING	↑		
			ON	↓		
	5. REMOTE FAX OPT	2. FAX STORAGE	ON	↑	Personalizes code for retrieving faxes.	10-3
OFF			↓			
5. REMOTE FAX OPT	3. REMOTE ACCESS	159 *	—	Prints incoming faxes stored in the memory.	6-6	
		—	—			

 The factory setting (option) is shown in bold.



To access the menu, press  **Menu/Set**.

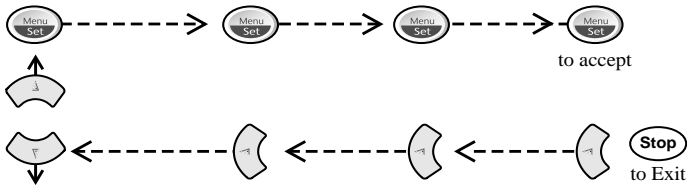

Main Menu	Submenu	Menu Selections	Options	Descriptions	Page	
2. FAX (Continued)	6. REMAINING JOBS	—	—	Check which jobs are in memory or cancel a Delayed Fax or Polling job.	6-7, 7-6	
	0. TEL SERVICE	1. DISTINCTIVE	ON  OFF  SET	↑  ↓  ↑	Uses the phone company Distinctive Ring subscriber service to register the ring pattern with the MFC.	9-3
		2. CALLER ID	DISPLAY #  PRINT REPORT	↑  ↓	View or print a list of the last 30 Caller IDs stored in memory.	9-4
3. COPY	1. QUALITY	—	NORMAL  FAST  BEST	↑  ↓  ↑	Select copy quality.	12-8
	2. COLOR ADJUST	1. RED	R: - ■■■■ + R: - ■■■□ + <b>R: - ■■■□ +</b> R: - ■■■□ + R: - ■■■□ +	↑  ↓  ↑	Adjust the amount of Red in copies.	12-8
		2. GREEN	G: - ■■■■ + G: - ■■■□ + <b>G: - ■■■□ +</b> G: - ■■■□ + G: - ■■■□ +	↑  ↓  ↑	Adjust the amount of Green in copies.	12-8
		3. BLUE	B: - ■■■■ + B: - ■■■□ + <b>B: - ■■■□ +</b> B: - ■■■□ + B: - ■■■□ +	↑  ↓  ↑	Adjust the amount of Blue in copies.	12-8
	3. CONTRAST	—	- ■■■■ + - ■■■□ + <b>- ■■■□ +</b> - ■■■□ + - ■■■□ +	↑  ↓	Adjust the contrast.	12-8
4. TEST PRINT	—	—	—	You can print a test sample page to check print quality and adjust the Vertical Alignment.	23-10	

 The factory setting (option) is shown in bold.

# Key Operations Table

You can use the temporary keys on the control panel to conveniently choose temporary copy and fax settings. The Key Operations Table below shows the options they provide.

Press the temporary key repeatedly until you see the option you want; some keys require pressing **Menu/Set** to select it. For the **Options** key, press  to scroll through the next level of options, and then select the one you want by pressing **Menu/Set** again.

Keys	Options		Descriptions	Page
<b>Options</b>	OPT:#OF COPIES 01	NO.OF COPIES:01	Enter the number of copies.	12-3
	OPT:PAPER TYPE	<b>PLAIN</b> /INK JET/ GLOSSY(4-COLOR or 3-COLOR)/ TRANSPARENCY	Identify the type of paper in the paper tray.	12-3
	OPT:PAPER SIZE	<b>LETTER</b> /LEGAL/A4/ POST CARD: 4"X6"	Specify the size of paper.	12-4
	OPT:QUALITY	<b>NORMAL</b> /BEST/FAST	Select the Quality.	12-4
	OPT:BRIGHTNESS	- ■■■□□ +	Select the degree of Brightness.	12-4
	OPT:ELG/RDC	50%, 78% LGL>LTR, 94% A4>LTR, <b>100%</b> , 104% EXE>LTR, 150%, 200%, ZOOM	Select one a fixed reduction or enlargement ratio, or enter a percentage between 25% and 400%.	12-5
	OPT:SPECIAL	2 IN 1 <b>OFF(1 IN 1)</b>	You can change the layout of copies on the print media.	12-6
<b>Ink</b>	1.CLEANING	BLACK/CYAN  YELLOW/MAGENTA  ALL	These two colors are cleaned together.  These two colors are cleaned together.  All four colors are cleaned.	23-10
	2.REPLACE INK	—	—	23-17
<b>Reports</b>	1.HELP LIST 2.AUTO DIAL 3.FAX ACTIVITY 4.TRANSMISSION 5.USER SETTINGS		Access the Reports menu.	11-2

Keys	Options	Descriptions	Page
<b>Receive Mode</b>	FAX ONLY <b>FAX/TEL</b> TAD:ANSWER MACH. MANUAL	Select the machine's Receive Mode.	6-1
<b>Fax Resolution</b>	<b>STANDARD</b> FINE S.FINE PHOTO	Black & white / color Black & white / color Black & white only Black & white only	7-3
<b>Hook/Hold</b>	See Control Panel Overview, pages 1-3 and 1-4.		
<b>Redial/ Pause</b>			
<b>Search/ Speed Dial</b>			
<b>Receive Modes</b>			
<b>Stop/Exit</b>			
<b>Scan to</b>			
<b>Color Fax Start</b>			
<b>Black Fax Start</b>			
<b>Shift + Scan to (Secure Feed)</b>			
<b>Color Copy</b>			
<b>Black Copy</b>			



The factory setting (option) is shown in bold.

# 5 Initial Setup

## Getting Started

---

### Setting Paper Type

You can choose the paper type you want to use.

- 1 Press **Menu/Set**, **1**, **1**.

1.PAPER TYPE

- 2 Press  to select **PLAIN, INK JET**, **GLOSSY** or **TRNSPRNCY** (TRANSPARENCY), and then press **Menu/Set**.

- 3 If you selected **GLOSSY**, press  to select **GLOSSY:4-COLOR** or **GLOSSY:3-COLOR**, and then press **Menu/Set**.

 **Note** The print quality of black ink varies depending on the kind of glossy paper you are using. Black ink is used when you select **GLOSSY:4-COLOR**. If the glossy paper you are using repels the black ink, select **GLOSSY:3-COLOR**, which simulates black ink by combining the three ink colors.

- 4 Press **Stop/Exit**.

 **Note** The MFC ejects paper with printed surfaces face up onto the output paper support in the front of the MFC. When you use transparencies, remove each sheet immediately from the output paper support to prevent a paper jam or curled pages.

### Setting Paper Size

You can use three sizes of paper for printing your faxes and copies — letter, legal and A4. When you change the kind of paper you have loaded in the MFC, you will need to change the setting for Paper Size so your MFC can fit the incoming fax on the page.

- 1 Press **Menu/Set**, **1**, **2**.

2.PAPER SIZE

- 2 Press  to select **LETTER, LEGAL** or **A4**, and then press **Menu/Set**.
- 3 Press **Stop/Exit**.

## Setting Date and Time

Your MFC displays the date and time, and prints it on every fax you send.

In the event of a power failure, you may have to reset the date and time. All other settings remain unaffected.

- 1 Press **Menu/Set**, **1**, **3**.

3. DATE/TIME

- 2 Enter the last two digits of the year, and then press **Menu/Set**.

YEAR: XX

- 3 Enter two digits for the month (for example, enter 09 for September, or 10 for October), and then press **Menu/Set**.

MONTH: XX

- 4 Enter two digits for the day (for example, 06), and then press **Menu/Set**.

DAY: XX

- 5 Enter the time in 24-hour format (for example, enter 15:25 for 3:25 P.M.), and then press **Menu/Set**.

TIME: XX:XX

- 6 Press **Stop/Exit**.

The LCD now displays the date and time you set whenever the MFC is in Standby mode.

## Setting Station ID

You can store your name, fax number and telephone number in this setting. The name and fax number will be printed on the fax cover pages and all fax pages that you send.

- 1 Press **Menu/Set**, **1**, **4**.

4. STATION ID

- 2 Enter your fax number (up to 20 digits), and then press **Menu/Set**.

FAX:

You must enter a fax number to proceed.

- 3 Enter your telephone number (up to 20 digits) and press **Menu/Set**. If your telephone number and fax number are the same, enter the same number again.

TEL:



The telephone number you enter is used only for Cover Page features. (See *Composing Electronic Cover Page*, page 7-7.)

- 4 Use the dial pad to enter your name (up to 20 characters), and then press **Menu/Set**. (See *Entering Text*, page 5-3.)

NAME:

- 5 Press **Stop/Exit**.

The LCD returns to the date and time.



If your Station ID has already been programmed, the LCD prompts 1 to make a change, or 2 to exit without changing.

## Entering Text

When you are setting certain functions, such as the Station ID, you may need to type text into the MFC. Most number keys have three or four letters printed above them. The keys for 0, #, and ✖ do not have printed letters because they are used for special characters.

By pressing the appropriate number key repeatedly, you can access the character you want.

Press Key	one time	two times	three times	four times
<b>2</b>	A	B	C	2
<b>3</b>	D	E	F	3
<b>4</b>	G	H	I	4
<b>5</b>	J	K	L	5
<b>6</b>	M	N	O	6
<b>7</b>	P	Q	R	S
<b>8</b>	T	U	V	8
<b>9</b>	W	X	Y	Z

## Inserting Spaces

To enter a space, press  once between numbers and twice between characters.



## Making Corrections

If you entered a letter incorrectly and want to change it, press  to move the cursor after the last correct letter. Then press **Stop/Exit**; all letters above and to the right of the cursor will be deleted. Re-enter the correct characters. You can also back up and type over incorrect letters.

## Repeating Letters

If you need to enter a character that is assigned to the same key as the previous character, press  to move the cursor to the right.

## Special Characters and Symbols

Press ✖, # or 0, and then press  or  to move the cursor under the special character or symbol you want. Then press **Menu/Set** to select it.

Press ✖ for (space) ! “ # \$ % & ’ ( ) \* + , - . /

Press # for ; < = > ? @ [ ] ^ \_

Press 0 for É À È Ê Î Ç Ë Ö 0

## NOTICE

The Telephone Consumer Protection Act of 1991 makes it unlawful for any person to use a computer or electronic device to send any message via a telephone fax machine unless such messages clearly contain, in a margin at the top or bottom of each transmitted page, or on the first page of the transmission, the date and time it is sent and an identification of the business or other entity or other individual sending the message and the telephone number of the sending machines or such business, other entity or individual.

In order to program this information into your MFC, complete the steps described on page 5-2.



If you do not enter a fax number, no additional information can be entered.

### Setting the Ring Volume

- 1 Press **Menu/Set, 1, 5, 1.**

1. RING

- 2 Press  or select (**OFF, LOW** or **HIGH**), and then press **Menu/Set**.

- 3 Press **Stop/Exit**.

—OR—

You can adjust the ring volume when your MFC is idle. You can turn the ring **OFF** or you can select a ring volume level.

Press  to adjust the volume level. With each key press, the MFC rings so you can hear the active setting as the LCD shows it. Each key press changes the volume. The new setting will remain until you change it again.

### Setting the Beeper Volume

You can set the beeper to **LOW, HIGH** or **OFF**. The default setting is **LOW**. When the beeper is set to **LOW** or **HIGH**, the MFC beeps every time you press a key or make an error and when fax sending or receiving is finished.

- 1 Press **Menu/Set, 1, 5, 2.**

2. BEEPER

- 2 Press  to select your option.

- 3 When the LCD shows the option you want, press **Menu/Set**.

Press **Stop/Exit**.

## Setting the Speaker Volume

1 Press **Menu/Set, 1, 5, 3.**

3. SPEAKER

2 Press  to select **LOW, MED, HIGH** or **OFF**, and then press **Menu/Set**.

3 Press **Stop/Exit**.

—OR—

If you are using **Hook/Hold**, you can adjust the speaker volume while dialing. You can turn the speaker off or you can select a speaker volume level. The default setting is the lowest volume.

Press  to adjust the volume level. With each key press, the volume changes as the LCD shows the active setting. The new setting will remain until you change it again.

## Setting the Handset Volume

1 Press **Menu/Set, 1, 5, 4.**

4. HANDSET

2 Press  to select **HIGH** (or **LOW**), and then press **Menu/Set**.

3 Press **Stop/Exit**.

—OR—

You can adjust the handset volume any time you are talking on the telephone. There are two handset volume levels, **LOW** and **HIGH**. The default setting is **LOW**.

Press  to adjust the volume level. The LCD shows the setting you are choosing. The new setting will remain until you change it again.



## Choosing the Handset Volume (For Volume Amplify)

Before you begin to use the machine, you must decide if you need to set the handset volume to **VOL AMPLIFY: ON** for a user who is hearing-impaired. The AMPLIFY volume level complies with FCC standards.

### *VOLUME AMPLIFY: OFF*

This default setting is appropriate if *none* of the users are hearing-impaired.

During a conversation, users can press Volume  on the control panel to adjust the volume to **LOW** or **HIGH**. When the handset is replaced, the handset volume will remain until you change it again.

### *VOLUME AMPLIFY: ON—TEMPORARY*

This setting is appropriate if *some* of the users are hearing-impaired. During a conversation, users can press Volume  on the control panel to adjust the volume to **LOW**, **HIGH** or **AMPLIFY**. When the handset is replaced, the handset volume returns to the default setting of **LOW**.

### *VOLUME AMPLIFY: ON—PERMANENT*

Choose **VOL AMPLIFY: ON—PERMANENT** if *all* of the users are hearing-impaired. During a conversation, users can press Volume  on the control panel to adjust the volume to **LOW**, **HIGH** or **AMPLIFY**. When the handset is replaced, the handset volume returns to the default setting of **AMPLIFY**.



When you press Volume  on the control panel to adjust the volume, the LCD shows the setting you are choosing. Each key press changes the volume to the next setting.

## **WARNING**

**It is important that you do NOT choose PERMANENT unless ALL the users are hearing-impaired.** Otherwise, the default setting of **AMPLIFY** may damage the hearing of some users.

## Setting Volume Amplify

Please carefully read *Choosing the Handset Volume* on page 5-6 before you do the following steps:

- 1 Press **Menu/Set, 1, 5, 5**.

5.VOLUME AMPLIFY

- 2 If *none* of the users are hearing-impaired,

VOL AMPLIFY:ON?

press  to select VOL AMPLIFY:OFF?, and then press **Menu/Set** and go to Step 4—**OR**—

If *some* or *all* of the users are hearing-impaired, select VOL AMPLIFY:ON?, and then press **Menu/Set**.

- 3 If all the users are hearing-impaired,

PERMANENT?

press  to select PERMANENT?,

TEMPORARY?

and then press **Menu/Set**—**OR**—

If only *some* of the users are hearing-impaired, select TEMPORARY?, and then press **Menu/Set**.

- 4 Press **Stop/Exit**.

## Turning On Automatic Daylight Savings Time

You can set the machine to change automatically for Daylight Savings Time. It will reset itself forward one hour in the Spring and backward one hour in the Fall. Make sure you have set the correct day and time in the DATE/TIME setting.

- 1 Press **Menu/Set, 1, 6.**

6. AUTO DAYLIGHT

- 2 Press  to select **ON** (or **OFF**), and then press **Menu/Set**.

- 3 Press **Stop/Exit**.

## Setting Tone/Pulse Dialing Mode

Your MFC comes set to accommodate tone dialing service (multi-frequency). If you have pulse dialing service (rotary), you need to change the dialing mode.

- 1 Press **Menu/Set, 1, 7.**

7. TONE/PULSE

- 2 Press  to select **PULSE** (or **TONE**), and then press **Menu/Set**.

- 3 Press **Stop/Exit**.

## Memory Storage

In the event of a power failure, all settings in the **GENERAL SETUP, SETUP RECEIVE, SET AUTO DIAL, SETUP REPORTS, REMOTE FAX OPT, COPY**, plus the **COVERPG SETUP** and **COVERPAGE MSG** settings (from **SETUP SEND**) are stored permanently. You may have to reset the date and time.

# 6 Setup Receive

## Basic Receiving Operations

### Choosing the Receive Mode

There are three different receive modes for your MFC. You may choose the mode that best suits your needs by pressing **Receive Mode** repeatedly until the LCD shows the setting you want to use.

LCD	How it works	When to use it
<b>FAX ONLY</b> (automatic receive)	The MFC automatically answers every call as a fax.	For dedicated fax lines. You cannot receive a voice call but you can call out.
<b>FAX/TEL*</b> (fax/telephone)	The MFC controls the line and automatically answers every call. If the call is a fax it will receive the fax. If the call is not a fax it will ring (double-ring) for you to pick up the call.	You cannot have an answering machine on the same line, even if it is on a separate wall jack on the same line. You cannot use the telephone company's Voice Mail in this mode.
<b>TAD:ANSWER MACH.</b> (external telephone answering device)	The external TAD automatically answers every call. Voice messages are stored on the external TAD. Fax messages are printed.	Use this mode if you have an external answering machine on your phone line.
<b>MANUAL</b> (manual receive)	You control the phone line and must answer every call yourself.	Use this mode when you are using a computer modem on the same line or if you receive very few fax messages. You can also use this mode with Distinctive Ring.

\*In FAX/TEL mode you must set the Ring Delay and F/T Ring Time. If you have extension phones on the line, keep the Ring Delay set to **4** rings.

## To Select or Change Your Receive Mode

- 1 Press **Receive Mode**. The LCD shows the selection.

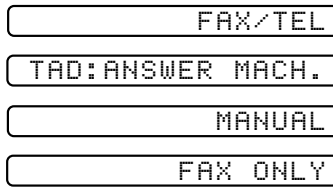

- 2 Continue to press **Receive Mode** until your new selection appears. After two seconds the LCD returns to the date and time display, along with your new Receive Mode setting.



If you are changing the Receive Mode while in another operation, the LCD returns to that operation.

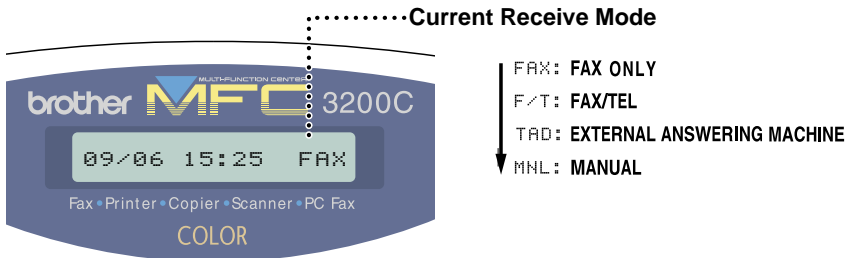



## Setting Ring Delay

The Ring Delay setting determines the number of times the MFC rings before it answers. If you have extension phones on the same line as the MFC, or subscribe to the telephone company's Distinctive Ring service, keep the Ring Delay default setting of 4. (See *Easy Receive*, page 6-3 and *Operation from Extension Telephones*, page 6-5.)





- 1 Press **Menu/Set**, **2**, **1**, **1**.



- 2 Press  or  to select how many times the line rings before the MFC answers (00–04), and then press **Menu/Set**. If you select 00, the line doesn't ring at all.
- 3 Press **Stop/Exit**.

## Setting the F/T Ring Time (For FAX/TEL Mode Only)

If you set the receive mode to FAX/TEL, you'll need to determine how long the MFC will send you its special double-ring when you have a voice call. This ringing happens *after* the initial ringing from the phone company. Only the MFC rings, for 20, 30, 40 or 70 seconds; no other phones on the same line ring the special double-ring. However, you can answer the call on any extension phone (in a separate wall jack) on the same line as the MFC. (See *Operation from Extension Telephone*, page 6-5.)

- 1 Press **Menu/Set**, **2**, **1**, **2**. 
- 2 Press  or  to select how long the fax machine will ring to alert you that you have a voice call, and then press **Menu/Set**. 
- 3 Press **Stop/Exit**.

Now, when a call comes in and the MFC is set to FAX/TEL mode, all phones on this line will ring the number of times you selected in Ring Delay.

You can let the MFC answer and detect if it's a fax or voice call. If it's a fax call, the MFC prints the fax. If it's a voice call, the MFC signals you with a double-ring for the length of time you selected in F/T Ring Time.



Even if the caller hangs up during the double-ringing, the MFC continues for the set time.

## Easy Receive

When you use this feature, you don't have to press **Black Fax Start** when you answer a fax call and hear calling beeps. Just hold the handset and wait a few seconds. When you see **RECEIVING** on the LCD or when you hear "chirps" through the handset of an extension phone connected to another wall jack, just replace the handset. Your fax machine does the rest. Selecting **ON** allows the MFC to receive fax calls automatically, even if you lift the handset of an extension or external phone. Selecting **SEMI** lets the MFC receive the call only if you've answered it at the MFC. Selecting **OFF** means you'll have to activate the MFC yourself, by pressing **Black Fax Start** or by pressing \* **5 1** if you are not at your MFC.

(See *Operation from Extension Telephones*, page 6-5 and *For FAX/TEL Mode Only*, page 6-5.)



If you've set the feature to **ON**, but your MFC doesn't automatically connect a fax call when you lift an external or extension phone handset, press the Fax Receive code \* **5 1**. At the MFC, lift the handset and then press **Black Fax Start**.



If you send faxes from a computer on the same phone line and the MFC intercepts them, set Easy Receive to **OFF**.

1 Press **Menu/Set**, **2**, **1**, **3**.

3.EASY RECEIVE

2 Use  to select **ON**, **SEMI**, or **OFF**, and then press **Menu/Set**.

3 Press **Stop/Exit**.

## Printing a Reduced Incoming Fax (Auto Reduction)

You can always reduce the size of an incoming fax to a fixed percentage, regardless of the size of the paper in your MFC. **ON** lets your MFC choose the level of reduction for you.

1 Press **Menu/Set**, **2**, **1**, **5**.

5.AUTO REDUCTION

2 Use  to select **ON** (or **OFF**), and then press **Menu/Set**.

3 Press **Stop/Exit**.



If incoming faxes show that information in the left and right margins has been cut off, make sure this Auto Reduction feature is turned on.

### FOR YOUR INFORMATION

If one or more ink cartridges are empty, the MFC will stop printing to protect the print heads; black & white faxes will be received into memory. The MFC-3200C's "handshake" will request that color faxes be sent as black & white. If the sending machine has the feature to send color faxes in black & white, they can be received into memory also.

Replace the empty ink cartridges to print the faxes from memory.

If the MFC runs out of paper, it stops printing and receives faxes into memory. Add paper, and then press **Black Fax Start** to print the faxes.

# Advanced Receiving Operations

---

## Operation from Extension Telephones

If you answer a fax call on an extension phone or on an external phone in the EXT. jack, you can make your MFC take over by using the Fax Receive Code. When you press the Fax Receive Code ✕ **5 1**, the MFC starts to receive a fax. (See *Easy Receive*, page 6-3.)

If the MFC answers a voice call and double-rings for you to take over, use the Telephone Answer Code **# 5 1** to take the call at an extension phone. (See *Setting F/T Ring Time*, page 6-3.)

If you answer a call, and no one is on the line, assume you're receiving a fax. At the MFC phone press **Black Fax Start**, and then hang up. At an extension phone, press ✕ **5 1**, wait for fax receiving tones (chirps), and then hang up. At an external phone, press ✕ **5 1** and wait for the phone to be disconnected before you hang up (the LCD shows **RECEIVING**). (Your caller will have to press **Black Fax Start** to send the fax.)

## For FAX/TEL Mode Only

When the MFC is in FAX/TEL mode, it will use the F/T Ring Time (double-ringing) to alert you to a voice call. If you're at the MFC, you can lift the handset to answer.

If you're at an extension phone, you'll need to lift the handset during the F/T Ring Time, and then press **# 5 1** between the double-rings. If no one is on the line or if someone wants to send you a fax, send the call back to the MFC by pressing ✕ **5 1**.

## Using a Cordless External Handset

If your cordless telephone is connected to the EXT. jack of the MFC and you typically carry the cordless handset elsewhere, it is easier to answer calls during the Ring Delay. If you let the MFC answer first, you will have to answer using the cordless and then go to the MFC so you can press **Hook/Hold** to transfer the call to the cordless handset.

## Changing the Remote Codes

Remote Codes might not work with some telephone systems. The preset Fax Receive Code is ✕ **5 1**. The preset Telephone Answer Code is **# 5 1**.



If you are always disconnected when accessing your external TAD remotely, try changing the Fax Receive Code from ✕ **5 1** to **###** and the Telephone Answer Code from **# 5 1** to **999**.

1 Press **Menu/Set**, **2**, **1**, **4**.

2 Press  to select **ON** (or **OFF**),  
and then press **Menu/Set**.

4.REMOTE CODE

REMOTE ACT.:ON?

3 If you want to, enter a new Fax Receive Code, and then press **Menu/Set**.

FAX RECEIVE:\*51

4 If you want to, enter a new Telephone Answer Code, and then press **Menu/Set**.

TEL ANSWER:#51

5 Press **Stop/Exit**.

## Printing a Fax in Memory

If you set Fax Storage to **ON** for remote retrieval, you can still print a fax from the memory when you are at your MFC. (See *Setting Fax Storage*, page 10-2.)

1 Press **Menu/Set**, **2**, **5**, **4**.

4.PRINT FAX

2 Press **Black Fax Start**.

3 After printing is finished, press **Stop/Exit**.

## Polling

Polling is the process of retrieving faxes from another MFC. You can use your fax machine to “poll” other machines, or you can have someone poll your MFC.

All parties involved in polling need to set up their fax machines to accommodate polling. When someone polls your MFC to receive a fax, they pay for the call; if you poll someone’s fax machine to receive a fax, you pay for the call.



Some fax machines do not respond to the Polling feature.

## Setting Up Polling Receive

Polling Receive is when you call another fax machine to receive a fax from it.

1 Press **Menu/Set**, **2**, **1**, **6**.

6.POLLING RX

2 Press  to select **POLLING RX: ON**,  
and then press **Menu/Set**.



3 Enter the fax number you are polling.

4 Press **Black Fax Start**.  
The LCD shows **DIALING**.





## Setting Up Sequential Polling Receive

Your MFC can request documents from several fax units in a single operation. Afterward, a Sequential Polling Report will be printed.

- 1 Press **Menu/Set, 2, 1, 6.** 
- 2 Press  to select **POLLING RX: ON**, and then press **Menu/Set**.
- 3 Specify the destination fax machines you wish to poll using One Touch, Speed Dial, a Group or the dial pad. You must press **Menu/Set** between each location.
- 4 Press **Black Fax Start**.  
Your MFC will poll each number or group number in turn for a document.

## Canceling a Scheduled Job

You can cancel tasks you've scheduled, such as Delayed Fax or Polling Transmit. (See *Checking Job Status*, page 7-5.)

- 1 Press **Menu/Set, 2, 6**. Any waiting jobs appear on the LCD. If no job is waiting, the LCD shows **NO JOB WAITING**. 
- 2 If you have more than two jobs waiting, press  to select the job you want to cancel, and then press **Menu/Set**.  
—OR—  
If you have only one job waiting, go to Step 3.
- 3 Press **1** to cancel—OR—Press **2** to exit without canceling.  
To cancel another job, return to Step 2.
- 4 Press **Stop/Exit**.

# 7 Setup Send

## Before You Begin

Before you begin sending faxes, please be sure to read all the instructions and cautions listed below for placing originals in the automatic document feeder.

### Using the ADF (Automatic Document Feeder)

- Documents must be between 3.5 and 8.5 inches wide and 5 and 14 inches long.
- Make sure you place originals **face down, top edge first**.
- Adjust the paper guides to fit the width of your document.

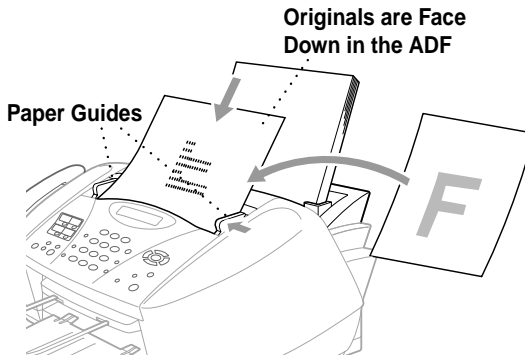

- The automatic document feeder (ADF) can hold up to 20 pages, feeding each one individually through the MFC. Use standard (20 lb./75g/m<sup>2</sup>) paper when using the ADF.

Fan the paper, and then stagger the pages in the ADF as shown:

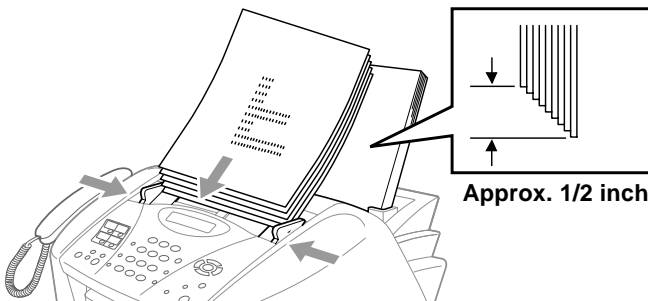

- ⊘ **DO NOT** use curled, wrinkled, folded, or ripped paper, or paper with staples, paper clips, paste or tape attached. **DO NOT** use cardboard, newspaper or fabric.

Make sure documents written with ink are completely dry.

## Sending Faxes with Multiple Settings

When you send a fax you can choose any combination of these settings: set the contrast or resolution; send using overseas mode, delayed fax, polling transmission or real time transmission.

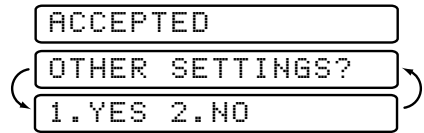

After each menu selection is accepted, the LCD will ask if you want to enter other settings:

- Press **1** if you want to select additional settings. The LCD returns to the **SETUP SEND** menu

—OR—



Press **2** if you are finished choosing settings, and then go to the next step.

## Basic Sending Operations

---

### Contrast

If your document is very light or very dark, you might want to set the contrast. Use **S.LIGHT** to send a very light document. Use **S.DARK** to send a very dark document.

- 1 Place the original face down in the ADF.
- 2 Press **Menu/Set, 2, 2, 1**.  

- 3 Press  to select **AUTO, S.LIGHT** or **S.DARK**, and then press **Menu/Set**.
- 4 Press **1** if you want to select additional settings. The LCD returns to the **SETUP SEND** menu—OR—Press **2** if you are finished choosing settings, and then go to Step 5.
- 5 Enter a fax number.
- 6 Press **Black Fax Start** to send a fax.

## Fax Resolution

When you have a document in the ADF, you can use the **FAX Resolution** key to temporarily change the setting. Press **FAX Resolution** repeatedly until the LCD shows the setting you want.

—OR—

You can change the default setting.

- 1 Press **Menu/Set**, **2**, **2**, **2**.

2. FAX RESOLUTION

- 2 Press  to select the resolution you want, and then press **Menu/Set**.

- 3 Press **Stop/Exit**.

**STANDARD**—Suitable for most typed documents.

**FINE**—Good for small print; transmits a little slower than Standard resolution.

**S. FINE**—Good for small print or artwork; transmits slower than Fine resolution (black and white only).

**PHOTO**—Use when original has varying shades of gray; this is the slowest transmission time (black and white only).

## Manual Transmission

Manual transmission lets you hear the dial tone, ringing and fax receiving tones while sending a fax.

- 1 Place the original face down in the ADF.
- 2 Pick up the handset and listen for a dial tone—**OR**—press **Hook/Hold** and listen for a dial tone.
- 3 Enter the fax number you want to call. You can enter the digits using the dial pad, or you can enter a One Touch or Speed Dial number or you can call using Search. (See *One Touch Dialing*, page 8-5.)
- 4 When you hear the fax tone, press **Black Fax Start**.
- 5 Replace the handset.

## Automatic Transmission

This is the easiest way to send a fax. **IMPORTANT:** Do **not** pick up the handset, or press **Hook/Hold** to listen for a dial tone.

- 1 Place the original face down in the ADF.
- 2 Enter the fax number using the dial pad, One Touch, Speed Dial or Search. (See *Speed Dialing*, page 8-5.)
- 3 Press **Black Fax Start**.

## Color Fax Transmission

Your MFC allows you to transmit a color fax.

- 1 Place the original face down in the ADF.
- 2 Enter the fax number using the dial pad, Speed Dial or Search.
- 3 Press **Color Fax Start**.



When you are sending a color fax, the MFC starts sending the fax without scanning the original into memory.

## Manual and Automatic Fax Redial

*If you're sending a fax manually* and the line is busy, press **Redial/Pause** to try again. Anytime you want to make a second call to the last number dialed, press **Redial/Pause** to save time.

*If you're sending a fax automatically* and the line is busy, the MFC will automatically redial (up to three times at 5 minute intervals).

## Dual Access (Not Available for Color Faxes)

You can scan *up to* 50 documents into the fax memory, even while the machine is receiving or sending another fax (from memory). You can set temporary settings for each fax you're scanning, except Polling.

If you try to scan and store a 51st fax, the MFC will send it immediately, without storing it in memory.



If you get a **OUT OF MEMORY** message while scanning the first page of a fax, press **Stop/Exit** to cancel scanning. If you get a **OUT OF MEMORY** message while scanning a subsequent page, you can press **Black Fax Start** to transmit the pages scanned so far, or press **Stop/Exit** to cancel the operation.

- 1 Place the original face down in the ADF.
- 2 Enter the fax number.
- 3 Press **Black Fax Start**. The MFC scans the original and the LCD shows the job number (#XXX) of the fax and how much memory is available. Then the MFC starts dialing. You can immediately repeat Steps 1 to 3 for the next fax.



Your machine normally operates in Dual Access mode. However, to send a color fax, you must override Dual Access and use Real Time Transmission.



The number of pages you can scan into memory varies with the data they contain.

## Real Time Transmission

When you are sending a fax, the MFC will scan originals into memory before sending. Then, as soon as the phone line is free, the MFC will start dialing and sending the fax. If memory becomes full, the MFC will send the document in real time (even if **REAL TIME TX** is set to **OFF**).

Sometimes you may want to send an important document immediately, without waiting for memory transmission. You can set **REAL TIME TX** to **ON**.

1 Place the original face down in the ADF.

2 Press **Menu/Set, 2, 2, 5**.

5. REAL TIME TX

3 To change the default setting, press  to select **ON** (or **OFF**), and then press **Menu/Set**.

Go to Step 5—**OR**—For the next fax transmission only, press  to select **NEXT FAX ONLY**, and then press **Menu/Set**.

4 For the next fax only, press  to select **ON** (or **OFF**), and then press **Menu/Set**.

5 Press **1** if you want to select additional settings. The LCD returns to the **SETUP SEND** menu—**OR**—Press **2** if you are finished choosing settings, and then go to Step 6.

6 Enter fax number, and then press **Black Fax Start**.



If you are sending a color Fax, the MFC will send it in real time even if **REAL TIME TX** is set to **OFF**.

## Checking Job Status

Check which jobs are still waiting in memory to be sent. (If no jobs are waiting, the LCD shows **NO JOB WAITING**.) (See *Canceling a Job in Memory*, page 7-6.)



1 Press **Menu/Set, 2, 6**.

2 If you have multiple jobs waiting, press  to scroll through the list.

3 Press **Stop/Exit**.

## Canceling a Job in Memory

You can cancel tasks you've scheduled, such as Polling Transmit, or faxes waiting in Memory to be sent. (See *Checking Job Status*, page 7-5.)

- 1 Press **Menu/Set, 2, 6**.  
Any waiting jobs appear on the LCD.  
If no jobs are waiting, the LCD shows **NO JOB WAITING**.  

- 2 If you have more than two jobs waiting, press  **or**  to select the job you want to cancel, and then press **Menu/Set**.  
—**OR**—  
If you have only one job waiting, go to Step 3.
- 3 Press **1** to cancel—**OR**—Press **2** to exit without canceling.  
To cancel another job, return to Step 2.
- 4 Press **Stop/Exit**.

# Advanced Sending Operations

---

## Composing Electronic Cover Page

The cover page is generated at the receiving party's machine. Your cover page includes the name stored in the One Touch or Speed Dial memory. If you're dialing manually, the name is left blank.

The cover page indicates your Station ID and the number of pages you're sending. If you have Cover page Setup set to ON, the number of pages remains blank. (**Menu/Set, 2, 2, 7**) (See *Setting Station ID*, page 5-2.)

You can select a comment to include on your cover page.

- 1. COMMENT OFF
- 2. PLEASE CALL
- 3. URGENT
- 4. CONFIDENTIAL

Instead of using one of the comments above, you can enter up to two customized messages, each 27 characters long. Use the chart on page 5-3 to help enter characters. (See *Composing Your Own Comments* below.)

- 5. (USER DEFINED)
- 6. (USER DEFINED)

Most of the **SETUP SEND** menu selections are temporary settings that allow you to make adjustments for each document you send. However, so you can set up your cover page and cover page comments in advance, the Cover Page Setup and Cover Page Message features will change the default settings.

## Composing Your Own Comments

You can set up two custom comments.



- 1 Press **Menu/Set, 2, 2, 8**. 8. COVERPAGE MSG
- 2 Press  to choose position 5 or 6 for your customized comment, and then press **Menu/Set**.
- 3 Use the dial pad to enter your customized comment, and then press **Menu/Set**. (See *Entering Text*, page 5-3.)
- 4 Press **1** if you want to select additional settings. The LCD returns to the **SETUP SEND** menu—**OR**—Press **2** to exit.



## Cover Page for the Next Fax Only

Make sure the Station ID is set up (see page 5-2). This feature does not work without the Station ID.



You can set the fax to send a cover page with a particular document. This cover page will include the number of pages in your document.

- 1 Place the original face down in the ADF.
- 2 Press **Menu/Set, 2, 2, 7.** 7. COVERPG SETUP
- 3 When LCD shows **NEXT FAX ONLY?**, and then press **Menu/Set**.
- 4 Press  to select **ON** (or **OFF**), and then press **Menu/Set**.
- 5 Press  to select one of the standard or custom comments, and then press **Menu/Set**.
- 6 Enter two digits to indicate the number of pages you are sending, and then press **Menu/Set**. (For example, press **0, 2** for 2.)  
(Enter **0 0** to leave the number of pages blank. If you make a mistake, press  to back up and re-enter the number of pages.)
- 7 Press **1** if you want to select additional settings. The LCD returns to the **SETUP SEND** menu—**OR**—Press **2** if you are finished choosing settings.
- 8 Enter the fax number you're calling.
- 9 Press **Black Fax Start**.

## Always Send a Cover Page

Make sure the Station ID is set up (see page 5-2). This feature does not work without the Station ID.

You can set the MFC to send a cover page whenever you send a fax. The number of pages in your fax is not included when you use this setting.

- 1 Press **Menu/Set, 2, 2, 7.** 7. COVERPG SETUP
- 2 Press  to select **COVERPAGE:ON?**, and then press **Menu/Set**.
- 3 If you selected **ON**, press  to select one of the standard or custom comments, and then press **Menu/Set**.
- 4 Press **1** if you want to select additional settings. The LCD returns to the **SETUP SEND** menu—**OR**—Press **2** to exit if you are finished choosing settings.

## Using a Printed Cover Page

If you prefer using a printed cover page that you can write on, you can print the sample page and attach it to your fax.

- 1 Press **Menu/Set, 2, 2, 7.**

7. COVERPG SETUP

- 2 Press  to select **PRINT SAMPLE?**, and then press **Menu/Set.**
- 3 Press **Black Fax Start.** Your MFC prints a copy of your cover page.
- 4 Press **Stop/Exit.**

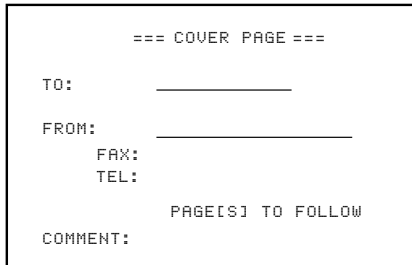

=== COVER PAGE ===

TO: \_\_\_\_\_

FROM: \_\_\_\_\_

FAX: \_\_\_\_\_

TEL: \_\_\_\_\_

PAGE[S] TO FOLLOW

COMMENT:

## Overseas Mode

After you send a fax using this feature, the feature turns itself off.

- 1 Place the original face down in the ADF.



- 2 Press **Menu/Set, 2, 2, 9.**

9. OVERSEAS MODE

- 3 Press  to select **ON** (or **OFF**), and then press **Menu/Set.**
- 4 Press **1** if you want to select additional settings. The LCD returns to the **SETUP SEND** menu—**OR**—Press **2** if you are finished choosing settings, and then go to Step 5.
- 5 Enter the fax number you're calling.
- 6 Press **Black Fax Start.**

## Delayed FAX (Not Available for Color Faxes)

During the day you can store *up to* 50 documents in memory for delayed sending. Transmission of these documents will begin at the time of day you enter in Step 3, which shows the time you entered last. Press **Menu/Set** to accept it, or enter another time for this fax.



- 1 Place the original face down in the ADF.
- 2 Press **Menu/Set**, **2**, **2**, **3**.  

- 3 Enter the time you want the fax to be sent (in 24-hour format), and then press **Menu/Set**. (For example, enter 19:45 for 7:45 PM.)
- 4 Press **1** to leave the originals waiting in the ADF—**OR**—Press **2** to scan the original into memory.  

- 5 Press **1** if you want to select additional settings. The LCD returns to the **SETUP SEND** menu—**OR**—Press **2** if you are finished choosing settings, and then go to Step 6.
- 6 Enter the fax number.
- 7 Press **Black Fax Start**. The MFC will wait to send the fax at the time you set.



*The number of documents you can scan into memory varies with the data they contain.*

## Delayed Batch Transmission (Not Available for Color Faxes)

Before sending the delayed faxes, your Brother machine will economize by sorting all the documents in memory by destination and scheduled time. All delayed faxes scheduled at the same time to the same fax number will be sent as one transmission.

- 1 Press **Menu/Set**, **2**, **2**, **4**.  

- 2 Press  to select **ON** (or **OFF**), and then press **Menu/Set**.
- 3 Press **Stop/Exit**.

## Setting Up Polled Transmit (Not Available for Color Faxes)

Polled Transmit is when you set up your MFC to wait with a document so another fax machine can retrieve it.

1 Place the original to be retrieved face down in the ADF.

2 Press **Menu/Set, 2, 2, 6.**

6. POLLED TX

3 Press  to choose **ON** (or **OFF**), and then press **Menu/Set**.

4 Press **1** to leave the originals waiting in the ADF—**OR**—Press **2** to scan the original into memory.

1. DOC 2. MEMORY

5 Press **1** if you want to select additional settings. The LCD returns to the **SETUP SEND** menu—**OR**—Press **2** if you are finished choosing settings, and then go to step 6.

6 Press **Black Fax Start**.



If you pressed **1** in Step 4, the original remains in the ADF until your MFC is polled. If you must use your MFC before the polled transmit occurs, you must first cancel this job.

## 8

# Auto Dial Numbers and Dialing Options

## Storing Numbers for Easy Dialing

You can set up your MFC to do three types of easy dialing: One Touch, Speed Dial and Groups for Broadcasting faxes.



*If you loose electrical power, auto dial numbers in memory will not be lost.*

### Storing One Touch Dial Numbers

You can store 8 fax/telephone numbers that you can dial by pressing one key (and **Black Fax Start**). To access numbers 5 to 8, hold down **Shift**. When you press a One Touch dial location, the LCD shows the name or number as the call is dialed. (See *One Touch Dialing*, page 8-5.)

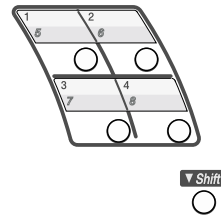

*One Touch keys are the 4 keys (numbers 5 to 8) located to the left of the dial pad.*



(For USA only) For your convenience, One Touch key **1** is pre-programmed for the Brother fax back system. You can change it by storing your own auto dial number in its place. (Please see *Changing One Touch and Speed Dial Numbers*, page 8-2.)

**1** Press **Menu/Set**, **2**, **3**, **1**.

1. ONE-TOUCH DIAL

**2** Press the One Touch key where you want to store a number. The LCD shows the location you selected.

**3** Enter a number (up to 20 digits), and then press **Menu/Set**. If you want to enter a pause in the dialing sequence (for example, to wait for an “outside line”), press **Redial/Pause** as you’re entering digits. A dash appears on the LCD. Pressing **Redial/Pause** enters a 3.5 second pause when the number is dialed.

**4** Use the dial pad to then enter the name (up to 15 characters), and then press **Menu/Set**. You can use the chart on page 5-3 to help you enter letters—**OR**—To store the number without a name, press **Menu/Set**.

NAME :

**5** Return to Step 2 to store another One Touch number—**OR**—Press **Stop/Exit**.

When you dial an auto dial number, the LCD shows the name you’ve stored, or, if you haven’t stored a name, the number you’ve stored.



If you need to store a pause longer than 3.5 seconds, press **Redial/Pause** two or more times.



You can store Groups (for Broadcasting) on the One Touch keys.

## Storing Speed Dial Numbers



You can store Speed Dial numbers, so when you dial you will have to press only five keys (Search/Speed Dial, #, the two-digit location, and Black Fax Start). The MFC has 100 Speed Dial locations.

- 1 Press **Menu/Set**, **2**, **3**, **2**. 2.SPEED-DIAL
- 2 Use the dial pad to enter a two-digit location (00-99), and then press **Menu/Set**. SPEED-DIAL? #
- 3 Enter the number (up to 20 digits), and then press **Menu/Set**. #05:
- 4 Use the dial pad to enter the name (up to 15 characters), and then press **Menu/Set**. You can use the chart on page 5-3 to help you enter letters—**OR**—Press **Menu/Set**, and then go to Step 5 to store the number without a name. NAME:
- 5 Return to Step 2 to store another Speed Dial number—**OR**—Press **Stop/Exit**.

## Changing One Touch and Speed Dial Numbers

If you try to store a One Touch or Speed Dial number in a location where a number is already stored, the LCD shows the current name stored there, and then prompts you to either:

1.CHANGE 2.EXIT

- 1 Press **1** to change the stored number—**OR**— Press **2** to exit without making a change.
- 2 Enter a new number, and then press **Menu/Set**.
  - If you want to erase the whole number, press **Stop/Exit** when the cursor is to the left of the digits. The letters above and to the right of the cursor will be deleted.
  - If you want to change a digit, use  or  to position the cursor under the digit you want to change, and then type over it.
- 3 Follow the directions beginning at Step 4 in *Storing One Touch Numbers* and *Storing Speed Dial Numbers*.

## Setting Up Groups for Broadcasting

Groups, which can be stored on a One Touch key or a Speed Dial location, allow you to send the same fax message to many fax numbers by pressing only a One Touch key and **Black Fax Start** or **Search/Speed Dial**, #, the two-digit location and **Black Fax Start**. **First**, you'll need to store each fax number as a One Touch or Speed Dial number. **Then**, you can combine them into a Group. *Each Group uses up a One Touch key or a Speed Dial location.* Finally, you can have up to six small Groups, or you can assign up to 107 numbers to one large Group.

(See *Storing One Touch Dial Numbers*, page 8-1 and *Storing Speed Dial Numbers*, page 8-2.)

- 1 Press **Menu/Set**, **2**, **3**, **3**.
- 2 Decide where you wish to store the Group  
—**AND**—

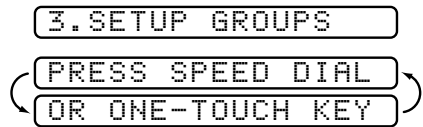

Press a One Touch Key  
—**OR**—

Press **Search/Speed Dial** and enter the two-digit location, and then press **Menu/Set**.

(For example, press One Touch key 2 for Group 1.)

- 3 Use the dial pad to enter the Group number, and then press **Menu/Set**.  
(For example, press **1** for Group 1.)
- 4 To include One Touch or Speed Dial numbers in the Group, enter them as if you were dialing.

The image shows an LCD display with the text 'SETUP GROUP:G0'.

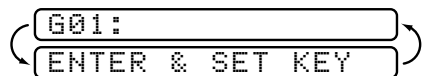

For example, for One Touch key **5**, and then press One Touch key **5**. For Speed Dial location 09, press **Search/Speed Dial**, then press **0**, **9** on the dial pad. The LCD shows \*05, #09.

The image shows an LCD display with the text 'G01:\*05#09\_'.

- 5 Press **Menu/Set** to accept the numbers for this Group.
- 6 Use the dial pad and the chart on page 5-3 to enter a name for the Group, and then press **Menu/Set**.  
(For example, NEW CLIENTS).
- 7 Press **Stop/Exit**.

The image shows an LCD display with the text 'NAME:'.

 You can print a list of all One Touch and Speed Dial numbers. (See Chapter 11, *Printing Reports*.)

# Dialing Options

---

You can use your MFC to make telephone calls by dialing manually or by using Search, One Touch or Speed Dial memory. When you dial an auto dial number, the LCD shows the name you've stored, or, if you haven't stored a name, the fax number you've stored.





## Manual Dialing

Manual dialing is simply pressing all of the digits of the phone number.

- 1 Pick up the handset—**OR**— press **Hook/Hold**.
- 2 When you hear a dial tone, dial the call using the dial pad.
- 3 If you pressed **Hook/Hold** to dial the call, pick up the handset when the other party answers. (The speaker works only one way; the other party won't be able to hear you unless you pick up the handset.)
- 4 To hang up, replace the handset.

## Search

You can search for names you have stored in One Touch and Speed Dial memories. (See *Storing One Touch Dial Numbers*, page 8-1 and *Storing Speed Dial Numbers*, page 8-2.)

- 1 Press **Search/Speed Dial**.
- 2 To search for numbers alphabetically by name, enter the first letter of the name, and then press  or .  
—**OR**—  
To search for numbers numerically by One Touch and Speed-Dial numbers, press .  

- 3 When the LCD shows the name you want to call, press **Black Fax Start**.
- 4 If you pressed **Hook/Hold** to dial the call, pick up the handset when the other party answers. (The speaker works only one way; the other party won't be able to hear you unless you pick up the handset.)
- 5 When the call is over, hang up.



## One Touch Dialing

- 1 Pick up the handset—**OR**—Press **Hook/Hold**.
- 2 When you hear a dial tone, press the One Touch key of the location you want to call. (See *Storing One Touch Dial Numbers*, page 8-1.)



To dial One Touch numbers 5 to 8, hold down **Shift** as you press the One Touch key.

- 3 If you pressed **Hook/Hold** to dial the call, pick up the handset when the other party answers. (The speaker works only one way; the other party won't be able to hear you unless you pickup the handset.)
- 4 To hang up, replace the handset.



If you try to use a One Touch location with no number stored in it, you'll hear a warning sound, and screen will display **NOT REGISTERED**. The display will return to normal after 2 seconds.



If you are sending a fax, press **Black Fax Start** after pressing the One Touch key. If you picked up the handset, press **Black Fax Start** when the receiving fax machine answers with fax tones.

## Speed Dialing

- 1 Pick up the handset—**OR**—Press **Hook/Hold**.  
(See *Storing Speed Dial Numbers*, page 8-2.)
- 2 When you hear a dial tone, press **Search/Speed Dial**, and then press # then the two-digit Speed Dial number.
- 3 If you pressed **Hook/Hold** to dial the call, pick up the handset when the other party answers. (The speaker works only one way; the other party won't be able to hear you unless you pickup the handset.)
- 4 To hang up, replace the handset.



If you are sending a fax, press **Black Fax Start** after pressing the Speed Dial number. If you picked up the handset, press **Black Fax Start** when the receiving fax machine answers with fax tones.

## Access Codes and Credit Card Numbers

Sometimes you may want to choose from among several long distance carriers when you make a call. Rates may vary depending upon the time and destination. To take advantage of low rates, you can store the access codes or long-distance carriers as One Touch and Speed Dial numbers. You can store these long dialing sequences by dividing them and setting them up separately in any combination. You can even include manual dialing using the dial pad. The combined number will be dialed in the order you entered it, as soon as you press **Black Fax Start**. (See *Storing One Touch Dial Numbers*, page 8-1.)

You store “555” on One Touch key **3** and “7000” on One Touch key **4**. If you press One Touch **3, 4** and **Black Fax Start** you can dial “555-7000”. To temporarily change a number, you can substitute part of the number with manual dialing using the dial pad. For example, to change the number to 555-7001 you could press One Touch **3** and then press **7, 0, 0, 1** using the dialing pad.



If you must wait for another dial tone at any point in the dialing sequence, store a pause at that point in the number by pressing **Redial/Pause**. Each key press adds a 3.5 second delay.

## Broadcasting (Not Available for Color Faxes)

Broadcasting is automatically sending the same fax message to multiple fax numbers. Using the **Menu/Set** key, you can include Groups, One Touch locations, Speed Dial locations plus up to 50 manually dialed numbers. If you did not use up any locations for Groups, access codes or credit card numbers, you can “broadcast” faxes automatically to up to 158 different locations from the MFC. However, available memory will vary with all types of jobs in memory and numbers of locations used for broadcasting. If you broadcast to more than the maximum locations available, you will not be able to set up transmissions using dual access and the timer.

The easiest way to broadcast is to press Group keys. You can include One Touch, Speed Dial, and manually dialed numbers in the same broadcast. (See *Setting Up Groups for Broadcasting*, page 8-3.)

You must press **Menu/Set** between each of these locations.

Use the **Search/Speed Dial** to help you choose the numbers easily.

After the broadcast is finished, a Broadcast Report will be printed automatically to let you know the results.

- To stop the broadcast in progress, press **Stop/Exit**. The LCD asks if you want to cancel the location that is being sent.
- Enter the long dialing sequence numbers as you normally would, but keep in mind that each key counts as one location, so the number of locations you can call becomes limited.
- If the line is busy or for other reasons a connection could not be made while broadcasting, the MFC will redial the number automatically.

- If the memory is full, press **Stop/Exit** to abort the job or if more than one page has been scanned, press **Black Fax Start** to send the portion that is in the memory.

- 1 Place the original face down in the ADF.
- 2 Enter a number using One Touch, Speed Dial, a Group number, Search or the dial pad.  
Example: Group number
- 3 Press **Menu/Set**. You will be prompted to press the next number.
- 4 Enter the next number.  
Example: Speed Dial
- 5 Press **Menu/Set**.
- 6 Enter the fax number.  
Example: Manual dialing using the dial pad.
- 7 Press **Black Fax Start**.  
Your MFC will read the original into memory and then start sending faxes to the numbers you entered.

## Pause

Press **Redial/Pause** to insert a 3.5 second pause between numbers. If you are dialing overseas, you can press **Redial/Pause** as many times as needed to increase the length of the pause.

## Hold

- 1 Press **Hook/Hold** to place a call on Hold.
- 2 You can replace the handset without disconnecting the call.
- 3 Pick up the MFC handset. (Picking up an extension telephone handset will not release the call from Hold.)

## Fax Redial

If you're sending a fax manually and the line is busy, press **Redial/Pause** to try again. Anytime you want to make a second call to the last number dialed, press **Redial/Pause** to save time.

If you're sending a fax automatically and the line is busy, the MFC will redial automatically up to three times at 5 minute intervals.

## **Tone/Pulse**

If you have pulse dialing service, but need to send tone signals (for example, for telephone banking), follow the directions below. If you have touch tone service, you do not need this feature to send tone signals.

- 1** Lift the handset.
- 2** Press **#**. Any digits dialed after this send tone signals.
- 3** When you hang up, the MFC returns to pulse dialing service.

# 9

# Telephone Services

## Custom Features

---

Your MFC supports the Distinctive Ring and Caller ID telephone services offered by some telephone companies.



If you have Voice Mail, Call Waiting, Call Waiting/Caller ID, RingMaster, an answering service, or an alarm system or other custom feature on your telephone line, it may create a problem in the operation of your MFC.

(See *Custom Features on a Single Line*, page 23-8.)

If you have Voice Mail on your phone line, please read the following carefully.

## Distinctive Ring

---

The term “Distinctive Ring” is used by Brother to identify a phone company service that is given *many names, depending on the telephone company you are using*. For example, this service may be called SmartRing, RingMaster, Teen-Ring, Ident-a-Call or Ident-a-Ring.

### What Does Your Telephone Company’s “Distinctive Ring” Do?

Your telephone company’s Distinctive Ring service allows more than one number on the same phone line. **If you need more than one phone number, it is an inexpensive alternative to paying for an additional line.** Each phone number has its own distinctive ring pattern, so you will know which phone number is ringing. This is one way you can have a separate phone number for your MFC.



Please consult your telephone company for availability and rates.

### What Does Brother’s “Distinctive Ring” Do?

The Brother machine has a Distinctive Ring feature that allows you to use your MFC to take full advantage of the telephone company’s Distinctive Ring service. You can dedicate the new phone number on your line to receiving only faxes.



You must purchase your telephone company’s Distinctive Ring service *before* you program the MFC to work with it.

## Do You Have Voice Mail?

If you have Voice Mail on the phone line on which you will install your new MFC, *there is a strong possibility that Voice Mail and the MFC will conflict with each other while receiving incoming calls.* **However, this Distinctive Ring feature allows the use of more than one number on your line, so both Voice Mail and the MFC can coexist peacefully.** If each one has a separate phone number, neither will interfere with the other's work.





If you decide to get the Distinctive Ring Service from the telephone company, you will need to follow the directions below to "register" the new Distinctive Ring pattern they provided, so your MFC can recognize its incoming calls.



You can change or cancel the Distinctive Ring pattern at any time. You can switch it off temporarily and later turn it back on. When you get a new fax number, make sure you reset this feature.

## Before You Choose the Ring Pattern to Register

You can register only one Distinctive Ring pattern with the MFC. Some ring patterns cannot be registered. Please refer to some popular ring pattern examples that will be provided from the phone company in the USA and Canada that are shown in the Brother compatibility table below.

Ring Pattern	Rings	
1	long - long	
2	short - long - short	
3	short - short - long	
4	very long (normal pattern)	







If the ring pattern the phone company provided cannot be registered by the fax, **please check for other available ring pattern choices from the phone company.**

- The MFC will answer only calls to its registered number.
- The first two rings are silent on the MFC. This is because the fax must «listen» to the ring pattern (compare it to the pattern that was "registered").
- If you program the MFC correctly, it will recognize the registered ring pattern of the "fax number" within two ring patterns and then automatically answer with a fax tone. When the "voice number" is called, the MFC will not interrupt the call.

## VERY IMPORTANT

If you have Voice Mail or a TAD (Telephone Answering Device) and want to keep one of your phone numbers dedicated only to fax calls, you must leave the MFC in **MANUAL** mode at all times while using the Distinctive Ring Feature. Here's why: **MANUAL** mode will never pick up a call by itself, since it is «Neutral». When the MFC is in this «neutral» mode, the Distinctive Ring Feature can be activated. The Distinctive Ring feature is actually an answering mode. So, do not activate **FAX ONLY** mode or **FAX/TEL** mode while using Distinctive Ring; otherwise, MFC will answer calls for *all* the numbers.

### Registering the Distinctive Ring Pattern

- 1 Set the MFC to **MANUAL** mode.
- 2 Press **Menu/Set, 2, 0, 1**. 
- 3 Press  or  to select **DISTINCTIVE:SET?**, and then press **Menu/Set**.
- 4 Press  or  to select the prestored ring pattern you want to assign, and then press **Menu/Set**. (You will hear each pattern as you scroll through the four patterns.) Be sure to choose the pattern assigned by the telephone company.
- 5 Press **Stop/Exit**.

## Caller ID

---



The Caller ID feature lets you use the Caller ID subscriber service offered by many local telephone companies. This service provides you, by means of the LCD, the name or telephone number of your caller as the line rings.

After a few rings, the LCD shows the telephone number of your caller (or name, if available). Once you pick up the handset, the Caller ID information disappears from the LCD, but the call information remains stored in the Caller ID memory.

- You will see the first 16 characters of the number (or name).
- **OUT OF AREA** display means call originates outside your Caller ID service area.
- **PRIVATE CALL** display means the caller has intentionally blocked transmission of information.
- **CALL PICKUP** display remains on the LCD when no Caller ID information was transmitted.

If both the name and number are received, the LCD shows only the name. You can print a list of Caller ID information received by your MFC. (See *Printing Caller ID List*, page 9-4.)

Caller ID service varies with different carriers. Call your local telephone company to determine the kind of service available in your area.

### Viewing Caller ID List

Caller ID memory stores information for up to thirty calls; when the thirty-first call comes in, information about the first call is erased. You can scroll through Caller ID information to review those calls made to your MFC.

- 1 Press **Menu/Set, 2, 0, 2.**

2. CALLER ID

- 2 Press  to select **DISPLAY #?**, and then press **Menu/Set.**

If the name was not received, it will not be displayed.

- 3 Press  to scroll through the Caller ID memory to select the Caller ID you want to view, and then press **Menu/Set.** The LCD shows the caller's name and number and the date and time of the call.

- 4 Press  to return to the Caller ID listing—**OR**—Press **Stop/Exit.**

### Printing Caller ID List

- 1 Press **Menu/Set, 2, 0, 2.**

2. CALLER ID

- 2 Press  to select **PRINT REPORT ?**, and then press **Menu/Set.**

- 3 Press **Black Fax Start.**



# 10

## Remote Fax Options

(Not Available for Color Faxes)

### Fax Forwarding/Paging

---



You cannot use Paging and Fax Forwarding at the same time.

You cannot use Paging and Fax Forwarding when Fax Storage is set to OFF.

#### Programming a Fax Forwarding Number

When Fax Forwarding is set to ON, your MFC stores the received fax in memory. Then it dials the fax number you've programmed and forwards the fax message.

- 1 Press **Menu/Set**, **2**, **5**, **1**.

1.FAX FWD/PAGING

- 2 Press  until the LCD shows **FAX FORWARD?**, and then press **Menu/Set**.

- 3 The LCD prompts you to enter the fax number where faxes will be forwarded. Enter the forwarding number (up to 20 digits), and then press **Menu/Set**.

FWD#:

- 4 Press **Stop/Exit**.

#### Programming Your Pager Number

When Paging is selected, your MFC dials the pager number you've programmed, and then dials your Personal Identification Number (PIN); this activates your pager so you will know that you have a fax message in the memory.

- 1 Press **Menu/Set**, **2**, **5**, **1**.

1.FAX FWD/PAGING

- 2 Press  until the LCD shows **PAGING?**, and then press **Menu/Set**.

- 3 Enter your pager phone number (up to 20 digits) followed by **# #**, and then press **Menu/Set**. Do not include the area code if it is the same as that of your MFC.

PAG#:

For example, **1 8 0 0 5 5 5 1 2 3 4 # #**.

4 If your pager requires a PIN, enter the PIN, press **#**, press **Redial/Pause**, enter your MFC telephone number followed by **##**, and then press **Menu/Set**.  
For example, **1 2 3 4 5 # Redial/Pause 1 8 0 0 5 2 1 2 8 4 6 ##**  
—OR—

If you do not need a PIN, press **Redial/Pause**, enter the fax number of your MFC followed by **##**, and then press **Menu/Set**.  
For example, **Redial/Pause 1 8 0 0 5 2 1 2 8 4 6 ##**

5 Press **Stop/Exit**.



You cannot change a Paging number or PIN remotely.





Press **Redial/Pause** for each 3.5 second delay, as needed.

## Setting Fax Storage

If you set Fax Storage to **ON**, you will be able to retrieve fax messages from another location using Fax Forwarding, Paging, or Remote Retrieval functions. The LCD will indicate when you have a fax stored in memory.

1 Press **Menu/Set, 2, 5, 2**. The LCD prompts you to choose a fax setting.

2 Press  or  to select **ON** (or **OFF**), and then press **Menu/Set**.

3 Press **Stop/Exit**.



If there are faxes in memory when you turn the Fax Storage **OFF**, the LCD prompts you to erase any faxes in memory.

If you press **1**, all fax data is erased and Fax Storage is turned off. If you press **2**, data is not erased and Fax Storage remains on.  
(See *Printing a Fax in Memory*, page 6-6.)

## Backup Print

If you've set **FAX STORAGE** to **ON**, your MFC *automatically prints* faxes as they are received into memory. This is a safety feature in case the power goes out so you won't lose your messages.

## Changing Remote Retrieval Access Code

---

Enter your Remote Access Code when the MFC picks up your call, so you can access features remotely. The access code is preset to 1 5 9 ✳, but you can change this. (See *Operation from Extension Telephones*, page 6-5.)

- 1 Press **Menu/Set**, **2**, **5**, **3**. 3.REMOTE ACCESS
- 2 Enter a three-digit number from 000 to 999, and then press **Menu/Set**. The “✳” cannot be changed. (Do not use the same digits that appear in your Fax Receive Code or Telephone Answer Code.)
- 3 Press **Stop/Exit**.

## Remote Retrieval

---

You can call your MFC from any fax machine using touch tone, then use the Remote Retrieval Access Code and other button presses to retrieve fax messages. *Cut out the Remote Retrieval Access Card on the last page and keep it in your wallet as an aid.*

### Using Remote Retrieval Access Code

- 1 Dial your fax number from a fax machine using touch tone.
- 2 When your MFC answers, immediately enter your Remote Retrieval Access Code (1 5 9 ✳).
- 3 The MFC signals the kinds of messages received:
  - 1 long beep — Fax message(s)**
  - No beeps — No messages**
- 4 The MFC prompts you with two short beeps to enter a command. If you wait longer than 30 seconds to enter a command, the MFC hangs up. If you enter an invalid command, the MFC beeps three times.
- 5 Press **9 0** to reset the MFC when you're finished.
- 6 Hang up.



If your MFC is set to **MANUAL** mode, you can access it by waiting about 2 minutes, and then entering the Remote Retrieval Access Code within 30 seconds.

## Remote Commands

Follow the commands below to access features remotely. When you call the MFC and enter your Remote Retrieval Access Code (1 5 9 ✳), the system will signal you with two short beeps to enter a remote command.

Remote Commands	Operation Details								
<b>95 Change Fax Forwarding /Paging setting</b> <table border="1" data-bbox="229 427 506 656"> <tr> <td data-bbox="229 427 506 465">1 OFF</td> <td data-bbox="506 427 1064 583" rowspan="4">If you hear one long beep, the change is accepted. If you hear three short beeps, you cannot change it because the conditions have not been met (Example: registering paging number). You can register your fax forwarding number by using 4. FAX FWD NO. (see page 10-5). Once you have registered the number, the MFC will change automatically to FAX FWD:ON mode.</td> </tr> <tr> <td data-bbox="229 465 506 503">2 Fax Forwarding</td> </tr> <tr> <td data-bbox="229 503 506 541">3 Paging</td> </tr> <tr> <td data-bbox="229 541 506 579">4 FAX FWD No.</td> </tr> <tr> <td data-bbox="229 579 506 618">6 Fax Storage ON</td> <td data-bbox="506 579 1064 656" rowspan="2">You can turn FAX STORAGE to ON or OFF.</td> </tr> <tr> <td data-bbox="229 618 506 656">7 Fax Storage OFF</td> </tr> </table>	1 OFF	If you hear one long beep, the change is accepted. If you hear three short beeps, you cannot change it because the conditions have not been met (Example: registering paging number). You can register your fax forwarding number by using 4. FAX FWD NO. (see page 10-5). Once you have registered the number, the MFC will change automatically to FAX FWD:ON mode.	2 Fax Forwarding	3 Paging	4 FAX FWD No.	6 Fax Storage ON	You can turn FAX STORAGE to ON or OFF.	7 Fax Storage OFF	
1 OFF	If you hear one long beep, the change is accepted. If you hear three short beeps, you cannot change it because the conditions have not been met (Example: registering paging number). You can register your fax forwarding number by using 4. FAX FWD NO. (see page 10-5). Once you have registered the number, the MFC will change automatically to FAX FWD:ON mode.								
2 Fax Forwarding									
3 Paging									
4 FAX FWD No.									
6 Fax Storage ON	You can turn FAX STORAGE to ON or OFF.								
7 Fax Storage OFF									
<b>96 Retrieve a fax</b> <table border="1" data-bbox="229 699 506 817"> <tr> <td data-bbox="229 699 506 756">2 Retrieve all faxes</td> <td data-bbox="506 699 1064 756">Enter the number of a remote fax machine to receive stored fax message(s). (See page 10-5.)</td> </tr> <tr> <td data-bbox="229 756 506 817">3 Erase fax from the memory</td> <td data-bbox="506 756 1064 817">If you hear one long beep, you can erase fax message(s) from the memory.</td> </tr> </table>	2 Retrieve all faxes	Enter the number of a remote fax machine to receive stored fax message(s). (See page 10-5.)	3 Erase fax from the memory	If you hear one long beep, you can erase fax message(s) from the memory.					
2 Retrieve all faxes	Enter the number of a remote fax machine to receive stored fax message(s). (See page 10-5.)								
3 Erase fax from the memory	If you hear one long beep, you can erase fax message(s) from the memory.								
<b>97 Check the Receiving Status</b> <table border="1" data-bbox="229 861 506 916"> <tr> <td data-bbox="229 861 506 916">1 FAX</td> <td data-bbox="506 861 1064 916">You can check whether your MFC has received any faxes. If yes, you will hear one long beep. If no, you will hear three short beeps.</td> </tr> </table>	1 FAX	You can check whether your MFC has received any faxes. If yes, you will hear one long beep. If no, you will hear three short beeps.							
1 FAX	You can check whether your MFC has received any faxes. If yes, you will hear one long beep. If no, you will hear three short beeps.								
<b>98 Change Receive Mode</b> <table border="1" data-bbox="229 960 506 1069"> <tr> <td data-bbox="229 960 506 998">1 TAD: ANSWER MACH.</td> <td data-bbox="506 960 1064 1017" rowspan="3">If you hear one long beep, you can change the Receive Mode. If you hear three short beeps, you cannot change it.</td> </tr> <tr> <td data-bbox="229 998 506 1036">2 FAX/TEL</td> </tr> <tr> <td data-bbox="229 1036 506 1069">3 FAX ONLY</td> </tr> </table>	1 TAD: ANSWER MACH.	If you hear one long beep, you can change the Receive Mode. If you hear three short beeps, you cannot change it.	2 FAX/TEL	3 FAX ONLY					
1 TAD: ANSWER MACH.	If you hear one long beep, you can change the Receive Mode. If you hear three short beeps, you cannot change it.								
2 FAX/TEL									
3 FAX ONLY									
<b>90 Exit</b>	After a long beep, you can exit remote retrieval.								

## Retrieving Fax Messages

- 1 Dial your fax number.
- 2 When your MFC answers, immediately enter your Remote Retrieval Access Code (**1 5 9 \***). If you hear one long beep, you have messages.
- 3 As soon as you hear two short beeps, use the dial pad to press **9 6 2**.
- 4 Wait for the long beep, and then use the dial pad to enter the number of the remote fax machine where you want your fax messages forwarded (up to 20 digits) followed by **# #**.



You cannot use **\*** and **#** as dial numbers. However, if you want to store a pause, press **#**.

- 5 After you hear your MFC beep, hang up and wait.  
Your MFC calls the remote fax machine. The remote fax machine prints your fax messages.

## Changing Fax Forwarding Number

You can change the default setting of your fax forwarding number from a remote fax machine.

- 1 Dial your fax number.
- 2 When your MFC answers, immediately enter your Remote Retrieval Access Code (**1 5 9 \***). If you hear one long beep, you have messages.
- 3 When you hear two short beeps, use the dial pad to press **9 5 4**.
- 4 Wait for the long beep, and then use the dial pad to enter the new number of the remote fax machine where you want your fax messages forwarded (up to 20 digits) followed by **# #**.



You cannot use **\*** and **#** as dial numbers. However, if you want to store a pause, press **#**.

- 5 After you hear your MFC beep, hang up.

# 11 Printing Reports

## MFC Settings and Activity

---

Two reports require initial setup in the Menu table: Transmission Verification Report and Fax Activity Report. For initial setup:

Press **Menu/Set, 2, 4, 1.**

1. TRANSMISSION

—OR—

Press **Menu/Set, 2, 4, 2.**

2. ACT. INTERVAL

### Customizing the Transmission Verification Report

You can use the Transmission Verification Report as proof that you sent a fax. This report lists the time and date of transmission and whether the transmission was successful (OK). If you select **ON** or **ON+IMAGE**, the report will print for every fax you send.



When the feature is **OFF**, the report prints only when a transmission error prevented delivery (NG).

If you typically send multiple faxes to the same destinations, you may need more than the job numbers to know which faxes you must send again. Selecting **OFF+IMAGE** will print a portion of the fax's first page on the report to help you remember.

1 Press **Menu/Set, 2, 4, 1.**

1. TRANSMISSION

2 Press  to select **OFF**,

**OFF+IMAGE**, **ON** or **ON+IMAGE**,  
and then press **Menu/Set**.



3 Press **Stop/Exit**.

### Setting the Fax Activity Report Interval

You can set the machine to print activity reports at specific intervals (6, 12, 24 hours, 2, 4, or 7 days). If you set the interval to **OFF**, you can print the report by following the Steps in the previous section.

1 Press **Menu/Set, 2, 4, 2.**

2. ACT. INTERVAL

- 2 Press  or  to choose an interval, INTERVAL: OFF and then press **Menu/Set**.  
(If you choose 7 days, the LCD prompts you to choose the day at which to begin the 7-day countdown.)
- 3 Enter the time to begin printing in 24-hour format, and then press **Menu/Set**.  
(For example: enter 19:45 for 7:45 PM.)
- 4 Press **Stop/Exit**.

## Using the Reports Key



Five reports are available:

1.HELP LIST

Prints the Help List so you can see at-a-glance how to quickly program every menu selection.

2.AUTO DIAL

Lists names and numbers stored in One Touch and Speed Dial memory, in numerical order.

3.FAX ACTIVITY

Lists information about the last 200 incoming and outgoing faxes. TX means Transmit; RX means Receive.



4.TRANSMISSION

Prints a Transmission Verification Report for your last transmission.

5.USER SETTINGS

Lists settings for **GENERAL SETUP**, **SETUP RECEIVE**, **SETUP SEND**, **SETUP REPORTS**, and **TEL SERVICE**. The settings for **REMOTE FAX OPT** are included.

### To Print a Report

- 1 Press **Reports**.
- 2 Press  or  to select the report you want, and then press **Menu/Set**.

—OR—

Enter the number of the report you want to print. For example, press **1** to print the Help List.

# 12 Making Copies

## Basic Copy Operations

Your MFC allows you to make high-quality photocopies and transparencies. Copies can be in black and white or full color. Always make sure you have paper in the tray before making copies. Do not pull on the paper while copying is in progress.

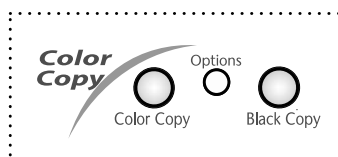

 Incoming faxes cannot be received on paper or into memory while the MFC is copying.

### Making a Single Copy

- 1 Place the original face down in the ADF.
- 2 Press **Black Copy** or **Color Copy**.  
(Do **NOT** pull on the paper while copying is in progress.)

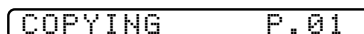
A rectangular digital display showing the text 'COPYING' on the left and 'P.01' on the right.

 To stop the copy process and release the original, press **Stop/Exit**.

### Making Multiple Copies

You can make multiple copies.

- 1 Place the original face down in the ADF.
- 2 Using the dial pad, enter the number of copies you want (up to 99).  
For example, press **3 8** for 38 copies.
- 3 Press **Black Copy** or **Color Copy**.



## Out of Memory Message

If the memory becomes full while you are making copies, the LCD shows a message:

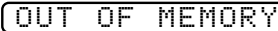

OUT OF MEMORY

If the **OUT OF MEMORY** message appears while you are scanning the *first* page of your original, press **Stop/Exit** to cancel. Clear some jobs from memory so you can continue. If you were scanning *subsequent* page(s), press **Black Copy** or **Color Copy** to print the scanned pages—**OR**—Press **Stop/Exit** to cancel.



To gain extra memory, you can turn off Fax Storage (see page 10-2).  
—**OR**—Print the faxes in memory (see page 6-6).

## Temporary Copy Settings

You can improve your copies by using the **Options** key. These settings are *temporary*, and the MFC returns to its default settings when you finish copying.

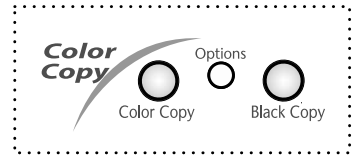

## Copying Using Multiple Settings

You can try different combinations of settings for the best results. After you finish your settings using the **Options** key, the LCD shows:



- Press  if you want to select additional settings.

—**OR**—

Press **Black Copy** or **Color Copy** if you are finished choosing settings.

## Using the Options Key

Use the **Options** key to set number of copies, paper type, paper size, brightness, enlargement/reduction ratio and special copy options **for the next copy only**.

Press Options	Menu Selections	Options	Factory Setting
 Options	OPT:#OF COPIES01	NO. OF COPIES:XX	01
	OPT:PAPER TYPE	PLAIN/INK JET/GLOSSY (4-COLOR or 3-COLOR)/ TRANSPARENCY	PLAIN
	OPT:PAPER SIZE	LETTER/LEGAL/A4/ POST CARD: 4" × 6"	LETTER
	OPT:QUALITY	NORMAL/BEST/FAST	NORMAL
	OPT:BRIGHTNESS	-■■■■■+	-■■■□□+
	OPT:ELG/RDC	50%/78% LGL>LTR/ 94% A4>LTR/100%/ 104% EXE>LTR/150%/ 200%/ZOOM	100%
	OPT:SPECIAL	OFF (1 IN 1)	OFF (1 IN 1)

### Paper Type

You can change the paper type setting for the next copy only.

- 1 Place the original face down in the ADF.
- 2 Use the dial pad to enter the number of copies you want (up to 99).
- 3 Press **Options** and press  to select **OPT:PAPER TYPE**, and then press **Menu/Set**.

- 4 Press  to select the type of paper you are using (**PLAIN**, **INKJET**, **GLOSSY** or **TRANSPARENCY**), and then press **Menu/Set**.

- 5 If you selected **GLOSSY**, press  to select **4-COLOR** or **3-COLOR**, and then press **Menu/Set**.





The print quality of black ink varies depending on the kind of glossy paper you are using. Black ink is used when you select **4-COLOR**. If the glossy paper you are using repels the black ink, select **3-COLOR**, which simulates black ink by combining the three ink colors.

- 6 Press **Black Copy** or **Color Copy**—**OR**—Press  for additional settings.

## Paper Size



You can change the paper size setting for the next copy only.

- 1 Place the original face down in the ADF.
- 2 Use the dial pad to enter the number of copies you want (up to 99).
- 3 Press **Options** and select **OPT:PAPER SIZE**, and then press **Menu/Set**.
- 4 Press  to select the size of paper you are using (**LETTER, LEGAL, A4** or **POST CARD: 4" × 6"**), and then press **Menu/Set**.
- 5 Press **Black Copy** or **Color Copy**—OR—Press  for additional settings.





## Copy Quality

You can change the copy quality setting (**NORMAL, BEST** or **FAST**).

<b>FAST:</b>	Fast copy speed and lowest ink consumption. Use FAST to save time (documents to be proof-read, large documents or many copies).
<b>NORMAL:</b>	Recommended mode for ordinary printouts. Good copy quality with adequate copy speed.
<b>BEST:</b>	Use this mode to copy precise images such as photographs. BEST uses the highest resolution and slowest speed.

- 1 Place the original face down in the ADF.
- 2 Use the dial pad to enter the number of copies you want (up to 99).
- 3 Press **Options** and select **OPT:QUALITY**, and then press **Menu/Set**.
- 4 Press  to select the copy quality (resolution), and then press **Menu/Set**.
- 5 Press **Black Copy** or **Color Copy**—OR—Press  for additional settings.

## Copy Brightness

- 1 Place the original face down in the ADF.
- 2 Use the dial pad to enter the number of copies you want (up to 99).
- 3 Press **Options** and press  to select **OPT: BRIGHTNESS**, and then press **Menu/Set**.  

- 4 Press  to make a lighter copy—OR—press  to make a darker copy, and then press **Set**.

- 5 Press **Black Copy** or **Color Copy**—OR—Press  for additional settings.

### Reducing and Enlarging Copies

- 1 Place the original face down in the ADF.
- 2 Use the dial pad to enter the number of copies you want (up to 99).
- 3 Press **Options** and press  to select **OPT:ELG/RDC**, and then press **Menu/Set**.

- 4 Press  to choose an enlargement or reduction ratio, and then press **Menu/Set**.

You can reduce to **50%**, **78% LGL>LTR** or **94% A4>LTR** of the original size.  
—OR—

You can enlarge to **104% EXE>LTR**, **150%** or **200%**.  
—OR—

For more choices select **ZOOM**, and then press **Menu/Set**. Use the dial pad to enter any percentage between **25%** and **400%**, and then press **Menu/Set**. For example, press **5 3** to enter 53%.

- 5 Press **Black Copy** or **Color Copy**—OR—Press  for additional settings.

### Selecting Fixed Reduction Ratios:

When selecting a reduction ratio, you will need to know the size of paper you registered in Menu 1-2 if you don't change the paper size setting using **Options**.





If you want to make a copy the same size as the original, you should choose a reduction of 93%. (For example, if you want to copy from letter to letter, you should choose a reduction of 93%.)

Original size is...	Paper size is...	Recommended reduction ratio is...
LETTER DOCUMENT	LETTER	93%
	LEGAL	100%
A4 DOCUMENT	LETTER	94%
LEGAL DOCUMENT	LETTER	78%
	LEGAL	93%

## Special Copy Option

You can save paper by copying two pages onto one page.

- 1 Place the original face down in the ADF.
- 2 Press **Options** and  to select **OPT: SPECIAL**, and then press **Menu/Set**.
- 3 Press  to select **2 IN 1** or **OFF (1 IN 1)**, and then press **Menu/Set**.
- 4 Press **Black Copy** or **Color Copy**—**OR**—Press  for additional settings.

### 2 in 1

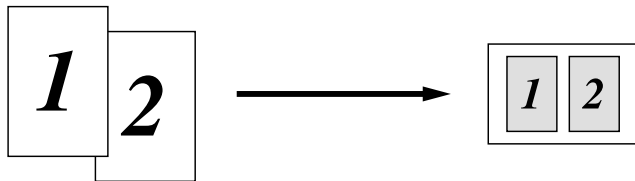

 2 in 1 copies are not available with:

- Multiple Copies
- Enlarge/Reduce
- GLOSSY Paper Type setting

 If 2 in 1 Copies are in color, you must use letter or A4 paper.

# Changing Default Copy Settings

Press **Menu/Set** and **3** to change default Copy mode settings. They will remain until you change them again by pressing **Menu/Set**.

By pressing a number, you can adjust the Quality, Color and Contrast copy settings shown in the following chart. Press  to scroll through the options for each setting, and then press **Menu/Set** to save your selection.

Press **Stop/Exit**—OR—Press  to select the next setting you want to change.

Press **Menu/Set** and **3**.

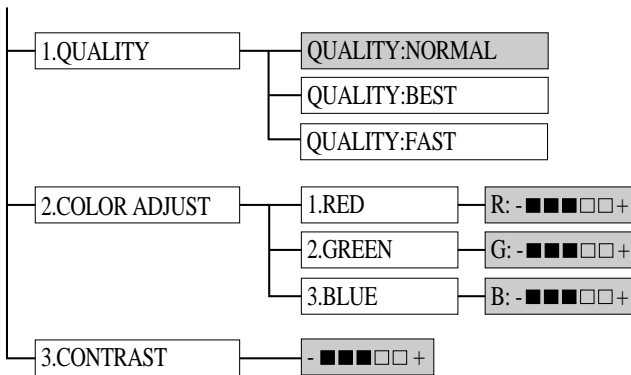

 is default

## Copy Quality

- 1 Press **Menu/Set**, **3**, **1**.
- 2 Press  to select the copy quality, and then press **Menu/Set**.
- 3 Press **Stop/Exit**.



1. QUALITY

QUALITY: NORMAL

QUALITY: BEST

QUALITY: FAST

## Color Adjustment

- 1 Press **Menu/Set**, **3**, **2**.
- 2 Press  to select **RED**, **GREEN** or **BLUE**, and then press **Menu/Set**.
- 3 Press  to make a darker copy, or press  to make a lighter copy, and then press **Menu/Set**.
- 4 Return to Step 2 to select the next color —**OR**— Press **Stop/Exit**.

2. COLOR ADJUST

Light Dark



R: - ■■■□□ +

G: - ■■■□□ +

B: - ■■■□□ +

## Copy Contrast

You can change the contrast to help an image look sharper and more vivid.

- 1 Press **Menu/Set**, **3**, **3**.
- 2 Press  to increase the contrast, or press  to decrease the contrast, and then press **Menu/Set**.
- 3 Press **Stop/Exit**.

- ■■■□□ +

## ***Legal Limitations***

---

Color reproductions of certain documents are illegal and may result in either criminal or civil liability. This memorandum is intended to be a guide rather than a complete listing of every possible prohibition. In case of doubt, we suggest that you check with counsel as to any particular questionable documents.

The following documents issued by the United States/Canadian Government or any of its Agencies may not be copied:

- Paper money
- Bonds or other certificates of indebtedness
- Certificates of Deposit
- Internal Revenue Stamps (canceled or uncanceled)
- Selective Service or draft papers
- Passports
- United States/Canadian Postage Stamps (canceled or uncanceled)
- Food Stamps
- Immigration Papers
- Checks or drafts drawn by Governmental agencies
- Identifying badges or insignias

Copyrighted works cannot be copied; however, sections of a copyrighted work can be copied for “fair use.” Multiple copies would indicate improper use.

Works of art should be considered the equivalent of copyrighted works.

Licenses and Certificates of Title to motor vehicles may not be copied under certain state/provincial laws.



# 13 Using the MFC as a Printer

## Features

---

The Multi-Function Center offers you many features you'll find in a high quality ink jet printer.

**Fast Printing Speed**—Using Draft mode, you can print up to 8 pages per minute in full color, and up to 10 pages per minute in black.

**Brilliant High Quality Output**—Printing at 2400 × 1200 dpi resolution on glossy paper gives you highest resolution output.

**Beautiful Elaborate Output**—You can utilize 2 in 1, watermark printing, True2Life technology and other features for making beautiful outputs.

**Low Running Cost**—Whenever you run out of a particular color ink, you'll replace only the cartridge that's empty.

**USB**—Universal Serial Bus Interface allows for fast communication with your computer.

**Straight Paper Path**—The MFC can use various types of paper: plain paper, Ink Jet Paper, glossy paper, transparencies, and envelopes. Using the appropriate paper reduces the occurrence of paper jams. For complete information about what kinds of paper to use with the MFC, please read Chapter 3 in this manual.

## Printer Driver

---

You can change the following printer settings when you print from your computer:

- Quality (Speed) /Media
- Color Matching
- Halftone
- Color Enhance/True2Life
- Fast Draft Mode
- Watermark
- Print Date & Time

## Choosing the Right Kind of Paper

---

To achieve high quality printing using your MFC, it's very important to select the right kind of paper. Be sure to read "About Paper" page 3-1 of Chapter 3 in this manual before selecting and purchasing paper for the MFC.

## How to print your document

---

When the MFC receives data from your computer, it begins printing by picking up paper from the paper tray. The paper tray can feed many types of paper and envelopes.

- 1 From your computer select the Print command.  
If your computer is also connected to any other printers, select **Brother MFC-3200C** as your printer driver from the Print or Print Settings menu in your software application, and then click on OK to begin printing.
- 2 Your computer sends a print command and data to the MFC.  
The LCD shows **RECEIVING DATA**.
- 3 When the MFC finishes printing all the data, the LCD show the date and time.



You can select the paper source, paper size, and orientation in your application software.

## Simultaneous Printing/Fax

---

Your MFC can print data from your computer while sending or receiving a fax, or while scanning information into the computer. However, when the MFC is copying or receiving a fax on paper, it pauses the PC printing operation, and resumes when copying or fax receiving is complete. Fax sending will continue during PC printing.

## Printer Operation Key

---

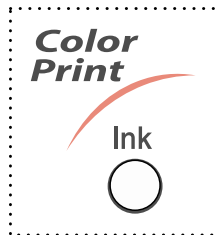

### Ink Key

When you press **Ink**, the LCD shows:

1. CLEANING

If you are having trouble with one of the ink colors, you may need to clean the print head. (See page 23-10.)

2. REPLACE INK

If you got an error message **NEAR EMPTY** or **INK EMPTY**, you will need to replace the ink cartridge for the appropriate color. (See *Error Messages*, page 23-1.)

### Clearing Data from the Memory

If the LCD shows **REMAINED DATA**, you can clear data remaining in the printer memory by pressing **Stop/Exit**.

## Checking the Print Quality

---

If you want to check the print quality and find out how to improve it, See *How to Improve Print Quality*, page 23-10.

# 14 Printer Driver Settings

(For Windows® Only)

## Using the Brother MFC-3200C Printer Driver

A Printer driver is software that translates data from the format used by a computer into the format required by a particular printer, using a printer command language or page description language.

The printer drivers are on the supplied CD-ROM. The latest printer driver can also be downloaded from the Brother Solutions Center at <http://solutions.brother.com>.

## How to Access the Printer Driver Settings

- 1 Select **Print** from the **File** menu in your application software.
- 2 Select **Brother MFC-3200C** as your printer and click **Properties**. The **Brother MFC-3200C on BRUSB: Properties** dialog box will appear.

**Note** The way you access the printer driver settings depends on your operating system and software applications.

**Note** The screens shown in this section are from Windows® 98 Second Edition. The screens on your Computer may vary depending on your Windows Operating System.

### If You Are Using Windows® XP

Brother offers both a Windows® Logo Tested (WHQL) driver and a Brother Native Driver on the CD-ROM. The Windows® Logo Tested Driver is automatically installed when you follow the installation steps in the Quick Setup Guide, pages 17 to 20. The Brother Native driver offers some features that are not available with the Windows® Logo Tested Driver. The features available on the Brother Native driver can vary by model. Please see the README.WRI file on the CD-ROM or the visit us at <http://solutions.brother.com> for details on these features. You must follow the steps in the Quick Setup Guide, pages 17 to 20 before you can proceed to the installation procedure for the Brother Native Driver.

# Features in the Brother Native Driver

The following section describes the Brother Native Driver features and selections available for Windows®.

## Paper Tab

The paper tab screen allows you to set up the Paper Size, Paper Source, Paper Thickness, Orientation, Scaling, and Copy/Page Order.

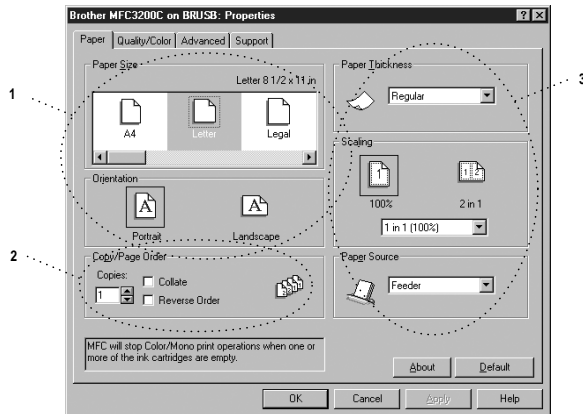

Select the **Apply** button to apply your selected settings.

To return to the default settings, click the **Default** button, then click the **Apply** button.

- 1 Select the Paper Size and Orientation.
- 2 Select number of Copies and Page Order.
- 3 Select Paper Thickness, Scaling and Paper Source.

## Paper Size

The paper size selection provides a large selection of standard paper sizes or you can even create custom sizes ranging from 3.5 × 5” to 8.5 × 14”. To select the paper size you want to use click the icon.

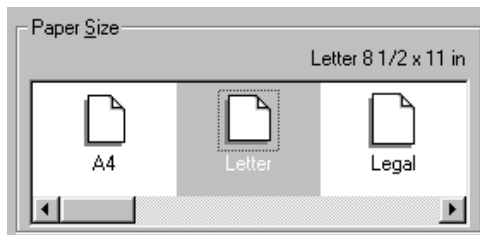

## Orientation

Orientation selects the position of how your document will be printed (Portrait or Landscape).



## Copy/Page Order

### Copies

The copies selection sets the number of copies that will be printed (1 to 999).

### Collate

With the collate check box selected, one complete copy of your document will be printed and then repeated for the number of copies you selected. If the collate check box is not selected, then each page will be printed for all the copies selected before the next page in the document is printed.

### Reverse Order

Reverse Order prints the pages of your document in the opposite order.

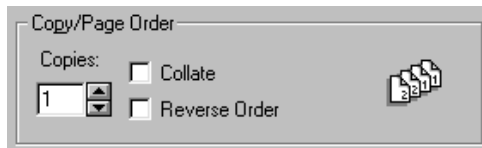

## Paper Thickness

Depending on the thickness of the paper you are using, you can improve the quality of your output by selecting the correct thickness. This setting provides the best positioning of the paper for printing. For example if you were printing on thin paper, you would select **Thin** in the Paper Thickness selection to achieve the best paper handling and improved output for that paper type.

**Regular**

**Thin**

**Thick**

**Thicker**

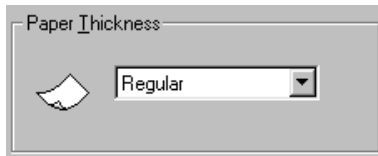

## Scaling

The Scaling feature reduces or enlarges your document from 50% to 200%. From the pull-down box you can select from the preset settings or a free setting. You can also select 2 in 1 printing for printing two pages on one sheet of paper.



For Windows® 2000 Professional, you can also select 4 in 1 printing.

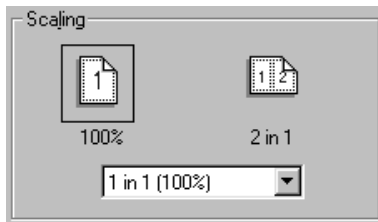

## Paper Source

The Paper Source pull-down allows you to choose the source of the media you are using.

**Feeder (Paper Tray)**

**Manual Feed**

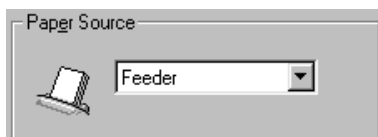

## Quality/Color Tab

The Quality/Color tab screen provides Quality, Media type, Document type, Color/Mono settings, Bi-directional Printing settings and Fast Draft Mode. All of these selections are designed to offer the best quality output for your document needs.

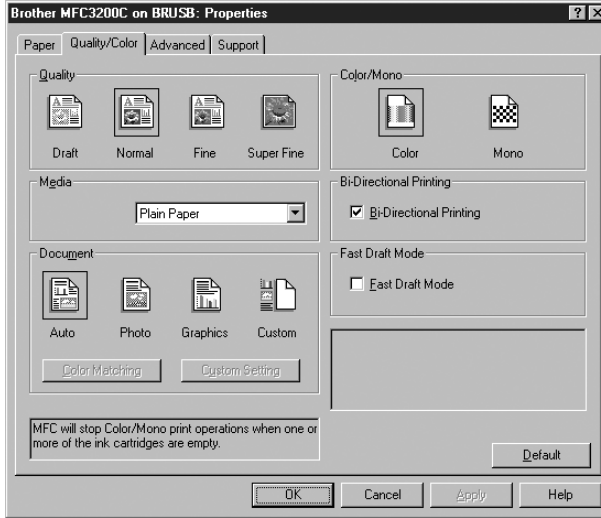

Select the **Apply** button to apply your selected settings.

To return to the default settings, click the **Default** button, then click the **Apply** button.

### Quality

The quality selection allows you to choose the print resolution you want your document. Print quality and speed are related. The higher the quality the longer it will take to print the document. The quality selections available vary depending on the media selection.

- **Draft:** The fastest print mode and the lowest ink consumption. Use this mode to print large volume documents or a document for proofing.
- **Normal:** Recommended for ordinary printouts.
- **Fine:** Better print quality than normal mode and faster print speed than Super Fine.
- **Super Fine:** Use this mode to print precise images such as photographs. Since the print data is much larger than normal mode, the processing time, data transfer time and print time will be longer.



## Media

To achieve the best print results, the media being printed on should be selected in the driver. The MFC changes the way it places dots, depending on the selected media type.

Paper Type	Recommended Print Quality Selection
Plain Paper	Normal
Inkjet Paper	Fine
Glossy Paper (4 color)	Super Fine
Glossy Paper (3 color)	Super Fine
Transparencies	Fine
Transparencies (mirror)	Fine



The print quality of black ink varies depending on the kind of glossy paper you are using. Black ink is used when you select **Glossy Paper (4 color)**. If the glossy paper you are using repels the black ink, select **Glossy Paper (3 color)**, which simulates black ink by combining the three ink colors.

## Document

The printer driver will select the most suitable color matching method, depending on your document type. Generally, text and business graphics are printed vividly and photographic images are printed softly.

- **Auto:** The printer driver automatically selects the document type.
- **Photo:** Select this mode for photographic images.
- **Graphics:** Select this mode for documents that contain text or business graphics (charts or clip art).
- **Custom:** If you want to select the color matching method and halftone method, manually select this mode.

## Color Matching

You can select the color matching method manually. Select the best one for your document.

### ■ Match Monitor

Suitable for photographic images. Color is adjusted to get the closest color match to the PC monitor.

### ■ Vivid Color

Suitable for business graphics such as charts, graphs, and text. The color is adjusted to give more vivid color.

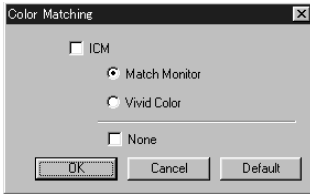

(For Windows® 98/98SE/Me user's)

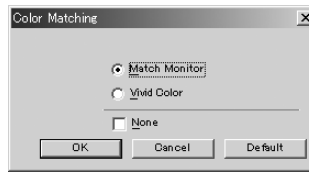

(For Windows® 2000 Professional user's)

## Custom Setting

You can customize your settings by selecting the type of Halftone or Color Enhance/True2Life.

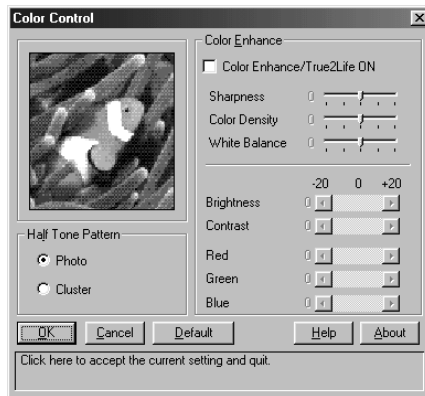

## Halftone Pattern

The MFC can use several methods to arrange where to place dots to express halftones. There are some predefined patterns used to place dots and you can select which one is used for your document. Select the appropriate method.

### ■ Photo

This method creates smooth halftones so that this is suitable for photographic images. It takes more time to process data, but this can express more levels of halftones and creates more natural images.

### ■ **Cluster**

This is suitable for business graphics such as charts, graphs and drawings, since this creates more sharp printouts. Moreover, the processing time is shorter.

### **Color Enhance**

Selecting Color Enhance/True2Life ON enables the True2Life feature. This feature analyzes your image to improve quality sharpness, white balance and color density. This process may take several minutes depending on the size of the image, the speed and RAM memory of your computer.

### ■ **Color Enhance/True2Life ON**

Adjusts the color in the image for better print quality. Print time will be longer with True2Life set to ON.

### ■ **Sharpness**

This setting enhances the detail of an image. This is similar to adjusting the fine focus on a camera. If the focus is off a little you will not be able to clearly see the fine details of an image.

### ■ **Color Density**

This adjusts the total amount of color in the image. You can increase or decrease the amount of color in an image to improve a picture which may appear washed out or weak.

### ■ **White Balance**

This adjusts the hue of the white sections of an image. Lighting, camera settings and other influences will effect the appearance of white. The white parts of a picture may appear to be slightly pink, yellow or some other color. By using this adjustment you can correct this effect and bring the white sections back to pure white.

### ■ **Brightness**

Change the brightness of the whole image lighter or darker. Moving the scroll bar to the left makes your image darker and moving the scroll bar to the right makes your image lighter.

### ■ **Contrast**

Change the contrast of an image. Darker sections will be more dark and lighter sections will be more light as you increase the contrast. Increase the contrast when you want an image to be clearer. Decrease the contrast when you want an image to be more subdued.

### ■ **Red**

Increase the intensity of the Red color to add red to the whole image.

### ■ **Green**

Increase the intensity of the Green color to add green to the whole image.

### ■ **Blue**

Increase the intensity of the Blue color to add blue to the whole image.

## Color/Mono

This selection allows a color document to be printed in mono only.

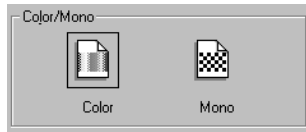

## Bi-Directional Printing

When Bi-Directional Printing is selected, the print head prints in both directions and offers faster print speeds. When not selected the print head prints in one direction only and provides higher print quality.

## Fast Draft Mode

You can print much more quickly than mono draft mode, by using both black and cyan ink.

## Advanced Tab

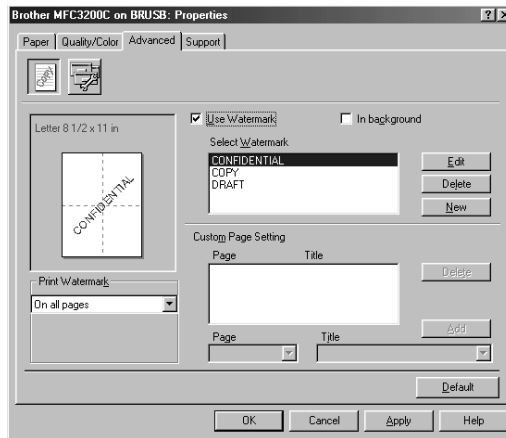

Select the **Apply** button to apply your selected settings.

To return to the default settings, click the **Default** button, then click the **Apply** button.

Change the tab settings by selecting one of the following icons:

- Watermark
- Device Options

## Watermark

To place a logo or text into your document as a Watermark, use a bitmap file or text you created as your source file or select one of the preset Watermarks.

## Print Watermark

The Print Watermark feature offers the following print choices:

- On all pages
- On first page only
- From second page
- Custom

### In background

With the In background feature checked the Watermark will print on the page behind your document. If this feature is not checked then the Watermark will print on top of your document.

## Watermark Style

You can change the Watermark's size and the position on the page by selecting the Watermark, and then clicking the **Edit** button. If you want to add a new Watermark, click the **New** button, and then select Text or Bitmap in the Watermark Style.

### Watermark Text

Enter your Watermark text into the Text Box, and then select the Font, Size, Color and Style.

### Watermark Bitmap

Enter the file name and location of your bitmap image in the File box or Browse for the file location. You can also set the scaling size of the image.

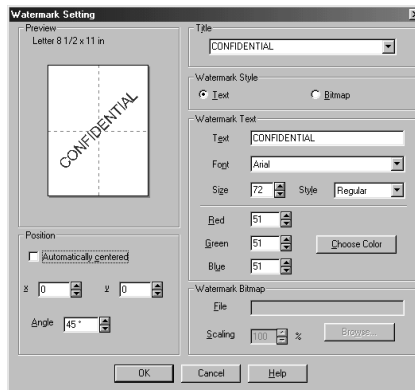

### Position

The position settings offer controls for where the Watermark is positioned on the page.

## Device Options

Set the Print Date & Time as the Printer Function:

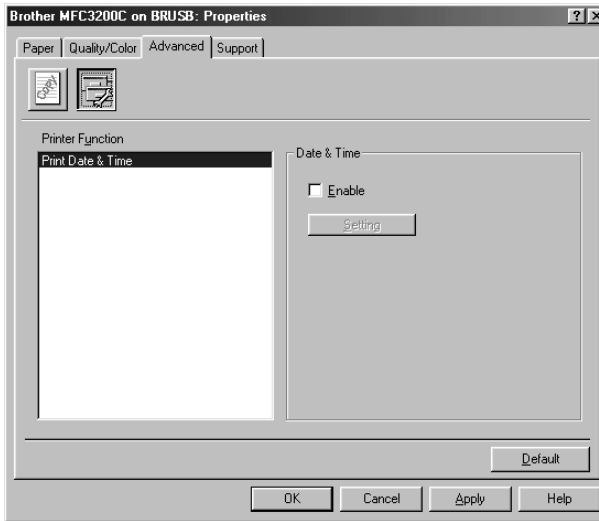

## Print Date & Time

When enabled the Print Date and Time feature will automatically print the date and time from your computer's system clock on your document.

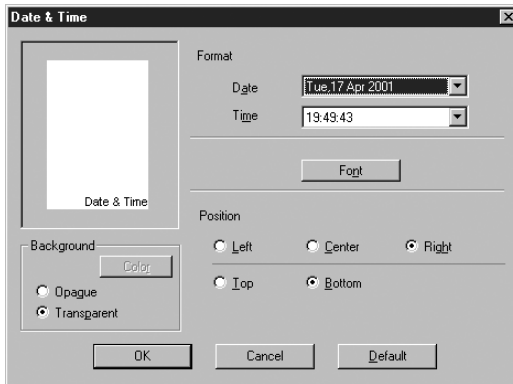

Click the Setting button to change the Date and Time Format, Position and Font. To include a background with the Date and Time, select Opaque. When Opaque is selected, you can click on the Color button to change the color of the Date and Time background.



The Date and Time indicated in the selection box shows the format that will be printed. The actual Date and Time printed on your document is automatically retrieved from the settings of your computer.

## Support

The Support Tab provides driver version information and setting information. In addition there are links to the Brother Solutions Center and Driver Update Web sites.

Click the Support tab to display the following screen:

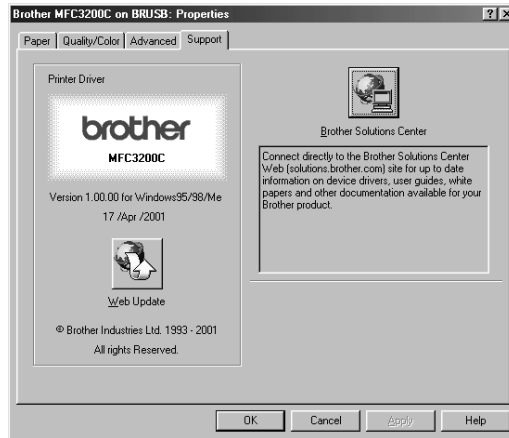

Select the **Apply** button to apply your selected settings.

To return to the default settings, click the **Default** button, then click the **Apply** button.

### Web Update

Web Update checks the Brother web site for updated drivers, and then it automatically downloads and updates the printer driver on your computer.

### Brother Solutions Center

The Brother Solutions Center is a Web site offering information about your Brother product including FAQs, User Guides, Driver updates and Tips for using your machine.

# Features in the Printer Uni-Driver (WHQL) (For Windows® XP)

---

The Windows® XP printer driver utilizes Microsoft's uni-driver architecture. The following section describes the driver features and selections available for Windows® XP.

## Layout Tab

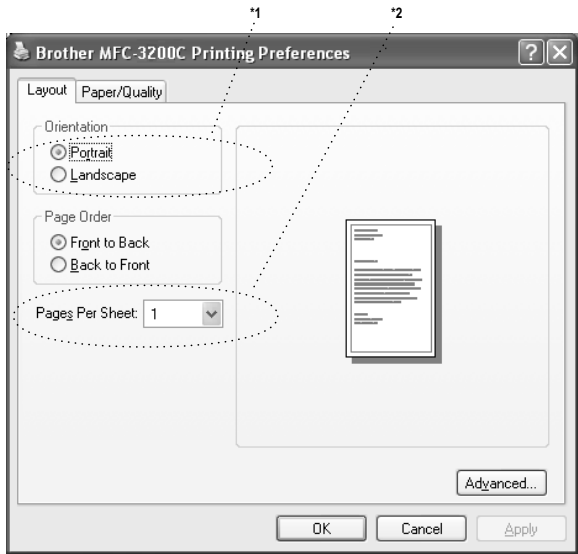

### \*1 Orientation

Select the Orientation, which is how your document will be positioned on the paper (Portrait or Landscape).



Portrait

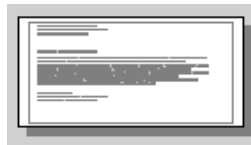

Landscape



## \*2 Pages Per Sheet

You can select 1, 2, 4, 6, 9 or 16 pages to be printed on one sheet of paper. The image of each page will be reduced as needed to fit on the paper.



2 in 1



4 in 1

## Paper/Quality Tab

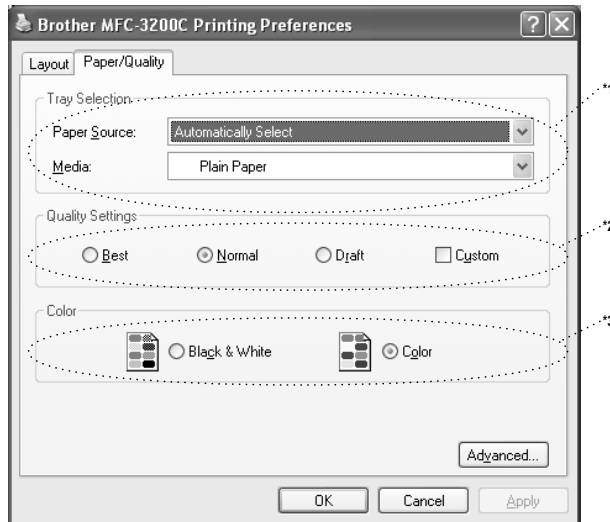

## \*1 Tray Selection

### ■ Paper Source

The machine feeds subsequent pages automatically even if you select either **Automatically Select** or **Feeder**.

### ■ Media

To achieve the best print results, the media being printed on should be selected in the driver. The MFC changes the way it places dots, depending on the selected media type.

Paper Type	Recommended Print Quality Selection
Plain Paper	Normal
Inkjet Paper	Fine
Glossy Paper (4 color)	Super Fine
Glossy Paper (3 color)	Super Fine
Transparencies	Fine
Transparencies (mirror)	Fine



The print quality of black ink varies depending on the kind of glossy paper you are using. Black ink is used when you select **Glossy Paper (4 color)**. If the glossy paper you are using repels the black ink, select **Glossy Paper (3 color)**, which simulates black ink by combining the three ink colors.

## \*2 Quality Settings

You can select from the predefined quality settings for your document. If you want to check or access additional selections for the print quality, refer to the **Print Quality** in the **Advanced Options**.

## \*3 Color

This selection allows a color document to be printed in **Black & White** only.



## Advanced Options

Click the **Advanced...** button in the Layout tab or Paper/Quality tab to access the screen below:

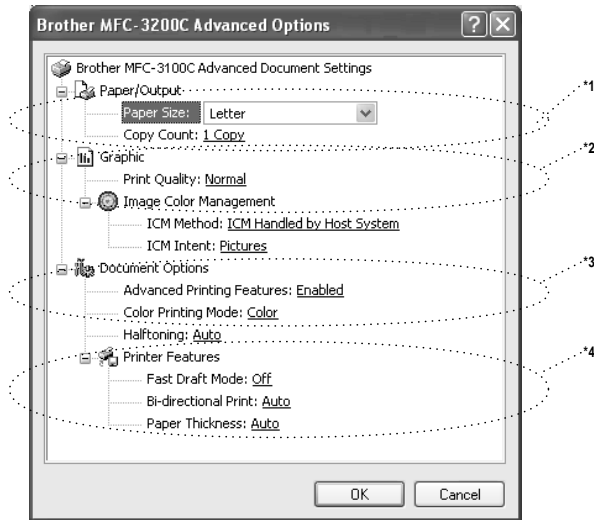

### \*1 Paper /Output

*Paper Size* - Select the paper size of the document you are printing. This size should be the same as the paper size that is set in your application software.

*Copy Count* - Type the number of copies you want.

## \*2 Graphic

*Print Quality* - The quality selection allows you to choose the print resolution you want for your document. Print quality and speed are related. The higher the quality the longer it will take to print the document. The quality selections available vary depending on the media selection.

**Draft:** The fastest print mode and the lowest ink consumption. Use this mode to print large volume documents or a document for proofing.

**Normal:** Recommended for ordinary printouts.

**Fine:** Better print quality than normal mode and faster print speed than Super Fine.

**Super Fine:** Use this mode to print precise images such as photographs. Since the print data is much larger than normal mode, the processing time, data transfer time and print time will be longer.



The print quality that can be selected depends on the media you selected. You can select the following quality settings for each media.

Plain Paper: Draft, Normal, Fine, Super Fine

Inkjet Paper: Normal, Fine, Super Fine

Glossy Paper (4 color): Fine, Super Fine

Glossy Paper (3 color): Fine, Super Fine

Transparency: Fine, Super Fine

Transparency (mirror): Fine, Super Fine

## \*3 Document Options

*Halftone Pattern* - The MFC can use several methods of arranging where dots are placed on the paper to express halftones. You can select which predefined pattern is used for your document.

### **Photo**

This method creates smooth halftones suitable for photographic images. It takes more time to process the data, but this selection can express more levels of halftones and creates more natural images.

### **Cluster**

This is suitable for business graphics such as charts, graphs and drawings. This selection creates sharper printouts and has a shorter processing time.

### **Auto**

If you selected Plain Paper and the print resolution is less than Fine Quality, Auto works as Cluster. If you select another media type or a higher resolution, Auto works as Photo.

## **\*4 Printer Features**

*Fast Draft Mode* - This mode prints using both black and cyan ink offering a faster print speed than mono draft mode.

*Bi-directional Print* - When Bi-Directional Print is set to ON, the print head prints in both directions and offers faster print speeds. When OFF is selected, the print head prints in one direction only and provides higher print quality. If you selected Plain Paper, Auto works in Bi-Directional Print mode.

*Paper Thickness* - Depending on the thickness of the paper you are using, you can improve the quality of your output by selecting the correct thickness. This setting provides the best positioning of the paper for printing. For example if you were printing on thin paper, you would select **Thin** in the Paper Thickness selection to achieve the best paper handling and improved output for that paper type.

**Regular**

**Thin**

**Thick**

**Thicker**

**Auto**

If you selected Envelopes in the Print Size, Auto works as Thicker. If you select any other print size, Auto works as Regular.

# 15 Using the Windows®-Based Brother MFL-Pro Control Center (For Windows® 98/98SE/Me and 2000 Professional)

## Brother MFL-Pro Control Center

---

 If you are using Windows® 2000 Professional, we recommend that you are logged on as an administrator.

The Brother Control Center is a software utility that pops up on the PC screen whenever paper is placed in the automatic document feeder. This allows you to quite easily, with very few mouse clicks, access the most frequently used scanning applications. Using the Control Center eliminates the need to manually launch the specific applications.

The Brother Control Center provides three categories of functions:

- 1 Scan directly to a file, E-mail, word processor or graphic application of choice
- 2 Copy operations
- 3 PC Faxing using the Brother MFL Pro PC Fax software

MFC-3200C



## AutoLoad the Brother Control Center

The Control Center is initially configured to automatically load each time Windows® is started. When the Control Center is loaded, the Control



Center  icon will appear in the task bar. If you don't want the Control Center to load automatically, you can turn off AutoLoad.



If the Control Center  icon does not appear in your task bar, you will have to launch this software.

From the **Start** menu, select **Programs, PaperPort**, and then double-click **Brother SmartUI POPUP**.

## How to Turn Off AutoLoad

- 1 Left click the Control Center  icon and click **Show**.
- 2 When the Control Center icon appears, left click on the Smart Click  Control Center button. A dialogue box with a check box labeled “AutoLoad Pop-up” will appear:

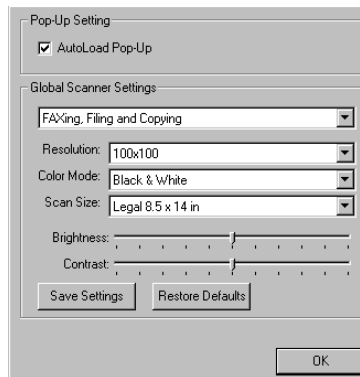

- 3 Uncheck the AutoLoad Pop-Up option.

# Brother Control Center Features

## Auto Configuration

During installation the Control Center will check your system to set up the default applications for E-mail, word processing and the graphics viewer/editor.

For example, if you are using Outlook as your default E-mail application, the Control Center will create a link and a scanning application button for Outlook.

You can change a default application Right-click the appropriate Control Center button to display *Configurations* and then click it. Select a different application.

For example, you can change a scan button from MS Word Pad

 to MS Word  by changing the application that is listed for the Word Processor.



## Scanning Operations

*Scan to File*—allows you to scan directly to a disk file with two mouse clicks. You can change the file type and destination directory and file name, as needed.

*Scan to E-mail*—enables you, with just two mouse clicks, to scan a picture or text document directly into an E-mail application as a standard attachment. You have the option of selecting the file type and resolution for the attachment.

*Scan to Word Processor*—enables you to scan a text document, run ScanSoft TextBridge OCR and insert the text original (not graphic image) into a word processing file with just two mouse clicks. You have the option of selecting the destination word processing program, such as Word Pad, MS Word, Word Perfect, etc.

*Scan to Graphic Application*—allows you to scan an image directly into any graphic viewer/editor application. You can select the destination application, such as Microsoft Paint or Corel PhotoPaint.



## Copy Operations

*Copy*—allows you to use the PC and any Windows® printer driver for enhanced copy functions. You can scan the page on the Brother MFC and print the copies using any of the features of the Brother MFC printer driver—**OR**—you can direct the copy output to any standard Windows® printer driver installed on the PC.

## PC Fax Operation

*Send a Fax*—allows you to scan a picture or text original and automatically send the image as a fax from the PC using the Brother PC-FAX software.

## Scanner Settings for Scan, Copy and PC Fax Buttons

When the Pop-Up screen is displayed, you can access the Scanner Settings window.

Click the Smart Click  icon at the top right of the Brother Control Center screen—**OR**—Click the **Modify Settings...** button on any of the Configuration screens.

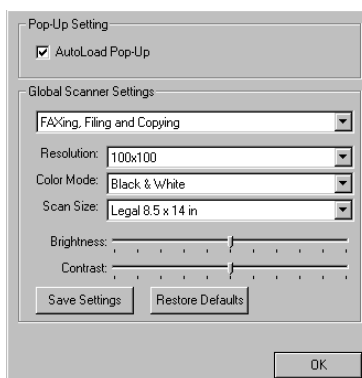

## Global Settings

*AutoLoad Pop-Up*—Click this checkbox if you want Brother MFL Control Center to load when you boot your computer.

## Setting Up the Scanner Configurations

The Pop-Up application stores eight different scanning modes. Each time you scan an original, you will choose the most appropriate scanning mode from the following:

*Faxing, Filing and Copying*  
*Text for OCR*  
*Photos*  
*Photos (High Quality)*  
*Photos (Quick Scan)*  
*Custom*  
*Draft Copy*  
*Fine Copy*

Each mode has its own set of stored settings. You can keep the factory default settings or change them at any time:

*Resolution*—From the pull-down list, select the scanning resolution you most frequently use.  
*Color Mode*—From the pull-down list, select  
*Scan Size*—From the pull-down list, select  
*Brightness*—Slide the adjuster from 0% to 100%  
*Contrast*—Slide the adjuster from 0% to 100%

Click **OK** to save your changes. If you make a mistake or later decide to return to the original default setting, just click the **Restore Defaults** button when the scanning mode is displayed.

## To Access the Scanner Configurations Screen:

- 1 Place the original in the ADF.
- 2 Right-click the appropriate Control Center button to display *Configurations...*, then click it. Click the **Modify Settings** button. The configuration screen for the **Control Center** button will appear.
- 3 To save your settings, press the **OK** button—**OR**—To return to the factory default settings, press the **Restore Defaults** button.

## Perform an Operation from the Control Center Screen

If you see this screen it means you left-clicked a button in the Control Center window without first placing an original in the ADF.

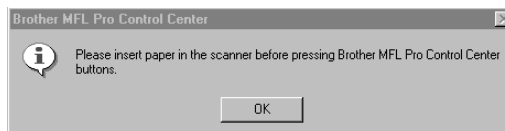

Place the original in the Brother machine's ADF, then click **OK** to return to the Control Center screen.

# Scan to File

---



## Scanner Settings

From the pull-down list, select the scanning mode that is appropriate for the type of file: Faxing, Filing and Copying; Text for OCR; Photos; Photos (High Quality); Photos (Quick Scan); Custom; Draft Copy or Fine Copy.

To change any of the settings for that mode, click the **Modify Settings...** button.

## Destination Folder

*PaperPort Folder*—Select this checkbox to scan the original into your PaperPort folder.

*Other Folder*—Select this checkbox, to scan the original as another file type and/or into another directory/folder.

*File*—If you selected Other Folder, from the pull-down list select the type of file:

- PaperPort Files (\*.MAX)
- Self Viewing Files (\*.EXE)
- PaperPort 5.0 Files (\*.MAX)
- PaperPort 4.0 Files (\*.MAX)
- PaperPort 3.0 Files (\*.MAX)
- Windows Bitmap (\*.BMP)
- PC Paintbrush (\*.PCX)
- Multi-page PCX (\*.DCX)
- JPEG Image Files (\*.JPG)
- TIFF-Uncompressed (\*.TIF)
- TIFF Group 4 (\*.TIF)
- TIFF Class F (\*.TIF)
- Multi-Page TIFF-Uncompressed (\*.TIF)
- Multi-Page TIFF Group 4 (\*.TIF)
- Multi-Page TIFF Class F (\*.TIF)
- PDF Files (\*.PDF)
- Portable Network Graphics (\*.PNG)
- FlashPix (\*.FPX)
- HFX Fax Files (\*.HFX)

To Search your system for the directory and folder you want, click the **Browse...** button. Click **OK** to save your settings.

## Scan to E-mail

---



## Scanner Settings

From the pull-down list, select the scanning mode that is appropriate for the type of file: Faxing, Filing and Copying; Text for OCR; Photos; Photos (High Quality); Photos (Quick Scan); Custom; Draft Copy or Fine Copy.

To change any of the settings for that mode, click the **Modify Settings...** button.

## E-mail Application

*E-mail Package*—From the pull-down list, select your E-mail application.

*E-mail Settings*—Click the **EMail Settings...** button to set up links.

The Links Preferences window will appear:

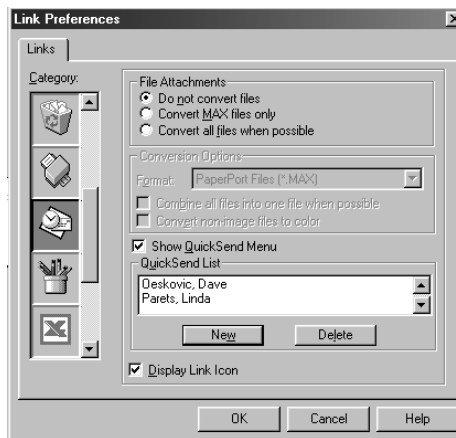

## File Attachments

*Do not convert files*—Click this checkbox if you do not want to change the file type of attachments. The Conversion Options will not be available (grayed).

*Convert MAX files only*—Click this checkbox if you want to convert only attachments that are PaperPort files.

*Convert all files when possible*—Click this checkbox if you want to change the file type of all attachments.

## Conversion Options

### Format

*Combine all files into one file when possible*—Click this checkbox to combine all files of the same type into one file.

*Convert non-image files to color*—Click this checkbox to convert all files that have been processed through OCR to color.

### Show QuickSend Menu

Click this checkbox if you want the Select QuickSend Recipient window to be displayed when you choose Scan to E-mail. This feature works only with MAPI type E-mail applications, such as Microsoft Exchange, Microsoft Outlook and Eudora.

### QuickSend List

You can create a list of Email names and addresses for quick selection.

Click the **New** button to add a name(s) to your QuickSend list. Your Email phone book listing is displayed, so you can select stored names or create new ones:

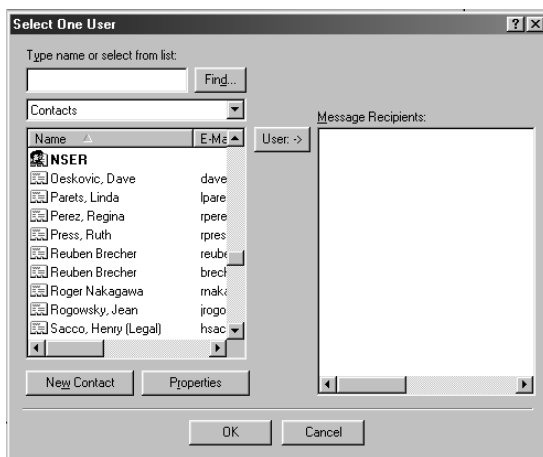

Highlight the name(s) you want to add to your list, click the **User** button, then click **OK** to return to the Link Preference window.

From the Link Preference window, you can remove a name from the QuickSend list, highlight the name and clicking the **Delete** button.

# Scan to Word Processor

---



## Scanner Settings

From the pull-down list, select the scanning mode that is appropriate for the type of file: Faxing, Filing and Copying; Text for OCR; Photos; Photos (High Quality); Photos (Quick Scan); Custom; Draft Copy or Fine Copy.

To change any of the settings for that mode, click the **Modify Settings...** button.

## Word Processor

*Word Processor*—From the pull-down list, select the word processor you want to use.

Click the **Link Settings...** button to display a screen to set up a link to the version of OCR and document format that you want to use:

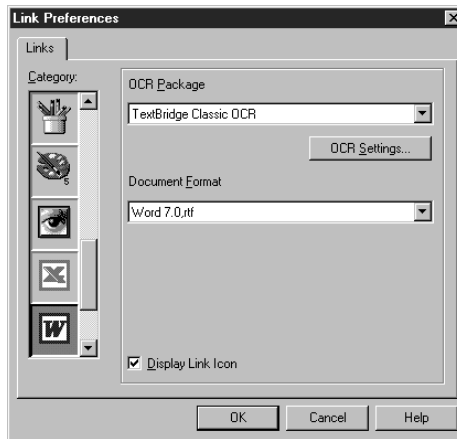

*OCR Package*—From the pull-down list, select *TextBridge Classic OCR* if you want to use the OCR package that was installed with the Brother software.

Click the **OCR Settings...** button to choose how the OCR application will read the pages you scan into your word processor application.

The Preferences window will appear:

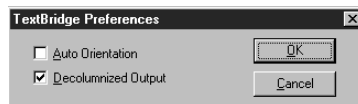

Select your setting and click **OK**.

- *Auto Orientation*—Check this checkbox if you want your word processor application to read the page as it is set up.
- *Decolumnized Output*—Check this checkbox if you want your word processor application to read across the entire page from left to right.
- *Document Format*—From the pull-down list, select the file format you want to use for your word processor or text documents.



# User Defined Button

---

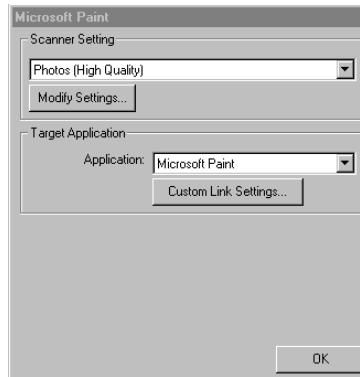

## Scanner Settings

From the pull-down list, select the scanning mode that is appropriate for the type of file: Faxing, Filing and Copying; Text for OCR; Photos; Photos (High Quality); Photos (Quick Scan); Custom; Draft Copy or Fine Copy.

To change any of the settings for that mode, click the **Modify Settings...** button.

## Target Application

*Application*—From the pull-down list, select the application you want to add to this Pop-Up screen.

Click the **Custom Link Settings...** button to set up links for your user-defined application.

# Copy

---

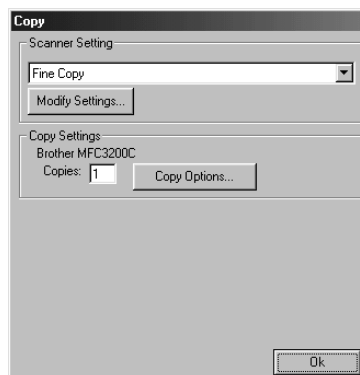

## Scanner Settings

From the pull-down list, select the scanning mode that is appropriate for the type of file: Faxing, Filing and Copying; Text for OCR; Photos; Photos (High Quality); Photos (Quick Scan); Custom; Draft Copy or Fine Copy.

To change any of the settings for that mode, click the **Modify Settings...** button.

## Copy Settings

Brother MFC-3200C

*Copies*—Enter the number of copies you want to print.

To change the copy options, click the **Copy Options...** button.

Click the **OK** button to save your Copy settings.

## Send a Fax

---



## Scanner Settings

From the pull-down list, select the scanning mode that is appropriate for the type of file: Faxing, Filing and Copying; Text for OCR; Photos; Photos (High Quality); Photos (Quick Scan); Custom; Draft Copy or Fine Copy.

To change any of the settings for that mode, click the **Modify Settings...** button.

## FAX Settings

*Brother MFL Pro Fax*

*FAX Resolution—Fine (200 × 200)*

To change the fax options, click the **FAX Options...** button.

Click the **OK** button when you are ready to save your FAX settings.

The MFL Pro Fax on COM1 Properties screen appears:

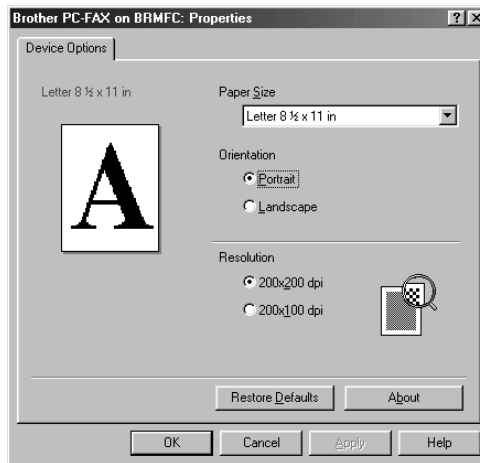

Select the *Paper Size and Orientation* (Portrait or Landscape) and click **OK**.

To return to the factory default settings, click the **Restore Defaults** button.

# 16 Using the Windows<sup>®</sup>-Based Brother SmartUI Control Center (For Windows<sup>®</sup> XP)

## Brother SmartUI Control Center

---

The Brother Control Center is a software utility that allows you to quite easily, with very few mouse clicks, access the most frequently used scanning applications. Using the Control Center eliminates the need to manually launch the specific applications.

The Brother Control Center provides four categories of operations:

- 1 Scan directly to a file, E-mail, word processor or graphic application of your choice.
- 2 Enhanced copy functions, such as Nine/Four/Two or One on One Copying. (NOTE: The number of copy buttons may vary depending on which model MFC you purchased.)
- 3 PC Faxing using the Brother PC Fax software.
- 4 Custom buttons allow you to configure a button to meet your own application requirements. (NOTE: The number of Custom buttons may vary depending on which model MFC you have purchased.)

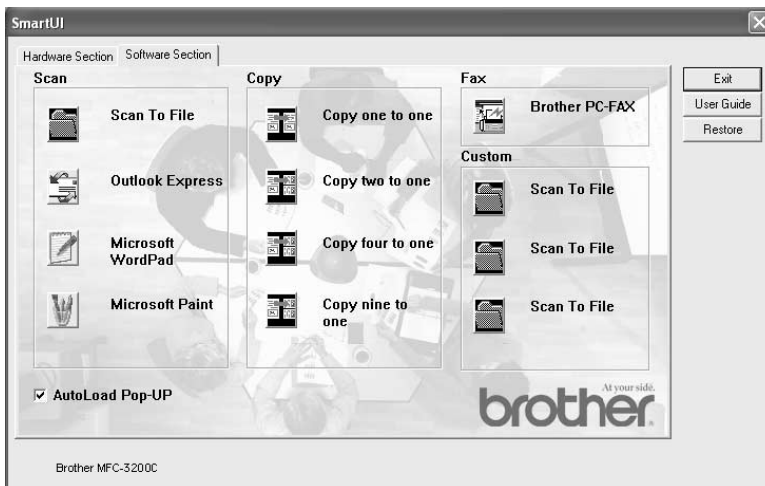

In the Task Tray right click on the Control Center  icon and select Show to have access to the Brother SmartUI Control Center window.

## AutoLoad the Brother Control Center

The Control Center is initially configured to automatically load each time Windows® is started. When the Control Center is loaded the Control Center  icon will appear in the task bar. If you don't want the Control Center to load automatically, you can turn AutoLoad off.

## How to Turn Off Auto Load

- 1 Right click the Control Center  icon in the Task Tray and select **Show**.
- 2 The main SmartUI Control Center window appears. Please look at the bottom of the window for a check box labeled “AutoLoad Pop-up”.

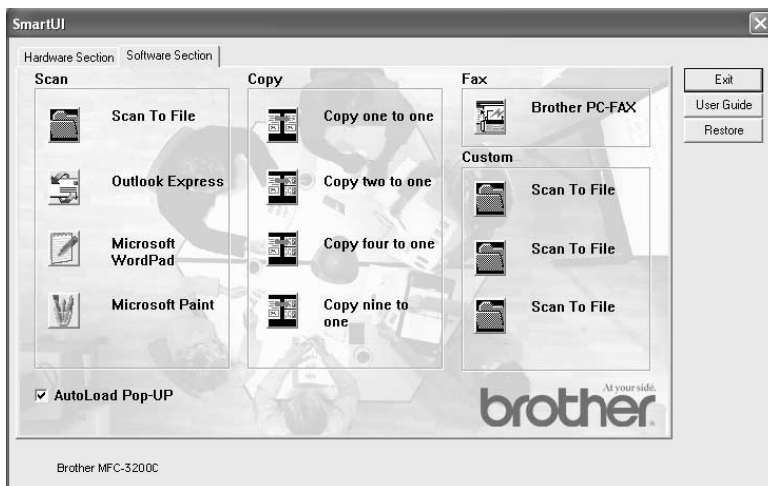

- 3 Uncheck the AutoLoad Pop-Up option to prevent the SmartUI from automatically loading every time Windows is started.

# Brother Control Center Features

---

The SmartUI control center gives you the ability to both configure the hardware “Scan to” keys on your MFC and to use additional built in software features such as “Scan to File”. The “Scan to File” feature allows you to scan a document directly to your hard disk in the directory and file format of your choice without having to run any other applications. Select which section you want by clicking on the appropriate tab.

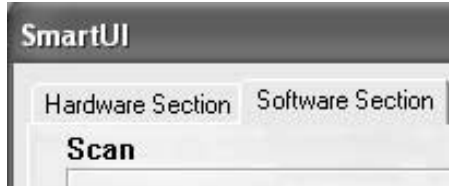

## Auto Configuration

During the installation process the Control Center checks your system to determine the default applications for E-mail, word processing and graphics viewer/editor.

**For example**, if you are using Outlook as your default E-mail application, the Control Center automatically will create a link and a scanning application button for Outlook.

You can change the default application by right clicking on any of the scan buttons in the Control Center and then clicking Configuration. Select the Configuration tab and from the Application pull down menu select a different application. For example, you can change the E-mail scan button from Outlook Express to Outlook by changing the application that is listed.

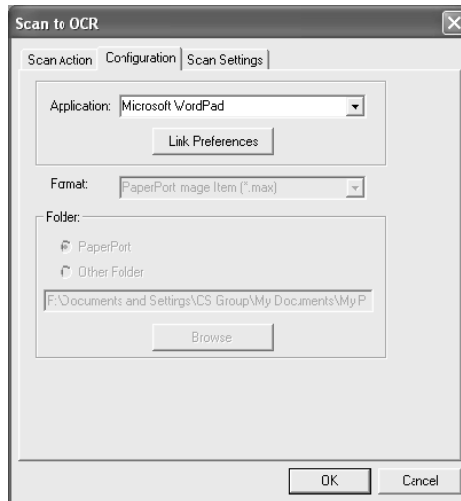

# Hardware Section: Changing the Scan to Button Configuration

When the SmartUI Control Center is displayed, you can access the Hardware Section window to reconfigure the Scan to buttons on you Brother MFC. Click the Hardware Section tab at the top left of the SmartUI Control Center screen. (For details about how to use the scan to key, see *Using the Color Scan Key*, page 17-9.)

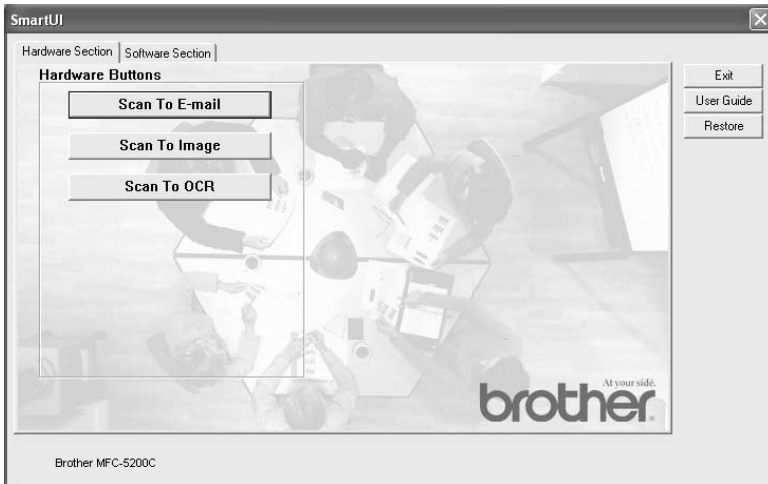

## Scan To E-mail

To configure the Scan to E-mail feature left click on the Scan to E-mail button and the following screen will appear. You have the ability to change the configuration that includes the destination E-mail application, attachment file and the scanner settings.

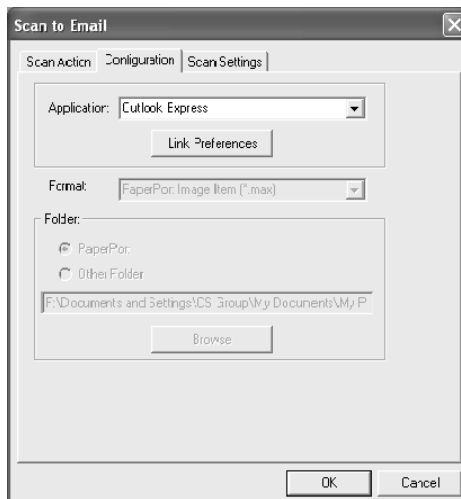

To change the destination E-mail application you use the Application pull down list to select the compatible E-mail application, which is installed on your system.

If you wish to change the attachment file type click on the Link Preferences button to display a list of file types.

## Scan To Image

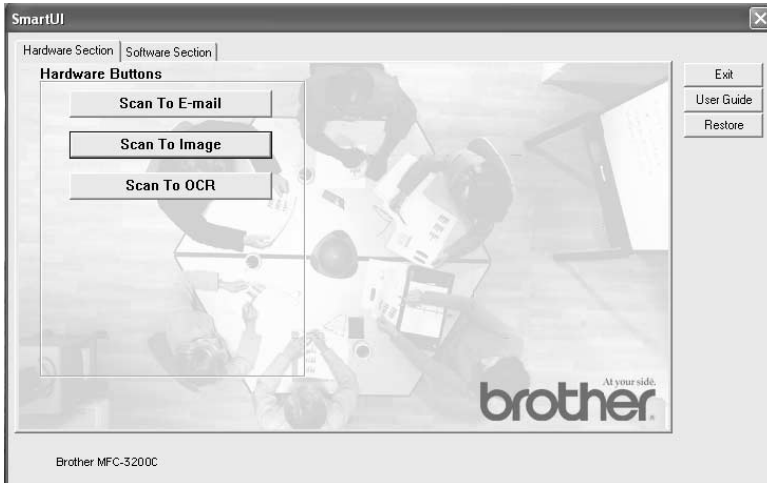

To configure the Scan to Image feature left click on the Scan to Image button and the following screen will appear. You have the ability to change the configuration, which includes the destination image format or document application.

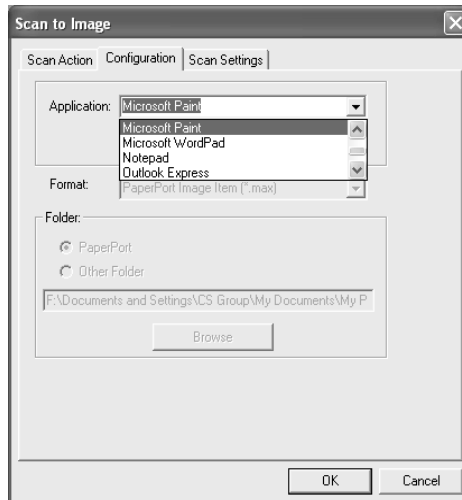



To change the default setting of the scan, click on the Scan Settings tab.

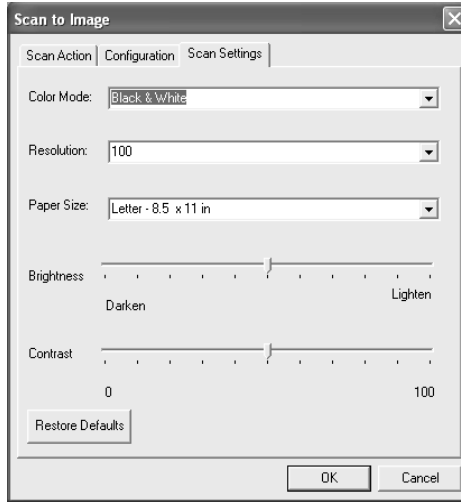

You can set the Color Mode to Black & White, 8-bit Gray or 24-bit Color.



Color Scanning may not be supported by your specific model MFC. Please check the specifications for your particular model MFC.

The resolution can be changed from 100 to 600 dpi. You can define the size of the paper you're using, and you can adjust the brightness and contrast of the image before scanning.

## Scan To OCR

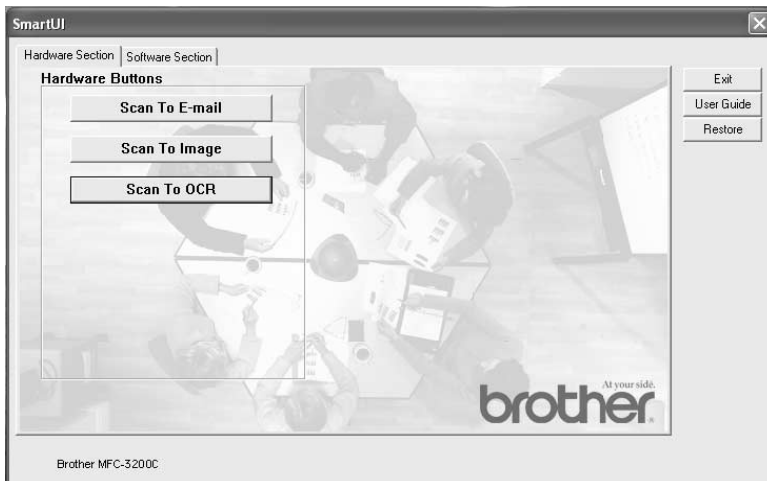

To configure the Scan to OCR feature left click on the Scan to OCR button and the following screen will appear. You have the ability to change the configuration, which includes the destination application.

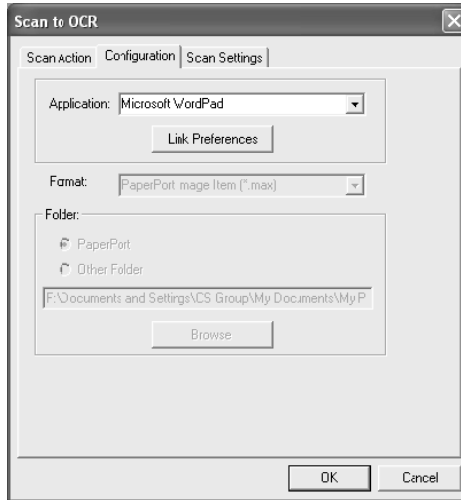

You have the option to send your scan as a different file type. You can select the application from the File Type window according to your needs.

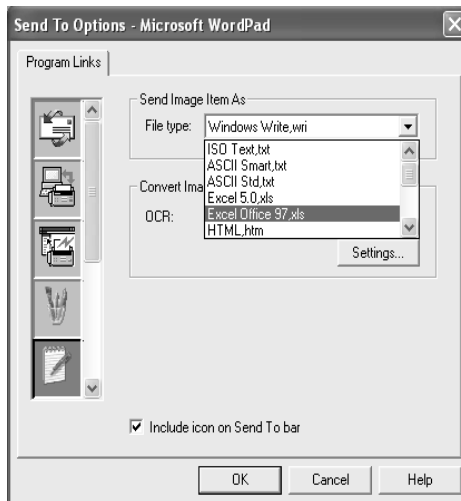

You have the option to choose your OCR setting from single column output to auto orient page.

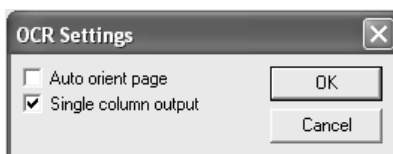

# Software Section

The Software Section contains four groups of scan to buttons. Each section has a number of different buttons which are predefined for the most frequently used applications. The Scan Section contains four buttons for Scan to File, Scan to E-mail, Scan to Word Processor and Scan to Image applications. The Copy Section contains four buttons for N to 1 copying. The Fax Section button is for sending faxes using the Brother PC-FAX application and the Custom section contains three buttons with which you can assign your own function.

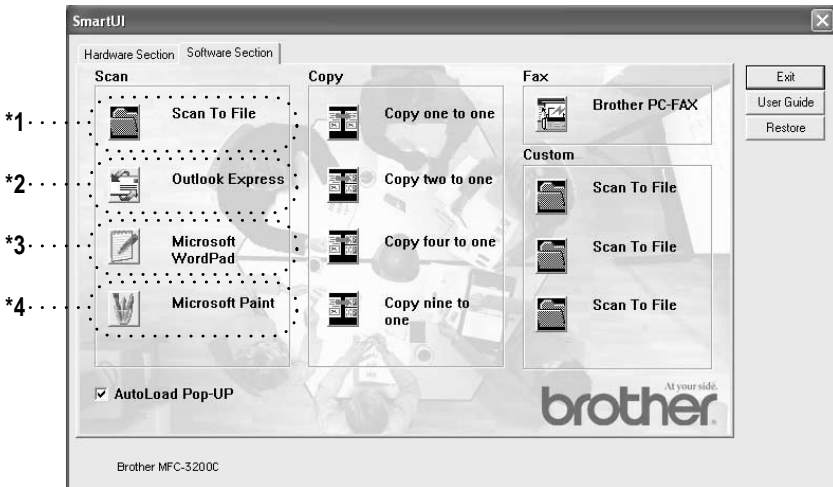

## Scan

\*1 *Scan to File* —enables you to scan directly to a disk file. You can change the file type and destination directory, as needed.

\*2 *Scan to E-mail (Default: Outlook Express)* —enables you to scan a page or document directly into an E-mail application as a standard attachment. You have the option of selecting the file type and resolution for the attachment.

\*3 *Scan to Word Processor (Default: MS WordPad)* —enables you to scan a page or document, automatically run ScanSoft TextBridge OCR and insert the text (not graphic image) into a word processing program. You have the option of selecting the destination word processing program, such as WordPad, MS Word, Word Perfect or whichever word processing program is installed on your computer.

\*4 *Scan to Graphic Application (Default: MS Paint)* —enables you to scan a page directly into any graphic viewer/editor application. You can select the destination application, such as MS Paint, Corel PhotoPaint, Adobe PhotoShop, or any kind of image editor application you already have installed on your computer.

## Copy

*Copy (Copy one to one)*—allows you to use the PC and any Windows® printer driver for enhanced copy operations. You can scan the page on the Brother MFC and print the copies using any of the features of the Brother MFC printer driver—**OR**—you can direct the copy output to any standard Windows® printer driver installed on the PC including network printers.

*Nine/Four/Two to One Copy*—enables you to use the Nine/Four/Two on One-page features of the Brother printer driver to copy nine/four/two original pages onto a single output page. (NOTE: This feature may not be supported by your specific model MFC. Please check the specifications for your specific model MFC. The number of Copy buttons may vary depending on which model MFC you have purchased.)

## Fax

*Send a Fax (Brother PC-FAX)*—enables you to scan a page or document and automatically send the image as a fax from the PC using the Brother PC-FAX software.

## Custom

*Scan to File*—These buttons have been pre-programmed for the Scan to File feature. You can change the configuration of each of these buttons to meet your specific requirements by right clicking on a button and following the configuration menus. (NOTE: The number of Custom buttons may vary depending on which model MFC you have purchased.)

## Scan to File

The Scan to File button allows you to scan an image and save it in a specific file type to any directory on your hard disk. This allows you to easily archive your paper documents. To configure the file type and save to directory, right-click on the Scan to File button and click Configuration.

The Scan Action tab is set to File and should not be changed.



To change the configuration, click on the Configuration tab.

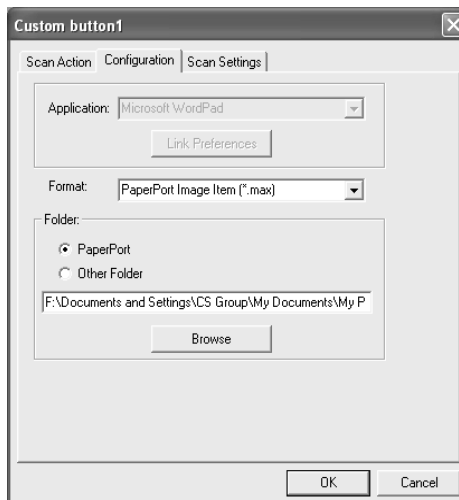

Select the file type for the saved image by selecting from the Format pull-down list. You can save the file to the default PaperPort folder so the file appears in PaperPort or you can select another folder/directory by clicking the Browse button. You can default setting by selecting the Other Folder button and then clicking Browse and selecting the folder in which you wish to save your files.

# Scan to E-mail

---

The Scan To E-mail is automatically configured to your default E-mail application. To change the default E-mail application or attachment file type right click on the E-mail button and select “Configuration”.

The Scan Action tab is set to E-mail and should not be changed.

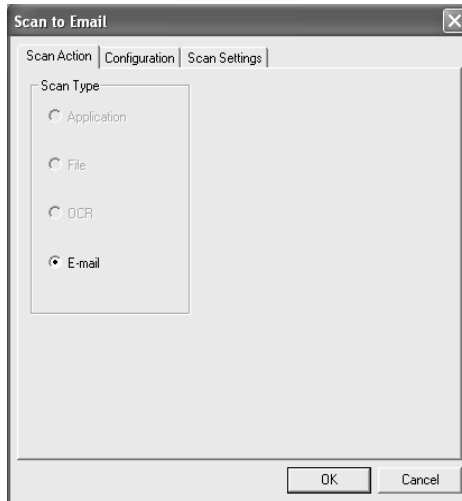

To change the E-mail application click on the Configuration tab. From Application pull down list select your preferred E-mail application.

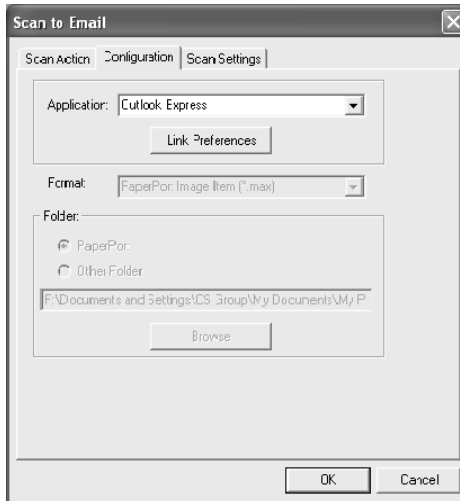

To change the file type of the attachment click the **Link Preferences** button to set up links. Check the **Convert attachment to specified file type** box and then select the appropriate file type from the pull down list.

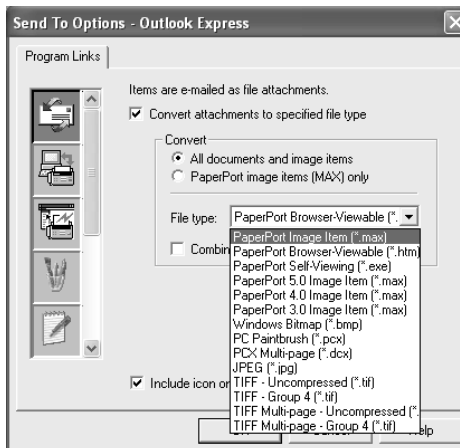

## File Attachments

Items are mailed as file attachments using the file type you have selected.

*Convert attachments to specified file type*—Click this checkbox if you want to change the file type of attachments.

*All documents and image items*—Click this checkbox if you want to convert all scanned images to the same file type.

*PaperPort image items (MAX) only*—Click this checkbox if you want to convert only attachments that are PaperPort MAX files.

*Combine items into single file, if possible*—Click this checkbox if you want to combine all the attachments into one file. With this box unchecked each scanned page will be saved in its own individual file.

*File Type*—Select from the pull-down list the type of file you want the scanned images to be saved in.

- PaperPort Image Item (\*.MAX)
- PaperPort Self Viewing (\*.EXE)
- PaperPort Browser-Viewable (\*.HTM)
- PaperPort 5.0 Image Item (\*.MAX)
- PaperPort 4.0 Image Item (\*.MAX)
- PaperPort 3.0 Image Item (\*.MAX)
- Windows Bitmap (\*.BMP)
- PC Paintbrush (\*.PCX)
- PCX Multi-page (\*.DCX)
- JPEG (\*.JPG)
- TIFF-Uncompressed (\*.TIF)
- TIFF Group 4 (\*.TIF)
- TIFF Class F (\*.TIF)
- Multi-Page -Uncompressed (\*.TIF)
- Multi-Page - Group 4 (\*.TIF)



## Scanner Settings

You have the ability to change the scanner settings used to create the file attachments. Click on the Scan Settings tab and select the appropriate settings.

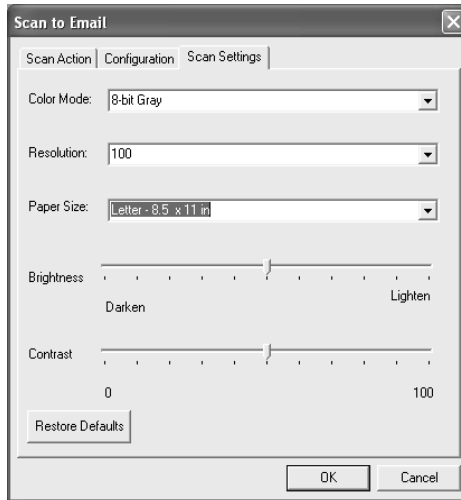

# Scan to OCR (Word Processing Program)

Scan to OCR converts the graphic page image data to text which can be edited by any word processor program. You can change the default word processor program (example: Word Pad instead of Word) and file type. You can also choose other OCR software package besides the TextBridge OCR which is built in PaperPort.

To configure Scan to OCR right click on the WordPad button and select Configuration. The Scan Action tab is set to OCR and should not be changed.

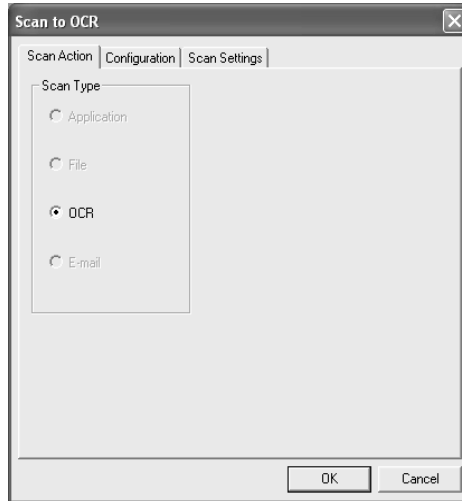

To change the word processing application click on the Configuration Tab. You can select the destination word processing application from the Application pull down list.

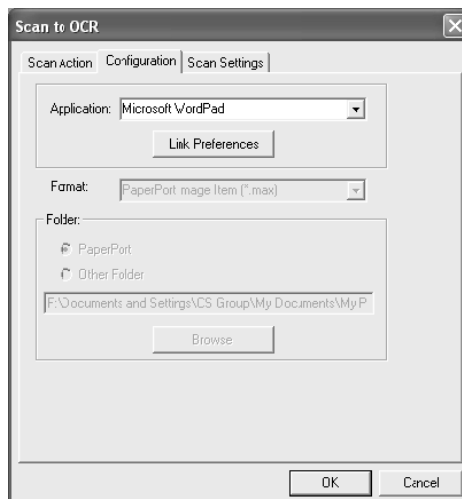

To change the program link preferences click the Link Preferences button.

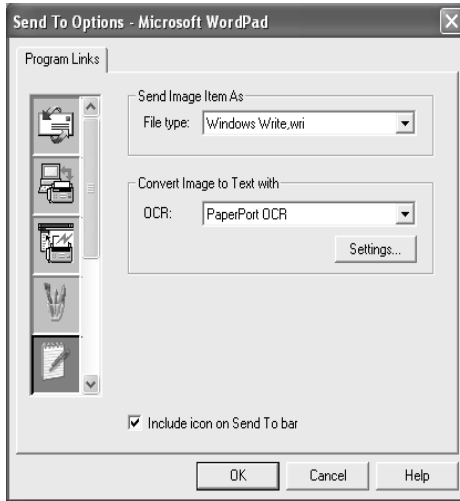

*File Type*—From the pull-down list, select the file format you want to use for documents.

*OCR*—Select the OCR application from the OCR pull down list.

# Scan to Graphics Application (example: Microsoft Paint)

---

The Scan to Graphics Applications allows you to scan an image so you can edit the image. To change the default graphics application right click on the button and select Configuration.

The Scan Action tab is set to Application and should not be changed.

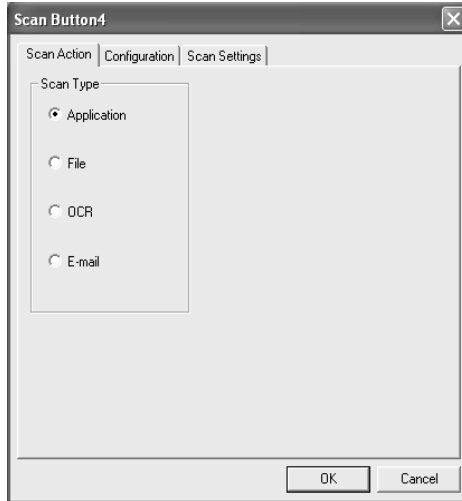

To change the configuration of the destination application click on the Configuration Tab.

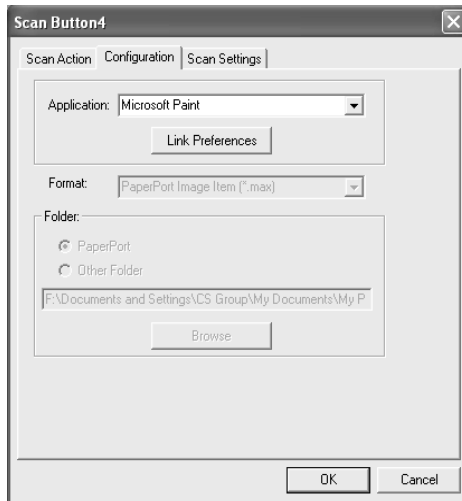

To change the destination application select the appropriate application from the Application pull down list.

To change the other configuration options click the Link Preferences button.

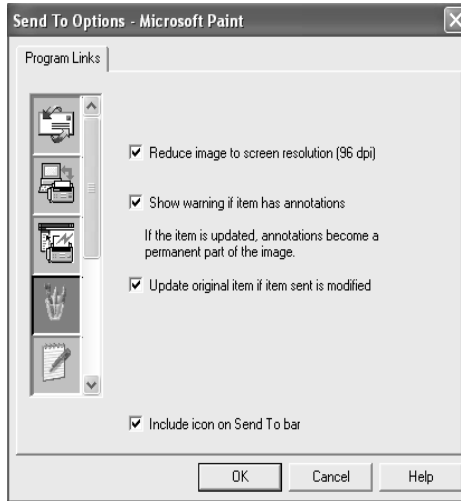

This option enables you to reduce image to screen resolution (96dpi), show warning if item has annotations, update original item if sent item is modified, if needed.

## Copy

The four copy buttons can be customized to allow you to take advantage of the features built into the Brother printer drivers to do advanced copy functions such as n-in-1 printing.

The Copy buttons are automatically linked to the default Windows printer driver. You can set any printer as the default printer including non-Brother printers. Before you can use the Copy buttons you must first configure the printer driver by right clicking on a Copy button and selecting Configuration.

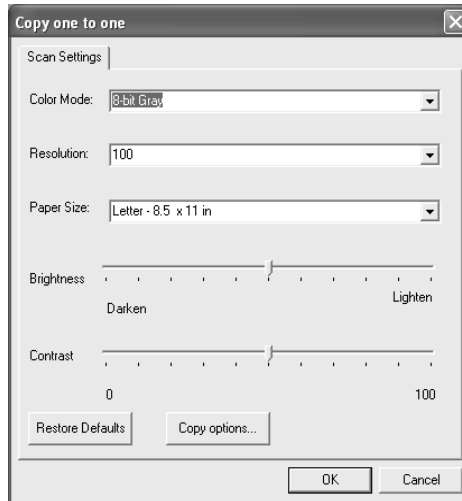

In the Scan Settings window you can select the color mode, resolution, paper size, brightness and contrast settings to be used. (NOTE: Selecting 24-bit Color will give you color output only when the destination printer is a color printer.)

To finish the Copy button configuration you must set the printer driver. Click the Copy options button to display the printer driver settings.



The copy options screen will vary depending upon which Brother MFC model you have purchased.

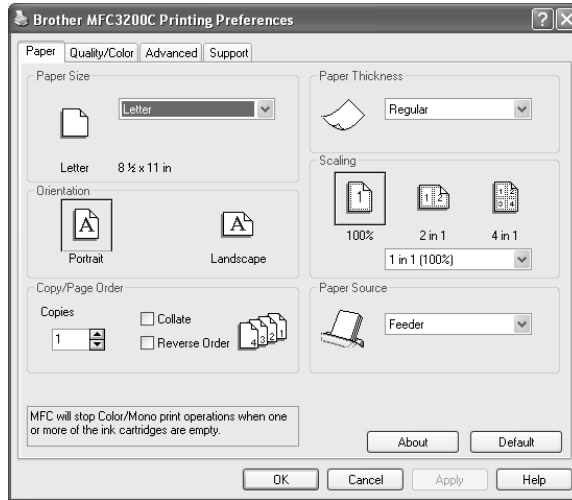

Select the number of Pages Per Sheet from the Scaling selections. As an example to configure the section Copy button to copy two pages to one you must select 2 in 1.



You must configure each of the copy buttons before they can be used.

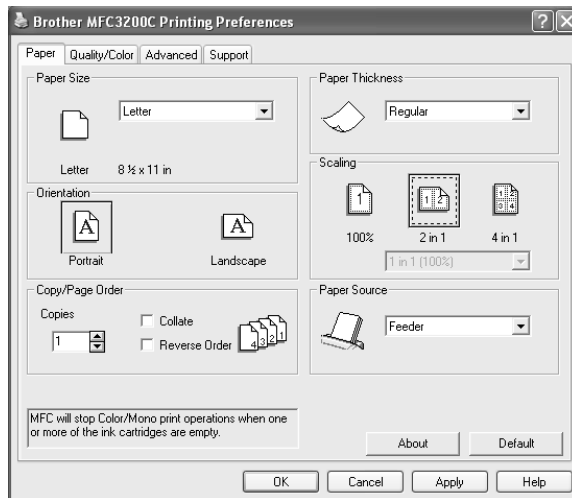

# Fax Setting (PC Fax using the Brother Fax Driver)

---

The Brother MFC includes a PC-Fax driver, which allows any Windows Application to send a Fax as simply as printing a document. The Brother SmarUI automatically configures the Fax button to use the Brother PC-FAX driver no user configuration is required.

The Scan Action tab is set to Application and should not be changed.



To change the PC-FAX settings click the Link Preferences button.

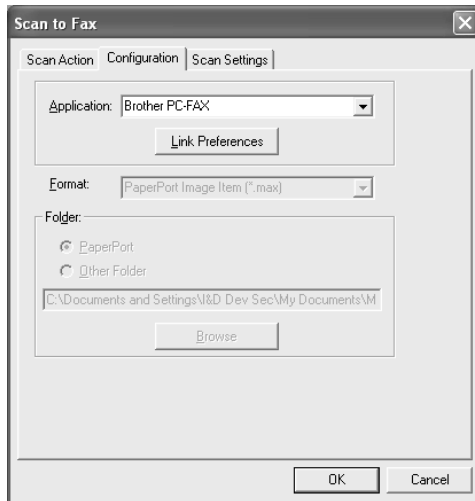



# FAX Settings

## Brother PC-FAX



To change the driver settings, click on the Setup button and then the Options button.

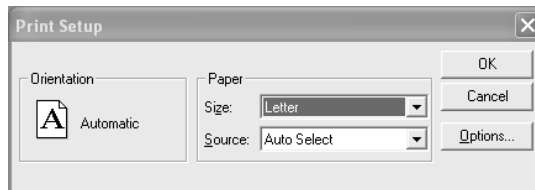

Select the *Paper Size*, *Paper Source*. If you need more customized setup, click on the Options button.

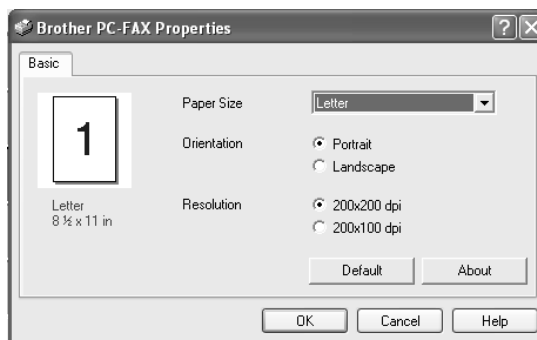

Select the *Paper Size*, *Orientation* (Portrait or Landscape) and *Resolution* (200x200 dpi or 200x100 dpi), and click **OK**.

To return to the factory default settings, click the **Defaults** button.

# Custom: User Defined Buttons

---

There are up to three Custom buttons on the Brother SmartUI Control Center. (NOTE: The number of Custom buttons depends on which model MFC you have purchased.) You can set your own preferences and configuration to fit your required application.

To configure a Custom Button right click on the button and then click Configuration. The configuration window will appear. You have four function choices Application, File, OCR and Email.

**Application:** This setting will link the Control Panel button to any button which appears on the PaperPort Send to Bar. Please see the PaperPort help file for more information regarding PaperPort compatible applications.

**File:** This setting allows you to save a scanned image to any directory on local or network hard disk. You can also select the file format to be used.

**OCR:** Scanned documents will be converted to editable text files. If you have a third party OCR software package installed on your PC you can select it. The default OCR software is TextBridge which is built into PaperPort 8.0. You can also select the destination word processor and file format for the editable text.

**E-mail:** Scanned images will be attached to an email message. You can choose which E-mail package to use if you have more than one installed on your system. You can also select the file type for the attachment and create a quick send list of E-mail addresses chosen from your default E-mail address book.

## Customizing a User Defined Button

To configure a Custom button right click on the button and then click Configuration. Please follow the following guide lines for Custom Button configuration.

### 1. Select the Scan Action

Select the type of scan by clicking the appropriate button.

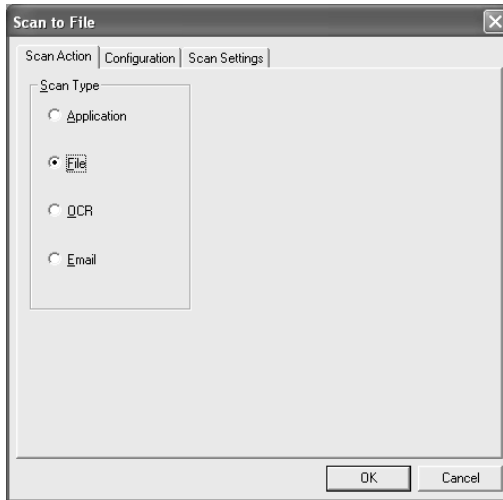

## 2. Select Configuration for the Scan Type.

To configure the scan operation click on the Configuration Tab. Depending upon which Scan Type button you selected you will see a different Configuration Tab list of settings.

### ***Application:***

Select the destination application program from the pull down list.

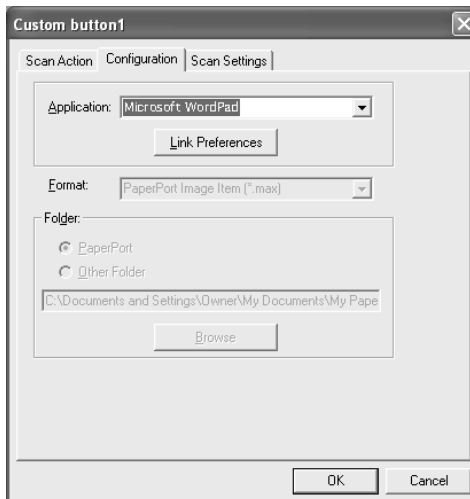

Click on Link Preferences to set the Send to options. You can select the application from the scroll menu on the left.



***File:***

Select the file format from the Format pull down list. You can either send the file to the default PaperPort directory or select your own destination directory by selecting Other Folder. Use the Browse button to select the destination directory.

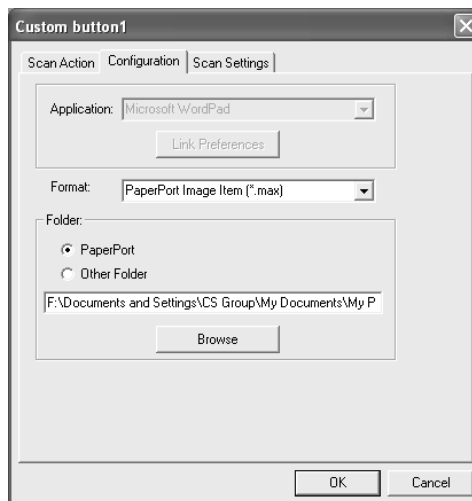

## OCR:

Select the destination word processing application program from the pull down list.

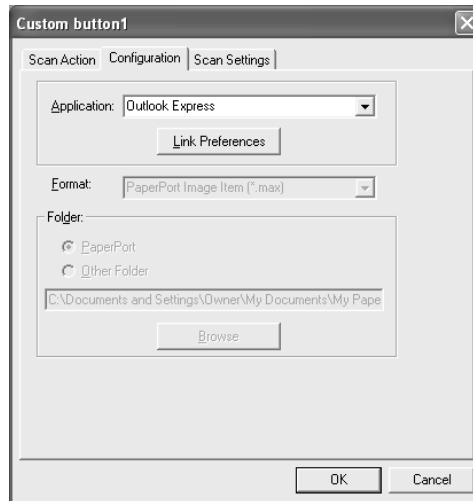

Click on Link Preferences and select the destination Application from the scroll menu on the left. Select the File Type from the File Type pull down list. You can also choose another OCR application from the OCR pull down list if another is installed on you system. Scansoft TextBridge is installed as port of the PaperPort 8.0 application.

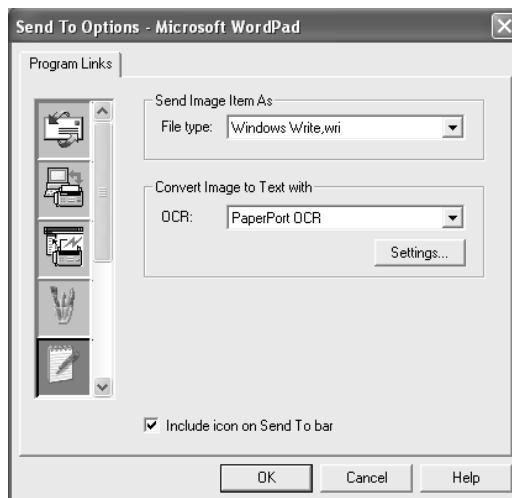

## ***E-mail:***

Select the destination E-mail application program from the pull down list.

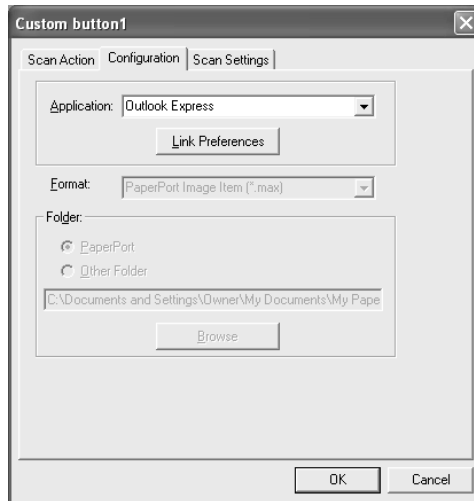

Click on the Link Preferences button to configure the Send To E-mail options. You can select the File type and Quick Send E-mail address list.

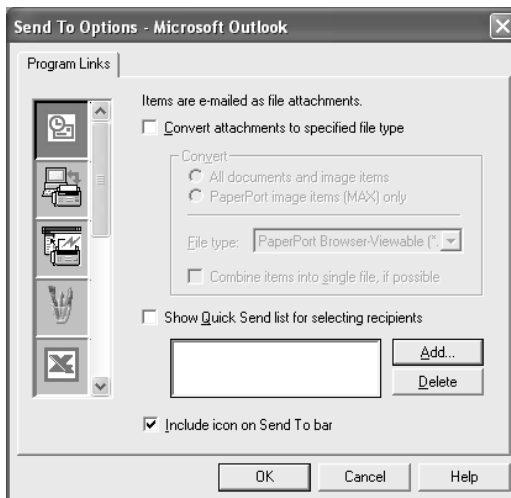

### 3. Select Scan Settings.

You can select the scanner settings from each of the Scan Type options for the Custom Buttons. You have the option to select Color Mode, (NOTE: Color scanning may not be available based on which MFC you purchased. Please check the specifications of your MFC.) Resolution, Paper Size and Brightness and Contrast settings.

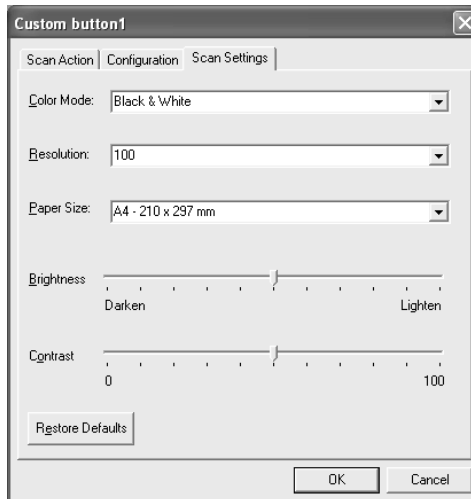

# 17 How to scan using Windows®

## Scanning a Document (For Windows® 98/98SE/Me and 2000 Professional)

### TWAIN Compliant

The Brother Multi-Function Link® Pro software includes a TWAIN compliant scanner driver. TWAIN drivers meet the standard universal protocol for communicating between scanners and software applications. This means that not only can you scan images directly into the PaperPort® viewer that Brother included with your MFC, but you can also scan images directly into hundreds of other software applications that support TWAIN scanning. These applications include popular programs like Adobe Photoshop®, Adobe PageMaker®, CorelDraw and many more.

### How to Access the Scanner

- 1 Open the software application (ScanSoft™ PaperPort®) to scan a document.
-  The instructions for scanning in this guide are for when you use ScanSoft™ PaperPort®.
- 2 Choose **Select source** from the File drop-down menu and then select **TWAIN\_32 Brother MFLPro Color**.
- 3 Select **Acquire** from the File drop-down menu.

The **TWAIN\_32 Brother MFL-Pro Color Setup** dialog box will appear:

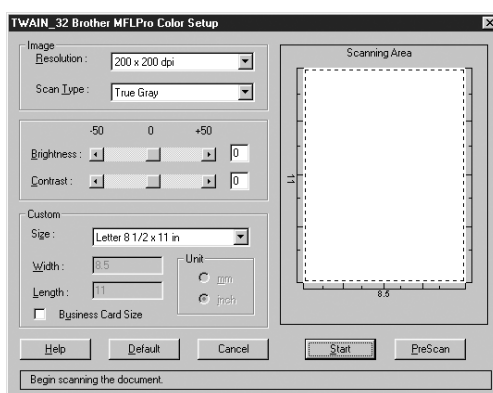

### Scanning a Document into the PC

You can scan a whole page

—OR—

scan a portion of the page after pre-scanning the document.



## Scanning a whole page

- 1 Place the original face down in the ADF (Automatic Document Feeder).
- 2 Adjust the following settings, if required, in the Scanner window:
  - *Resolution*
  - *Scan Type* (Black & White, Gray [Error Diffusion], True Gray, 256 Color or 24-bit color)
  - *Brightness*
  - *Contrast*
  - *Size*
- 3 Click the **Start** button in the scanner window.  
When scanning is completed, click **Cancel** to return to the PaperPort® window.

## PreScanning to crop a portion you want to scan

The **Pre-Scan** button is used to preview an image for cropping any unwanted areas from the image. When you are satisfied with the preview, click the **Start** button in the scanner window to scan the image.

### How to Use PreScan to Adjust an Image:

- 1 Place the original face down in the ADF.
- 2 In the Twain-32 Brother MFLPro Color Setup dialog box, click the **PreScan** button.  
The entire original will be scanned into the PC and will appear in the Scanning Area.

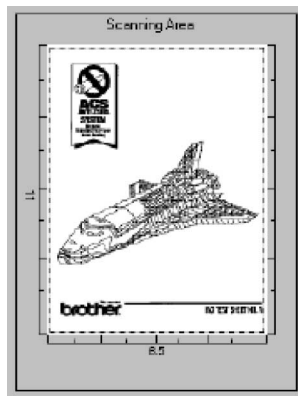

**PreScanned Image**

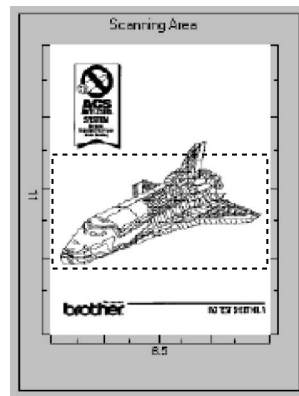

**Cropped Image**

- 3 To crop a portion of the original to be scanned, drag any side or corner of the dotted outline in the Scanning Area with the left mouse button. Adjust the dotted outline until it surrounds only the portion of the original you wish to scan.

- 4 Place the original face down in the ADF again.
- 5 Adjust the settings for Resolution, Scan Type and Size in the Scanner window, as needed.
- 6 Select the **Start** button.  
This time only the selected area of the original will appear in the PaperPort® window.
- 7 In the PaperPort® window, use the options available to refine the image. (See PaperPort® for Brother Online Documentation on the CD-ROM for details.)

## Settings in the Scanner Window

### Resolution:

Resolution: Select the scanning resolution from the Resolution drop down list. Higher resolutions take more memory and transfer time, but can achieve a finer scanned image. You can choose:

Resolution	Black & White / Gray (Error Diffusion)	256 color	True Gray / 24 bit color
100 × 100 dpi	Yes	Yes	Yes
150 × 150 dpi	Yes	Yes	Yes
200 × 100 dpi	Yes	No	No
200 × 200 dpi	Yes	Yes	Yes
200 × 400 dpi	Yes	No	No
300 × 300 dpi	Yes	Yes	Yes
400 × 400 dpi	Yes	Yes	Yes
600 × 600 dpi	Yes	Yes	Yes
1200 × 1200 dpi	Yes	No	Yes
2400 × 2400 dpi	Yes	No	Yes

### Scan Type:

Black & White: Set the Scan Type to Black & White for text or line art.

Gray Scale: For photographic images, set the Scan Type to Gray (Error Diffusion) or True Gray.

Colors: Choose either 256 Color, which scans up to 256 colors, 24-bit color which scans up to 16.8 million colors. Although using 24-bit color creates an image with the most accurate colors, the image file will be approximately three times larger than a file created with 256 Color.

## **Brightness:**

Brightness: Adjusting the brightness settings to obtain the best image. The Brother Multi-Function Link® Pro offers 100 brightness settings (-50 to 50). The default value is 0, representing an “average” setting.

You can set the brightness level by dragging the sidebar to the right to lighten the image or to the left to darken the image. You can also type a value in the box to set the settings.

If the scanned image is too light, set a lower brightness value and scan the document again.

If the image is too dark, set a higher brightness value and scan the document again.

## **Contrast:**

The contrast setting is adjustable only when you have selected one of the gray scale settings, but it is not available when Black & White is selected as the Scan Type.

Increasing the contrast level (by dragging the sidebar to the right) emphasizes dark and light areas of the Image, while decreasing the contrast level (by dragging the sidebar to the left) reveals more detail in gray areas. Instead of using the sidebar, you can type a value in the box to set the contrast.

## **Size:**

Set the Size to one of the following:

- Letter (8 1/2 × 11 in.)
- A4 (210 × 297 mm)
- Legal (8 1/2 × 14 in.)
- A5 (148 × 210 mm)
- B5 (182 × 257 mm)
- Executive (7 1/4 × 10 1/2 in.)
- Business Card (90 × 60 mm)
- Custom (User adjustable from 0.35 × 0.35 in. to 8.5 × 14 in.)

After you select a custom size, you can adjust the scanning area further by using the left mouse button to drag the dotted outline of the scanning area. This is required when you want to crop an image when scanning.

To scan business cards, select the Business Card (90 × 60 mm) size setting and place the business card at the top center of a carrier sheet.



Carrier sheets are available from your Dealer.

When scanning photographs or other images for use in a word processor or other graphics application, you should try different settings for the contrast, mode and resolution to see which settings best suit your needs.

**Custom:**

If you selected **Custom** as the size, type the **Width** and **Length**.

Or, you can check the Business Card Size box to adjust the scanning area to business card or a custom size automatically.

# Scanning a Document (For Windows® XP only)

## WIA compliant

Windows® XP uses Windows Image Acquisition (WIA) for scanning images from the MFC. You can scan images directly into the PaperPort® viewer that Brother included with your MFC or you can scan images directly into any other software application that supports WIA or TWAIN scanning.

## How to Access the Scanner

- 1 Open your software application to scan a document.
- 1  The instructions for scanning in this guide are for when you use ScanSoft™ PaperPort® ver.8.0. The steps for scanning from another application may vary.
- 2 Select **Scan** from the **File** drop-down menu or select the Scan button. The **Scan** pane appears in the left panel.
- 3 Select the scanner you are using from the **Scanner** drop-down list box.

The Scan dialog box will appear:

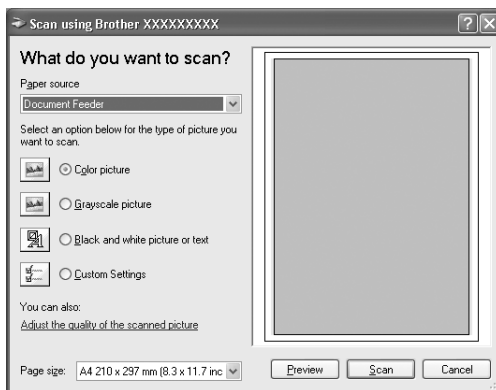

# Scanning a document into the PC

- 1 Place the original face down in the ADF (Automatic Document Feeder).

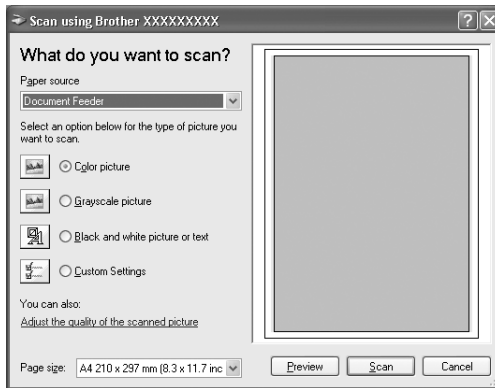

- 2 Select the **Document Feeder** from the **Paper source** drop-down list box (A).
- 3 Select the picture type (B).
- 4 Select the **Paper size** from the drop-down list box (D).
- 5 If you require advanced settings, click **Adjust the quality of the scanned picture** (C). You can select **Brightness**, **Contrast**, **Resolution** and **Picture Type** from the **Advanced Properties**. Click the **OK** button after you choose your settings.



The scanner resolution you can select is up to 600 × 600 dpi.

- 6 To start scanning your document, click the **Scan** button in the Scan dialog box.

## Brother Scanner Utility

The Brother Scanner Utility is used for configuring the scanner driver for resolutions greater than 600dpi.

To run the utility:

You can run the utility by selecting the Scanner Utility located in the **Start/Program/Brother/Brother MFL Pro Suite** menu.



Scanning at resolutions greater than 600dpi may cause problems with some scanning applications.

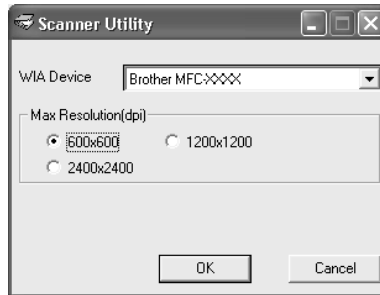

# Using the Color Scan Key

You can use the **Scan to** key on the control panel to scan originals into your word processing, graphics or E-mail applications. The advantage of using the **Scan to** key is that you avoid the mouse clicks required to scan from your PC.



- ⊘ If you have connected a Macintosh, the control panel keys will not work with your computer. Please see page 21-1.

Before you can use the **Scan to** key on the control panel, you must have connected the MFC to your Windows® based PC and loaded the appropriate Brother Drivers for your version of Windows®. When you are ready to use the **Scan to** key, make sure the Brother Control Center application is running on your PC. (For details about how to configure the Brother Control Center buttons to launch the application of your choice using the **Scan to** key, see *Brother Control Center Features*, page 15-6 to 15-11 or 16-4 to 16-7.)

## Scan to E-mail

You can scan either a black and white or a color original into your E-mail application as a file attachment. Although the Brother Control Center can be configured to send only black and white or color file attachments at one time, you can easily change this setting. (For details see *Scan to E-mail*, pages 15-7 to 15-9.)

- 1 Place the original face down in the ADF.
- 2 Press **Scan to**.
- 3 Press  to select **SCAN TO E-MAIL**, and then press **Menu/Set**.

The MFC will scan the original, create a file attachment, and launch your E-mail application, displaying the new message waiting to be addressed.

## Scan Image

You can scan a color picture into your graphics application for viewing and editing.

- 1 Place your original face down in the ADF.
- 2 Press **Scan to**.
- 3 Press  to select **SCAN IMAGE**, and then press **Menu/Set**.



## Scan/OCR

If your original is text, you can have it automatically converted by ScanSoft™ TextBridge® to an editable text file and then displayed in your word processing application for further editing.

- 1 Place your original face down in the ADF.
- 2 Press **Scan to**.
- 3 Press  to select **SCAN/OCR**, and then press **Menu/Set**.

The MFC will scan the original perform OCR in ScanSoft™ TextBridge®, and then display the result in your word processing application for viewing and editing.

# Using ScanSoft™ PaperPort® 6.5 and TextBridge® OCR (For Windows® 98/98SE/Me and 2000 Professional)

ScanSoft™ PaperPort® for Brother is a document management application. You will use PaperPort® to view scanned documents. PaperPort® has a sophisticated, yet easy-to-use, filing system that will help you organize your graphics and text documents. It allows you to combine or “stack” documents of different formats for printing, faxing or filing. ScanSoft™ PaperPort® can be accessed through the ScanSoft™ PaperPort® program group. See *On-Line Documentation for Multi-Function Link® Pro* on the CD-ROM.

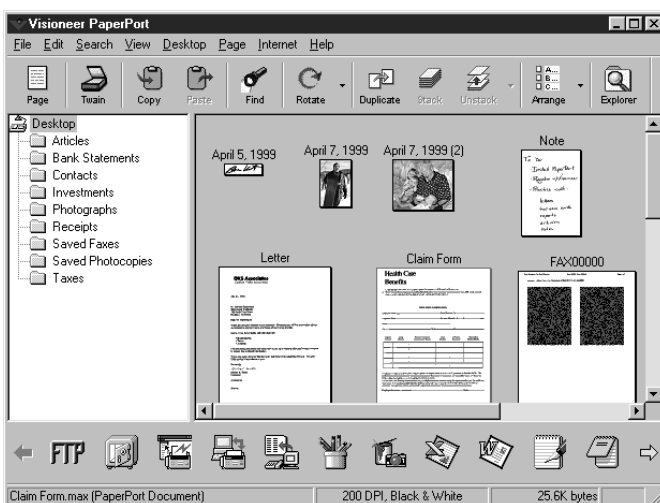

The complete ScanSoft™ PaperPort® User’s Guide, including ScanSoft™ TextBridge® OCR, is in the On-Line Documentation on the CD-ROM. This chapter is only an introduction to the basic operations.

When you install Multi-Function Link® Pro, ScanSoft™ PaperPort® for Brother and ScanSoft™ TextBridge® OCR are installed with it automatically.



## To Uninstall PaperPort® and ScanSoft™ TextBridge

*For Windows® 98/98SE, and Windows® ME and Windows® 2000 Professional:*

Select Start, Settings, Control Panel, Add/Remove Programs and the Install/Uninstall tab. Select PaperPort® from the list and click the Add/Remove button.

# Viewing Items in ScanSoft™ PaperPort® for Brother

ScanSoft™ PaperPort® provides several ways to view items:

**Desktop View** displays a **thumbnail**, a small graphic that represents each item in a Desktop or folder. Items in the selected folder appear on the PaperPort® Desktop. You can see PaperPort® items (MAX files) and non-PaperPort® items (files created using other applications). Non-PaperPort® items include an icon that indicates the application that was used to create the item; a non-PaperPort® item is represented by a small rectangular thumbnail and not an actual image.

**Page View** displays a close-up of a single page and you can open a PaperPort® item by double-clicking on it. As long as you have the appropriate application on your computer to display it, you can also double-click a non-PaperPort® item to open it.

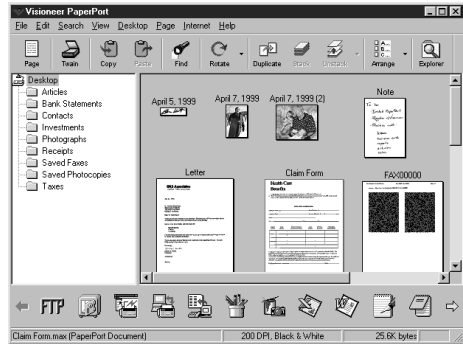

Desktop View displays items as thumbnails

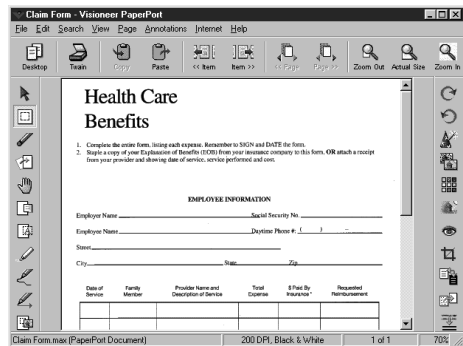

Page View displays each item as a full page

## Organizing Your Items in Folders

PaperPort® has an easy-to-use filing system for organizing your items. The filing system consists of folders and items that you select to view in Desktop View. An item can be a PaperPort® item or a non-PaperPort® item:

- Folders are arranged in a “tree” structure in the Folder View. You use this pane to select folders and view their items in Desktop View.
- You can simply drag and drop an item onto a folder. When the folder is highlighted, release the mouse button and the item is stored in that folder.
- Folders can be “nested”—that is, stored in other folders.
- When you double-click a folder, its items (both PaperPort® MAX files and other files) appear on the Desktop.
- You can also use Windows® Explorer to manage the folders and items shown in Desktop View.

## Links to Many Other Applications

ScanSoft™ PaperPort® automatically recognizes many other applications on your computer and creates a “working link” to them. The Link Bar at the bottom of Desktop view shows icons of those linked applications. To use a link, drag an item onto one of the icons to start the application represented by the icon. A typical use of the Link Bar is to select an item and then fax it.

This sample Link Bar shows several applications with links to PaperPort®.



If PaperPort® does not automatically recognize one of the applications on your computer, you can manually create a link using the **Create New Link** command. (See *PaperPort®* in the On-Line-Documentation on the CD-ROM for more information about creating new links.)

## Using ScanSoft™ TextBridge® OCR (Converting Image Text to Text You Can Edit)

Software by: 

ScanSoft™ TextBridge® OCR is installed automatically with PaperPort® when you install Multi-Function Link® Pro on your computer.

ScanSoft™ PaperPort® can quickly convert the text on a ScanSoft™ PaperPort® item (which is really just a picture of the text) into text that you can edit with a word processing application. PaperPort® uses the optical character recognition application ScanSoft™ TextBridge®, which comes with PaperPort®—**OR**—PaperPort® uses your application if it is already on your computer. You can convert the entire item, or by using the **Copy As Text** command, you can select only a portion of the text to convert.

Dragging an item onto a word-processing link icon starts PaperPort®’s built-in OCR application, or you can use your own OCR application.



## Importing Items from Other Applications

In addition to scanning items, you can bring items into PaperPort® in a variety of ways and convert them to PaperPort® (MAX) files in several different ways:

- Print to the Desktop View from another application, such as Microsoft Excel.
- Import files saved in other file formats, such as Windows® Bitmap (BMP) or Tag Image File Format (TIFF).

## Exporting Items in Other Formats

You can export or save PaperPort® items in several popular file formats, such as BMP, JPEG, TIFF, or self-viewing. For example, to create a file for an Internet Web site, export it as a JPEG file. Web pages often use JPEG files for displaying images.

### Exporting an Image File

- 1 Select the Export command from the File pull-down menu in the PaperPort® window. The Export 'XXXXX' As dialog box will be displayed.
- 2 Select the drive and directory where you want to store the file.
- 3 Enter the new file name and choose the file type or select a name from the File Name text box. (You can scroll through the Directories and File Name listing for prompting.)
- 4 Select the **OK** button to save your file, or **Cancel** to return to the PaperPort® without saving it.

# Using ScanSoft™ PaperPort® 8.0 and TextBridge® OCR (For Windows® XP)

ScanSoft™ PaperPort® for Brother is a document management application. You will use PaperPort® to view scanned documents.

PaperPort® has a sophisticated, yet easy-to-use, filing system that will help you organize your graphics and text documents. It allows you to combine or “stack” documents of different formats for printing, faxing or filing.

ScanSoft™ PaperPort® can be accessed through the ScanSoft™ PaperPort® program group.

See On-Line Documentation for Multi-Function Link® Pro on the CD-ROM.

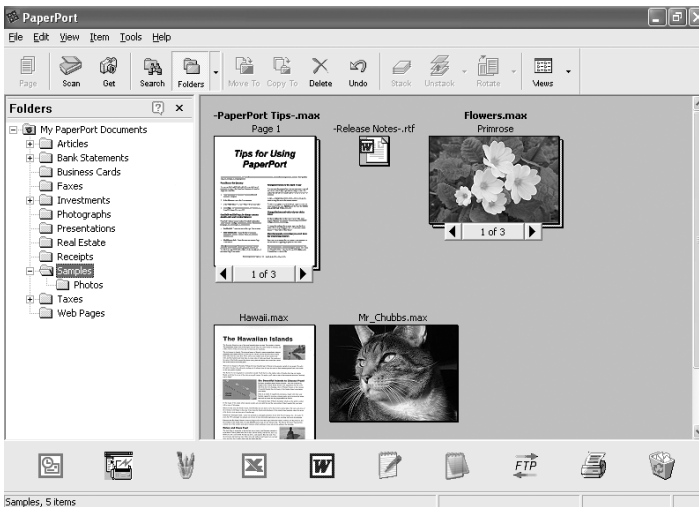

The complete ScanSoft™ PaperPort® Users Guide, including ScanSoft™ TextBridge® OCR, is in the On-Line documentation on the CD-ROM.

This chapter is only an introduction to the basic operations.

When you install Multi-Function Link® Pro, ScanSoft™ PaperPort® for Brother and ScanSoft™ TextBridge® OCR are installed with it automatically.

## Viewing items

ScanSoft™ PaperPort® provides several ways to view items:

**Desktop View** displays a thumbnail (a small graphic that represents each item in a Desktop or folder).

Items in the selected folder appear on the PaperPort® Desktop. You can see PaperPort® items (MAX files) and non-PaperPort® items (files created using other applications).

Non-PaperPort® items include an icon that indicates the application that was used to create the item; a non-PaperPort® item is represented by a small rectangular thumbnail and not an actual image.

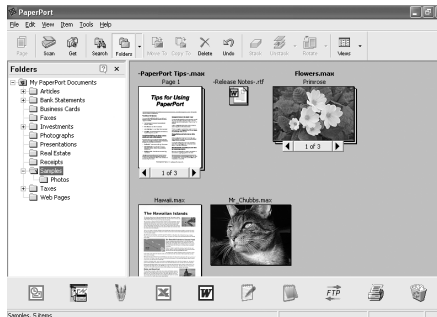

Desktop View displays items as thumbnails

**Page View** displays a close-up of a single page and you can open a PaperPort® item by double-clicking on it.

As long as you have the appropriate application on your computer to display it, you can also double-click a non-PaperPort® item to open it.

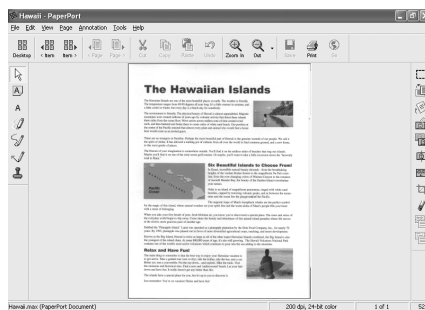

Page View displays each item as a full page

## Organizing your items in folders

PaperPort® has an easy-to-use filing system for organizing your items. The filing system consists of folders and items that you select to view in Desktop View. An item can be a PaperPort® item or a non-PaperPort® item:

- Folders are arranged in a “tree” structure in the Folder View. You use this section to select folders and view their items in Desktop View.
- You can simply drag and drop an item onto a folder. When the folder is highlighted, release the mouse button and the item is stored in that folder.
- Folders can be “nested”—that is, stored in other folders.
- When you double-click a folder, its items (both PaperPort® MAX files and non paperport® files) appear on the Desktop.
- You can also use Windows® Explorer to manage the folders and items shown in Desktop View.

## Quick links to other applications

ScanSoft™ PaperPort® automatically recognizes many other applications on your computer and creates a “working link” to them.

The Send To Bar at the bottom of the Desktop view shows icons of those linked applications.

To use a link, drag an item onto one of the icons to start the application represented by the icon. A typical use of the Send To Bar is to select an item and then fax it.

This sample Send To Bar shows several applications with links to PaperPort®.



If PaperPort® does not automatically recognize one of the applications on your computer, you can manually create a link using the **Add to Send To Bar...** command.

(See PaperPort® in the On-Line-Documentation on the CD-ROM for more information about creating new links.)



# ScanSoft™ TextBridge® OCR lets you convert image text in to text you can edit

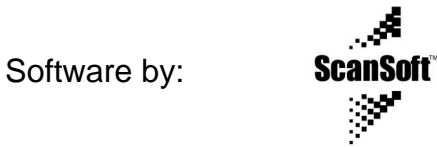

ScanSoft™ TextBridge® OCR is installed automatically with PaperPort® when you install Multi-Function Link® Pro on your computer.

ScanSoft™ PaperPort® can quickly convert the text on a ScanSoft™ PaperPort® item (which is really just a picture of the text) into text that you can edit with a word processing application.

PaperPort® uses the optical character recognition application ScanSoft™ TextBridge®, which comes with PaperPort®

—OR—

PaperPort® uses your application if it is already on your computer. You can convert the entire item, or by using the **Copy Text** command, you can select only a portion of the text to convert.

Dragging an item onto a word-processing link icon starts PaperPort®'s built-in OCR application, or you can use your own OCR application.



## You can Import items from other applications

In addition to scanning items, you can bring items into PaperPort® in a variety of ways and convert them to PaperPort® (MAX) files in several different ways:

- Print to the Desktop View from another application, such as Microsoft Excel.
- Import files saved in other file formats, such as Windows® Bitmap (BMP) or Tag Image File Format (TIFF).

## You can Export items in other formats

You can export or save PaperPort® items in several popular file formats, such as BMP, JPEG, TIFF, or self-viewing.

For example, to create a file for an Internet Web site, export it as a JPEG file. Web pages often use JPEG files for displaying images.

### Exporting an image file

- 1 Select the Save As command from the File pull-down menu in the PaperPort® window. The Save 'XXXXX' As dialog box will be displayed.
- 2 Select the drive and directory where you want to store the file.
- 3 Enter the new file name and choose the file type or select a name from the File Name text box. (You can scroll through the Directories and File Name listing for prompting.)
- 4 Select the OK button to save your file, or Cancel to return to the PaperPort® without saving it.



To Uninstall PaperPort® and ScanSoft™ TextBridge

For Windows® 98/98SE, Windows® Me and Windows® 2000 Professional:

Select **Start, Settings, Control Panel, Add/Remove Programs** and the **Install/Uninstall** tab.

Select **PaperPort® 8.0SE** from the list and click the **Add/Remove** button.

Select **Brother Extensions for Paperport** and click the **Add/Remove** button.

For Windows® XP:

Select **Start, Control Panel, Add or Remove Programs** and the **Change or Remove Programs** icon.

Select **PaperPort® 8.0SE** from the list and click the **Change** button.

# 18 Using Remote Setup

(For Windows® Only)

## MFC Remote Setup

The MFC Remote Setup application allows you to quickly set up your MFC by taking advantage of the ease and speed of programming on your PC. When you access this application, the settings on your MFC will be downloaded automatically to your PC and displayed on your computer screen. If you change the settings, you can upload them directly to the MFC.

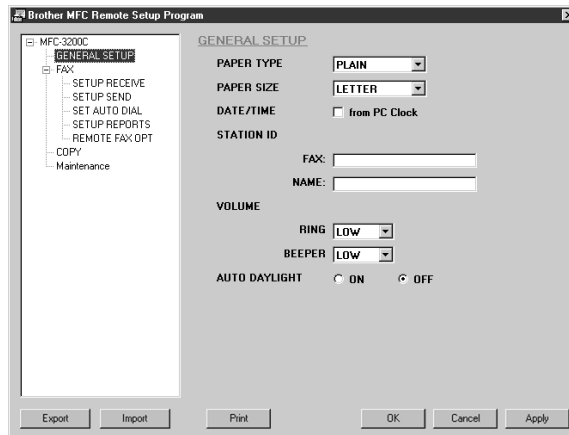

### **OK**

This starts the process of uploading the data to the MFC and exiting the remote setup program. If an error message is displayed enter the correct data again, then click **OK**.

### **Cancel**

This exits the remote setup application without uploading the data to the MFC.

### **Apply**

This uploads the data to the MFC, but does not exit the remote setup application.

### **Print**

This command prints the selected items on the MFC. You can not print the data until it is uploaded to the MFC. Click **Apply** to upload the new data to the MFC and click **Print**.

### **Export**

This command saves the current configuration settings to a file.

### **Import**

This command reads the settings from a file.



You can check the Ink Status in the Maintenance menu.

# 19 Using PC-FAX

(For Windows® Only)



## PC FAX Sending

The Brother PC FAX feature allows you to use your PC to send a file. You can create a file in any application on your PC, and then send it as a PC FAX. You can even attach a cover page note. All you have to do is set up the receiving parties as Members or Groups in your PC FAX Address Book. Then you can use the Address Book Search feature to quickly find them to address your fax.

 PC FAX is available in Black & White only.

### Setting Up User Information

- 1 From the **Start** menu, select **Programs**, **Brother**, **Brother MFL Pro Suite**, and then select **PC-FAX Setting**.

 You can access the User Information from the FAX Sending dialog box by clicking . (See *Sending a File as a PC-FAX Using the Facsimile Style*, page 19-12.)

The Brother PC Fax Setup dialog box will appear:

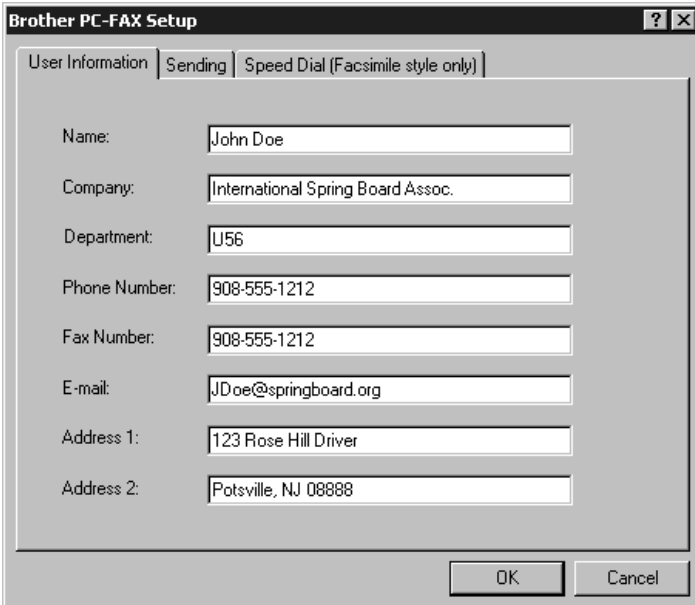

The screenshot shows the 'Brother PC-FAX Setup' dialog box with the 'User Information' tab selected. The fields are filled with the following data:

Field	Value
Name:	John Doe
Company:	International Spring Board Assoc.
Department:	U56
Phone Number:	908-555-1212
Fax Number:	908-555-1212
E-mail:	JDoe@springboard.org
Address 1:	123 Rose Hill Driver
Address 2:	Potsville, NJ 08888

Buttons for 'OK' and 'Cancel' are visible at the bottom right of the dialog box.

- 2 Enter the required User information. This information is required to create the Fax Header and Cover Page.
- 3 To save the User Information, click **OK**.

## Setting Up Sending

To access the Sending tab from the Brother PC-FAX Setup dialog box, click the **Sending** tab.

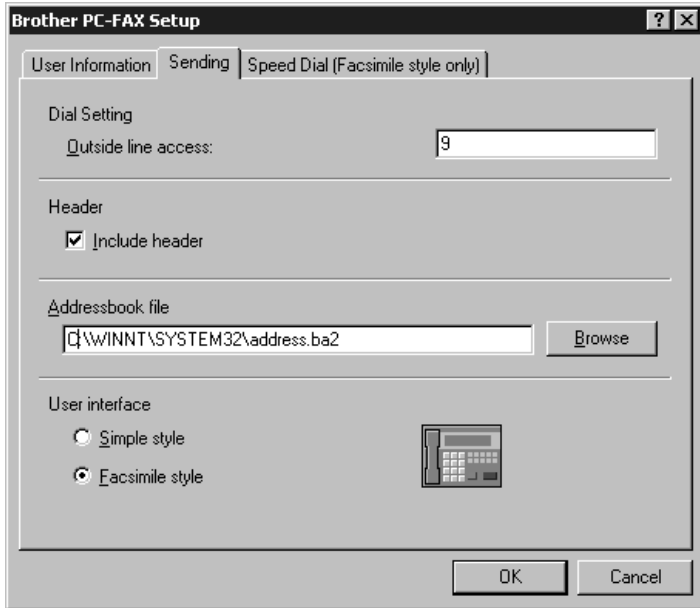

### Outside line access

Enter the number needed to access an outside line. This is sometimes required by the local PBX telephone system.

### Include header

To add header information to the top of the fax pages being sent, check the Header box.

### Address Book file

You can select different database files for use with the Address Book. You must enter the path and file name of the database file or use the Browse button to view the file system to select the file.

## User interface

Select the User Interface in the Sending tab. You have a choice of the Simple Style or the Facsimile Style.

### Simple Style

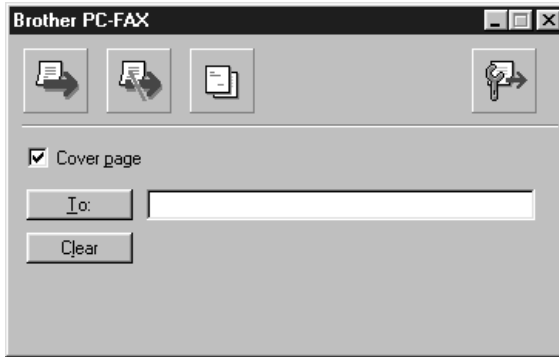

### Facsimile Style



## Setting Up Speed Dial

Access the Speed Dial tab from the Brother PC-FAX Setup dialog box by clicking the **Speed Dial** tab. (To use this feature you must select the Facsimile Style user interface.)

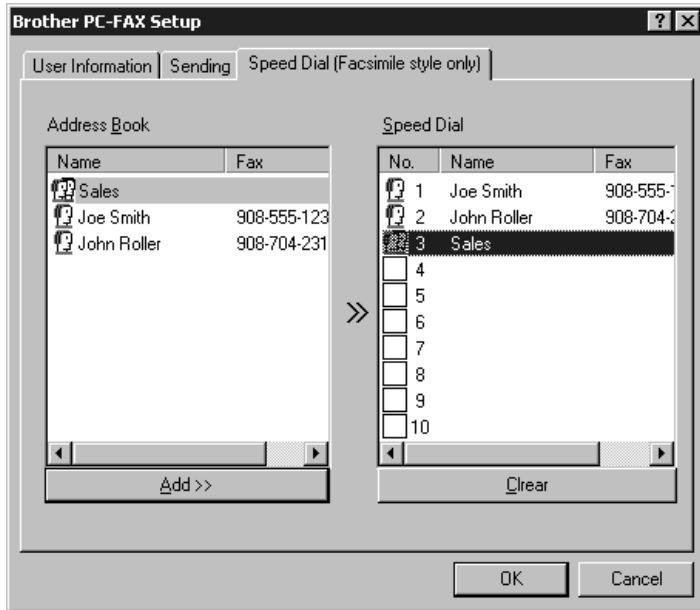

You can register any address or group on one of the ten Speed Dial buttons.

To register an address in a Speed Dial location:

- 1 Click the Speed Dial location you want to program.
- 2 Click the address or group you wish to assign to the Speed Dial location.
- 3 Click **Add >>** to program the Speed Dial location.

To clear a Speed Dial location:

- 1 Click the Speed Dial location you want to clear.
- 2 Click **Clear**.

## The Address Book

From the **Start** menu, select **Programs, Brother, Brother MFL Pro Suite**, and then click **Address Book**.

The Brother Address Book dialog box will appear:

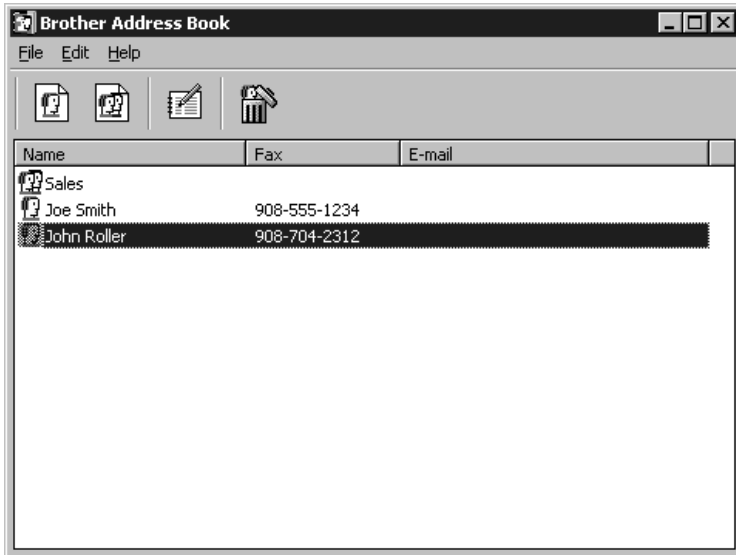



## Setting Up a Member in the Address Book

In the Brother Address Book dialog box you can add, edit and delete stored information for members and groups.

- 1 In the Address Book dialog box, click the  icon to add a member. The Brother Address Book Member Setup dialog box will appear:

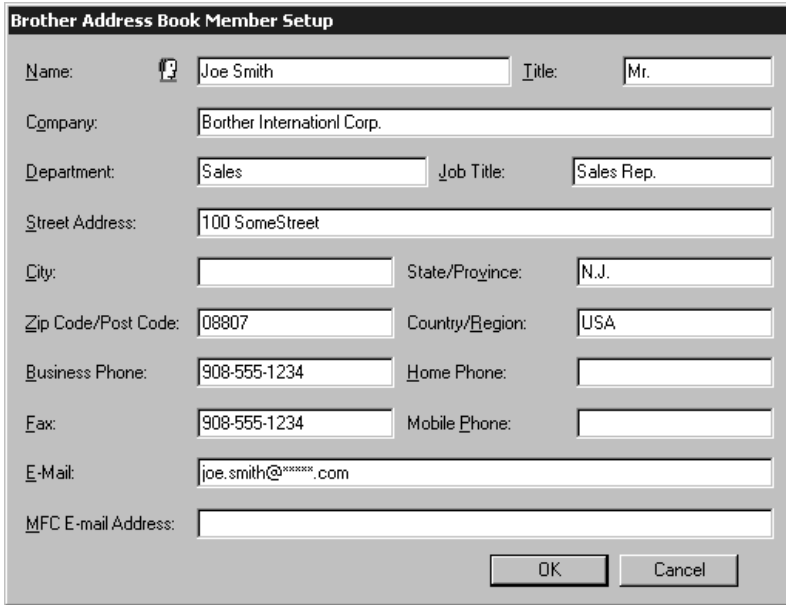

**Brother Address Book Member Setup**

Name:  Title:

Company:

Department:  Job Title:

Street Address:

City:  State/Province:

Zip Code/Post Code:  Country/Region:

Business Phone:  Home Phone:

Fax:  Mobile Phone:

E-Mail:

MFC E-mail Address:

OK Cancel

- 2 In the Brother Address Book Member Setup dialog box, type the member's information. **Name** and **Fax** are required fields. Click **OK** to save the member's information.

## Setting Up a Group for Broadcasting

If you repeatedly send the same PC-FAX to multiple recipients, you can combine members into a Group.

- 1 In the Brother Address Book dialog box, click the  icon to create a group. The Brother Address Book Group Setup dialog box appears:

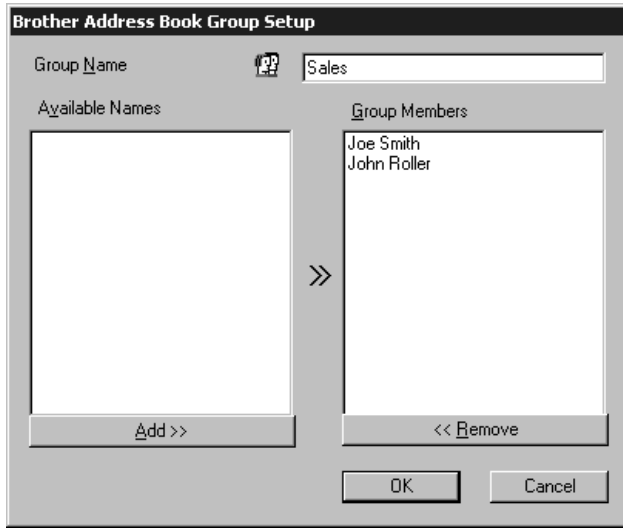

- 2 Type the name of the new group in the **Group Name** field.
- 3 In the **Available Names** box, select each member to be included in the Group, and then click **Add >>**. Members you add to the group will be listed in the Group Members box.
- 4 After all the members have been added, click **OK**.

## Editing Member Information

- 1 Select the Member or Group you want to edit.
- 2 Click the edit  icon.
- 3 Edit the Member or Group information.
- 4 Click **OK** to save your changes.

## Deleting a Member or Group

- 1 Select the Member or Group you want to delete.
- 2 Click the delete  icon.
- 3 Click **OK** when the Delete OK? Dialog box appears.

## Exporting the Address Book

You can export the Address Book to an ASCII text file (\*.csv). If you wish, you can create a Vcard for selected members that will be attached to all the sender's outgoing E-mail; a Vcard is an electronic business card that contains the sender's contact information.

### To export the current telephone book:

 If you are creating a Vcard, you must first select the member.

- 1 From the Address Book select **File**, point to **Export**, and then click **Text**—**OR**—Click **Vcard** and go to Step 5.
- 2 Select the data fields you wish to Export from the **Available Items** column, and then click **Add >>**.

 Select items in the order you want them listed.

- 3 If you are exporting to an ASCII file, select **Divide Character - Tab** or **Comma**. This selection inserts a Tab or Comma between each data field when it is Exported.
- 4 Select **OK** to save the data.

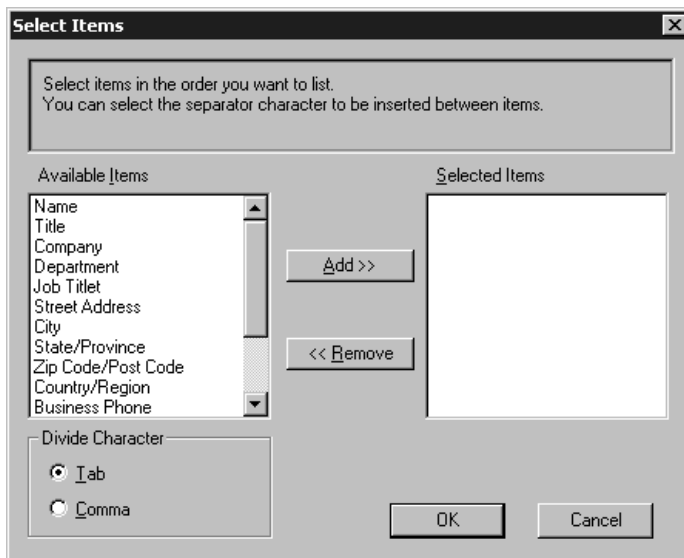

- 5 Type the name of the file, and then select **Save**.

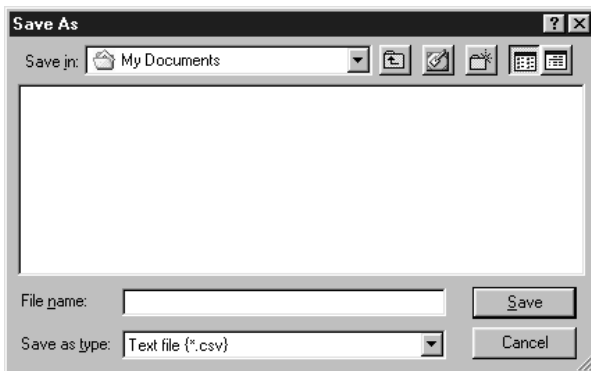

**Note** If you selected Vcard in Step 1, the **Save as type:** will be **Vcard (\*.vcf)**.

## Importing to the Address Book

You can import ASCII text files (\*.csv) or Vcards (electronic business cards) into your Address Book.

### To import an ASCII text file:

- 1 From the Address Book select **File**, point to **Import**, and then click **Text**—**OR**—Click **Vcard** and go to Step 5.

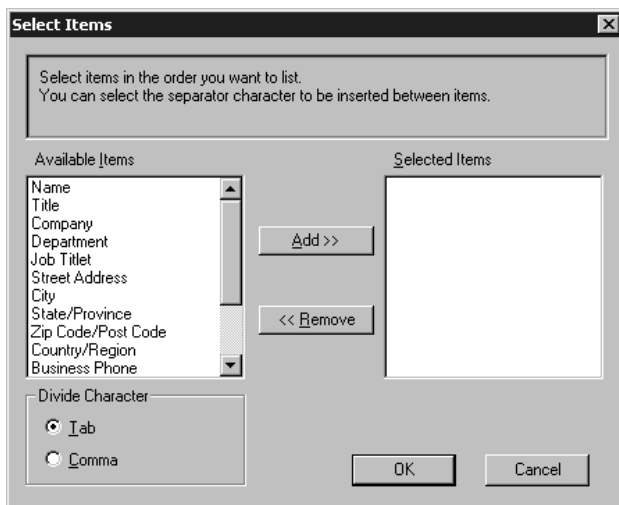



- 2 Select the data fields you wish to Import from the **Available Items** column, and then click **Add >>**.

**Note** Select the fields from the Available Items list in the same order they are listed in the Import text file.

- 3 Select **Divide Character - Tab** or **Comma** based on what file format you are importing.

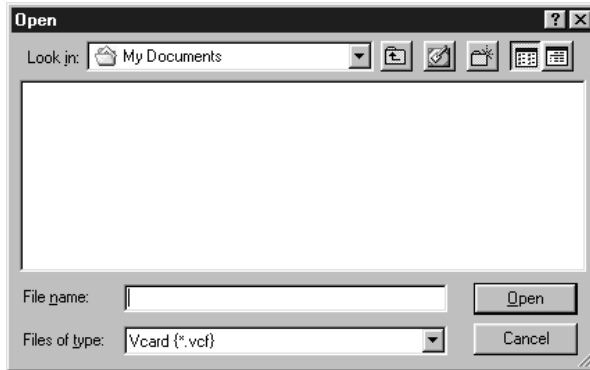
- 4 Select **OK** to import the data.
- 5 Type the name of the file, and then select **Open**.



 If you selected a text file in Step 1, the **Files of type:** will be **Text file (\*.csv)**.

## Setting Up a Cover Page

Access the Brother PC-FAX Cover Page Setup from the FAX Sending dialog box by clicking . (See *Sending a File as a PC-FAX Using the Facsimile Style*, page 19-12.)

The Brother PC-FAX Cover Page Setup dialog box will appear:

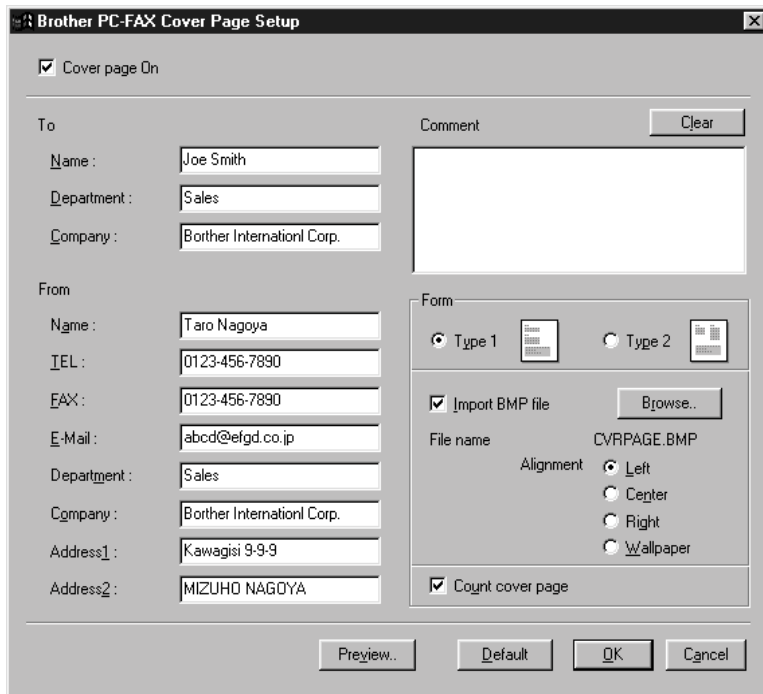

## **To**

You can enter information in each field.



If you are sending a fax to multiple recipients, the recipient information will not be printed on the Cover Page.

## **From**

You can enter information in each field.

## **Comment**

Type the comment you want to add to the cover page.

## **Select Cover Page Form**

Select the cover page form you want.

## **Import BMP file**

You can insert a bitmap file, such as your company logo, in the cover page.

Select the BMP file by using the browse button, and then select the alignment style.

## **Count Cover Page**

When the Count Cover Page box is checked, the Cover Page will be included in the page numbering. When this box is not checked, the Cover Page will not be included.

## Sending a File as a PC-FAX Using the Facsimile Style

- 1 Create a file in Word, Excel, Paint, Draw or any other application on your PC.
- 2 From the **File** menu, select **Print**.  
The Print dialog box will appear:

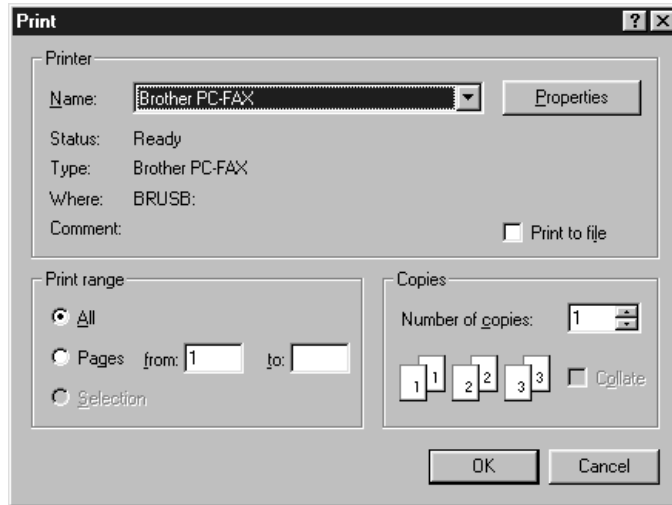

- 3 Select **Brother PC-FAX** as your printer, and then click **OK**.  
The FAX Sending dialog box will appear:



- 4 Enter the fax number by using any of the following methods:
  - a. Enter the number using the dial pad.
  - b. Click any of the 10 **Speed Dial** buttons.
  - c. Click the **Address Book** button, and then select a Member or Group from the Address Book.

 If you make a mistake you can use the click **Clear** to clear all the entries.

- 5 To include a cover page, click  **Cover Page On**, and then click the Cover

Page  icon to enter or edit the cover page information.

- 6 Click **Start** to send the fax.

 If you wish to cancel the fax, click **Stop**.

## Redial

If you want to redial a number, click **Redial** to scroll through the last five fax numbers, and then click **Start**.

## Sending a File as a PC-FAX Using the Simple Style

- 1 Create a file in Word, Excel, Paint, Draw or any other application on your PC.
- 2 From the **File** menu, select **Print**.

The Print dialog box will appear:

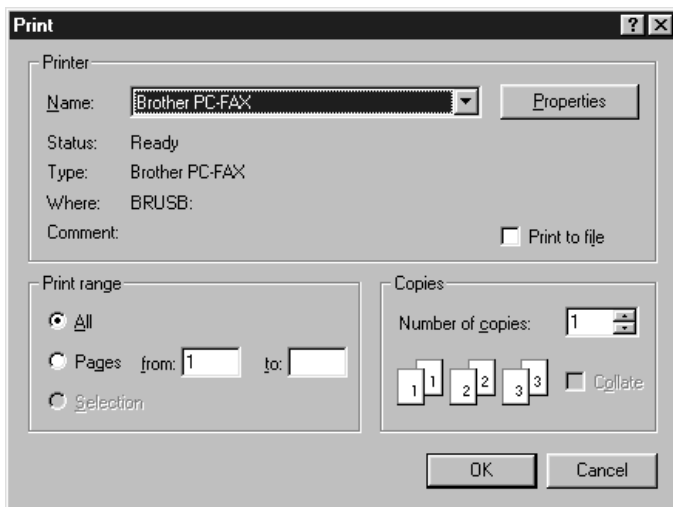



- 3 Select **Brother PC-FAX** as your printer, and then click **OK**.

The FAX Sending dialog box will appear:

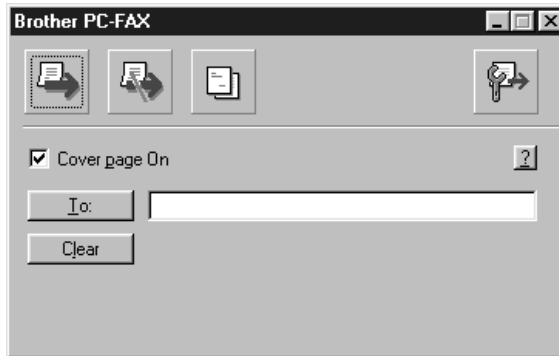

- 4 In the **To:** field, type the fax number of the receiving party. You can also use the Address Book to select destination fax numbers. If you made a mistake entering a number, click the **Clear** button to clear all entries.
- 5 To send a Cover Page and note, check the **Cover Page On** check box.



You can also click the  to create or edit an existing cover page.

- 6 When you are ready to send your fax, click the Send  icon.

- 7 If you wish to cancel the fax, click the  icon.

# 20 Using Automatic E-Mail Printing

**For Windows® 98, 98SE, Me only**

---

## Main Features

- You can use Automatic E-Mail Printing with other E-mail software: Brother Automatic E-Mail Printing has some extra functions that other E-mail software, such as Netscape Navigator™ or MS Internet Mail, do not support.
- Automatic E-Mail Printing can be configured for a multiple user account: In Brother Automatic E-Mail Printing you can set up more than one E-mail account on a single PC so you can print E-mail in each account automatically.
- Automatic access to your specified POP3 server at the specified time: You can specify the time when the Brother Automatic E-Mail Printing automatically accesses the server to check for new mail.
- Provides an “In Memory” printer driver: You can receive and print E-mail data at the same time, by searching for a specified character string in the mail header. It allows you to see the sender, subject and relevant part of the mail content.

## Before You Use this Software

Please read *Using Automatic E-Mail Printing* in the **On-Line Documentation** on the CD-ROM. Check the online README.WRI file in the root directory of the CD-ROM for last-minute important information and troubleshooting tips not included in the On-Line Documentation.

## To Access the On-Line Documentation



After you have installed the Brother driver(s) for your model and operating system, click **View On-Line Documentation** for operating instructions.

## To Install Automatic E-mail Printing (Optional Application):

- 1 Insert MFL Pro CD-ROM into your CD-ROM drive.
- 2 Click on **Install Software** from the main CD-ROM screen.
- 3 Click **Automatic E-mail Printing**.



*This is optional software and will not be required for printing, faxing and scanning operations.*

**The Automatic E-mail Print option is NOT available for Windows® 2000 Professional and XP.**

# 21 Using the Brother MFC with a New Power Macintosh® G3, G4 or iMac™/iBook™

## Set Up Your USB-Equipped Apple® Macintosh® G3, G4 or iMac™ or iBook™ with Mac OS 8.5-9.2 or Mac OS X v.10.1

**Note** Before you can connect the MFC to your Macintosh®, you must purchase a USB cable that is no longer than 6 feet (1.8 meters).

To work with your MFC, your USB-Equipped Apple® Macintosh® must be set up with Mac OS 8.5-9.2 (The Brother Scanner driver and PC FAX Send driver work only with Mac OS 8.6-9.2)

## Using Brother Printer Driver with Your Apple® Macintosh® (OS 8.5-9.2)

To select the Printer:

- 1 From the Apple menu, open the **Chooser**.

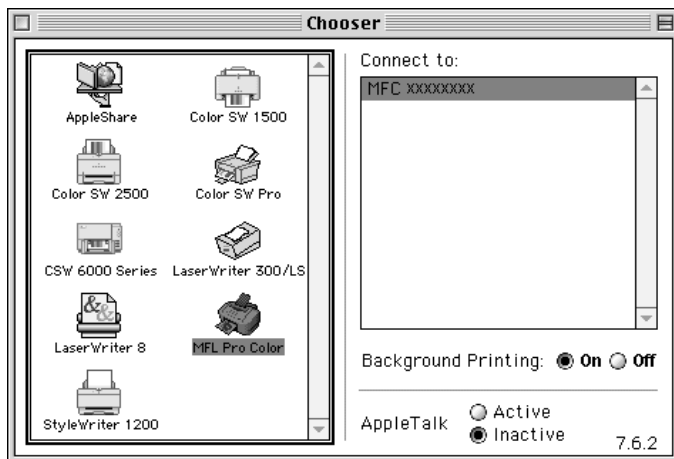

- 2 Click the **MFL Pro Color** icon. On the right side of the Chooser, click the printer to which you want to print. Close the Chooser.

### To print the document:

- 3 From application software such as PaperPort®, click *File menu* and select *Page Setup*. You can change the settings for **Paper Size**, **Paper Thickness**, **Paper Source**, **Orientation**, and **Scaling**, then click **OK**.

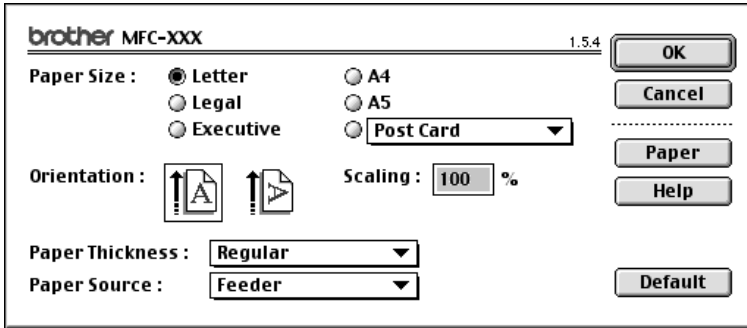

- 4 From application software such as PaperPort, click *File menu* and select *Print*. Click **Print** to start printing.

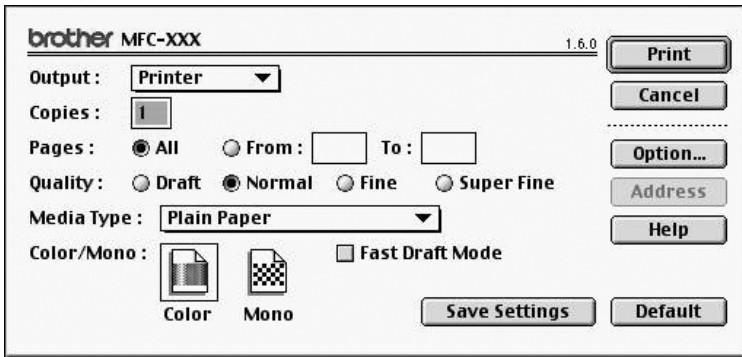

**Note** If you want to change **Copies**, **Pages**, **Quality**, **Media Type** and **Color/Mono**, select your settings before clicking **Print**.

Option Setup allows you to change **Document** and **Printing Options**.

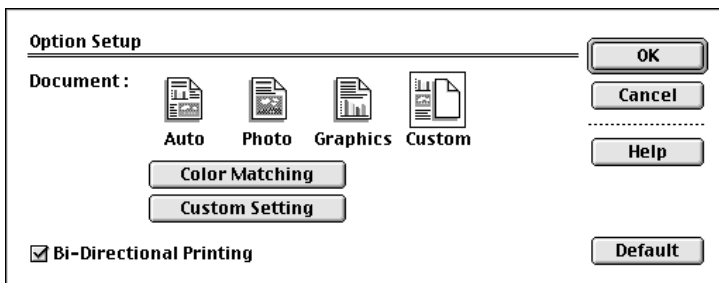

# Using Brother Printer Driver with Your Apple<sup>®</sup> Macintosh<sup>®</sup> (OS X v.10.1)

---

## Choosing page setup options

From application software such as TextEdit, click **File** menu and select **Page Setup**. Make sure **MFC-3200C** is selected in the **Format for** pop-up menu. You can change the settings for **Paper Size**, **Orientation** and **Scaling**, then click **OK**.

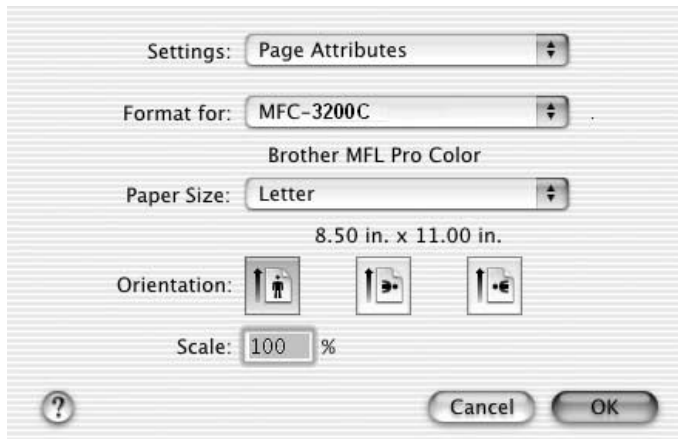

## Printing a document

From application software such as TextEdit, click **File** menu. When the print dialog appears, then click **Print**.

Make sure **MFC-3200C** is selected in the **Printer** pop-up menu.

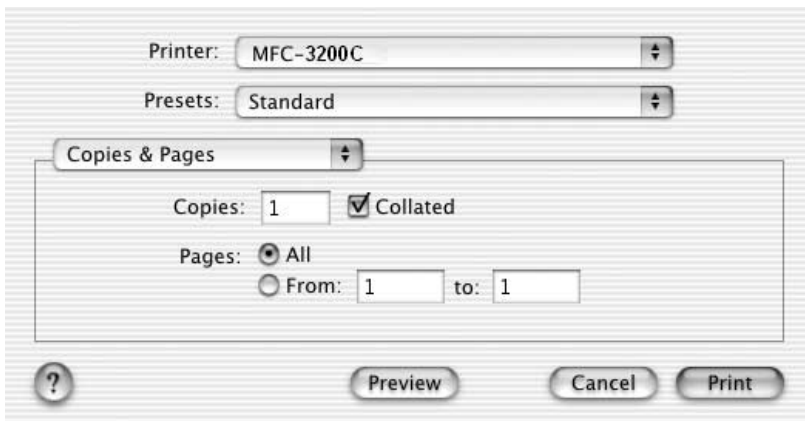

## Choosing printing options

If you want to print multiple copies, a specific range of pages, or multiple pages on a single sheet of paper, or to control the special printing features of a printer or application, choose options in the Print dialog.

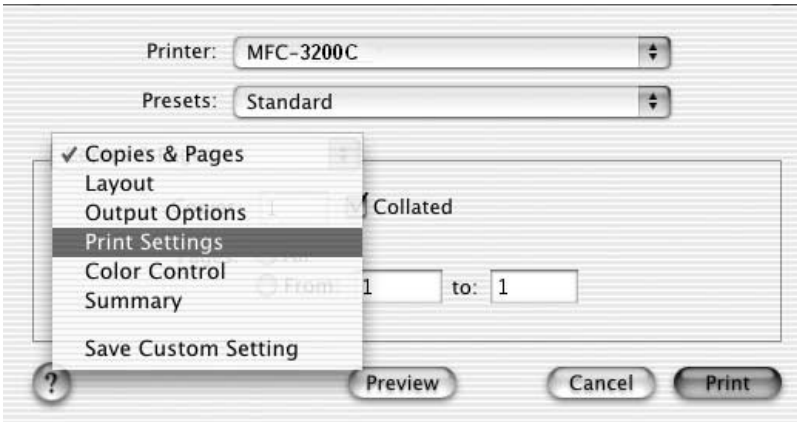

# Sending a Fax from Your Macintosh® Application (For OS 8.5-9.2)

You can send a fax directly from your Macintosh® application using the following steps:

- 1 Create a document in a Macintosh application.
- 2 To begin the fax transmission, select **Print** from the **File** menu. The Printer dialog box appears:

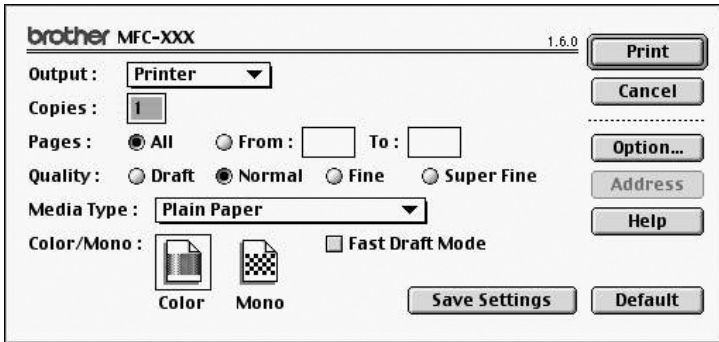

When **Printer** is selected, the top button shows **Print** and the **Address** button is grayed.

- 3 From the **Output** pull-down menu, select **Facsimile**.

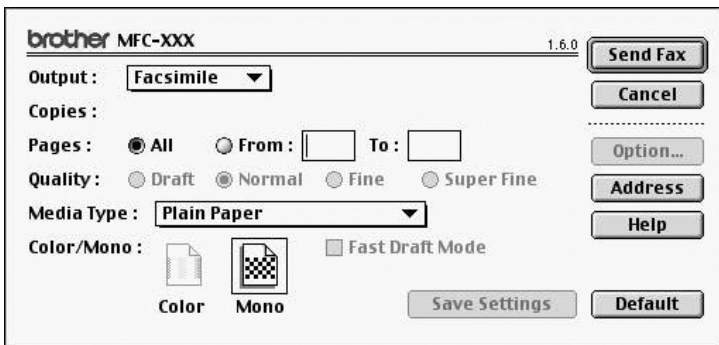

When **Facsimile** is selected, the top button shows **Send Fax** and the **Address** button is available.

4 Click **Send Fax**.

The Send Fax dialog box appears:

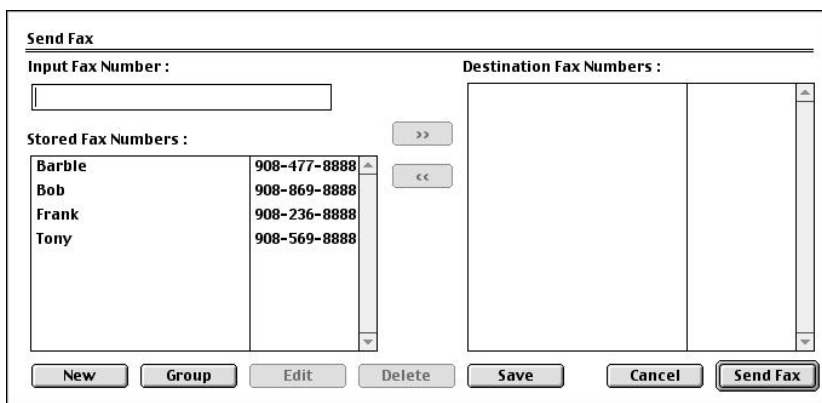

The Send Fax dialog box has two list boxes. The left box shows all the previously **Stored Fax Numbers**; the right box will show the **Destination Fax Numbers** as you select them.

5 To address the fax, type a fax number in the **Input Fax Number** box.

—OR—

Select a name/number from the **Stored Fax Numbers** box, and then click . Your recipient will appear in the **Destination Fax Numbers** box.



You can select several stored numbers at once by using the Shift and Ctrl keys.

6 If you want to, you can add your new recipients to the Stored Fax Number at this time by clicking **New**. (See *Adding a New Member*, page 21-7.)

—OR—

You can add a new group by clicking **Group**. (See *Adding a New Group*, page 21-8.)

7 If you are finished addressing your fax, click **Send Fax**.



To select and send only certain pages of the document, click **OK** to return to the Print dialog box.



If you click **Send Fax** without addressing your fax, the following error message appears:

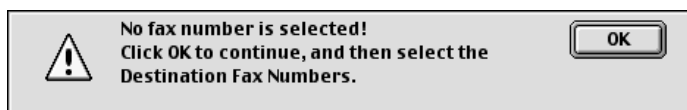

Click **OK** to return to the Send Fax dialog box.



## Setting Up Your Address Book

You can add new members and groups to your Address Book, even while you are addressing a fax.

### Adding a New Member

- 1 To add a new member to the Address Book, in the Facsimile dialog box click **Address**.

The Address Book dialog box appears:

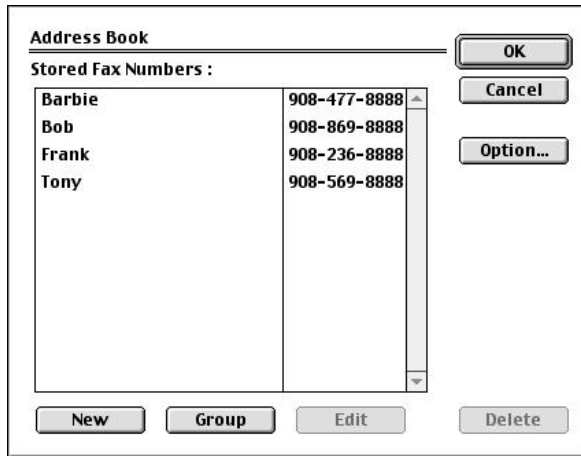

The Address Book dialog box is titled "Address Book". It features a list of "Stored Fax Numbers" with the following entries:

Barbie	908-477-8888
Bob	908-869-8888
Frank	908-236-8888
Tony	908-569-8888

At the bottom of the dialog box are four buttons: "New", "Group", "Edit", and "Delete". On the right side, there are three buttons: "OK", "Cancel", and "Option...".

- 2 Click **New**. The following dialog box appears:

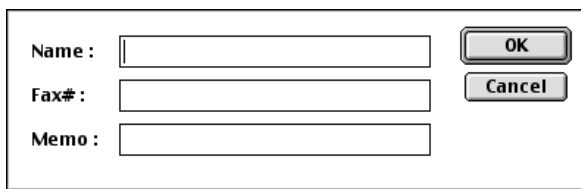

The New Member dialog box contains three input fields and two buttons:

- Name :** [Text Input Field]
- Fax# :** [Text Input Field]
- Memo :** [Text Input Field]

On the right side, there are two buttons: "OK" and "Cancel".

- 3 Type the name and fax number.
- 4 If you want to, you can store a comment in the Memo field if you wish (up to 15 characters).
- 5 Click **OK** to return to the Address Book dialog box.

## Adding a New Group

You can set up a group of multiple recipients.

**1** Click **Group**.

The Group Setting dialog box appears.

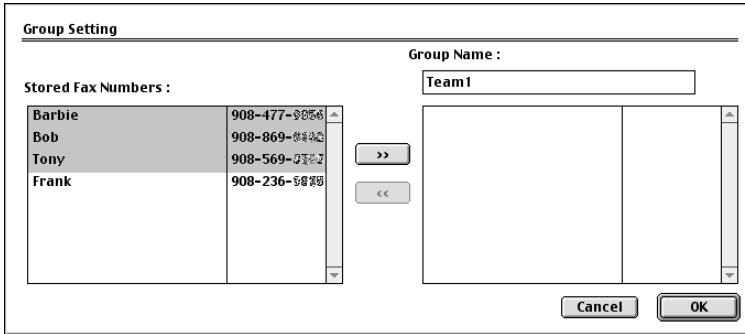

**2** In the *Group Name* field, type a name for your Group.

**3** From the **Stored Fax Numbers** box select the recipients for your Group, and then click .

Your selection will appear in the box under the **Group Name** field.

**4** Click **OK**.

The Address Book dialog box reappears:

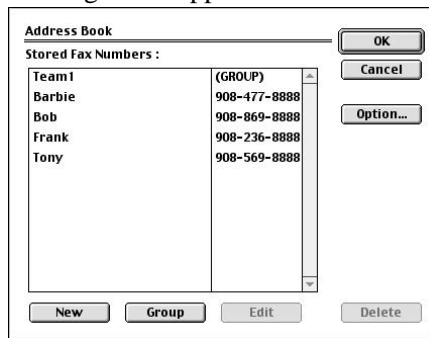

**5** Click **OK**.

The Print/Facsimile dialog box reappears:

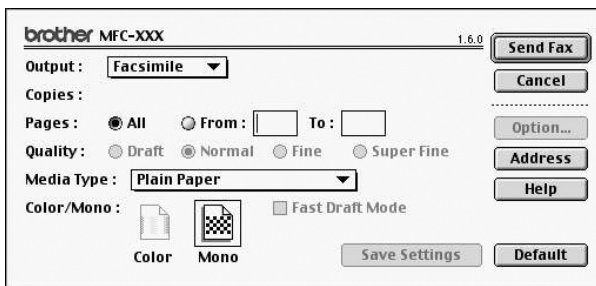

**6** If you are ready to send your fax, click **Send Fax**.  
(Follow the steps on page 21-5 for sending a fax.)

# Using Brother TWAIN Scanner Driver with Your Apple® Macintosh® (For OS 8.6-9.2)

The Brother MFC software includes a TWAIN Scanner driver for Macintosh®. This Macintosh® TWAIN Scanner driver can be used with applications that support the TWAIN specification. You can use PaperPort® for scanning.

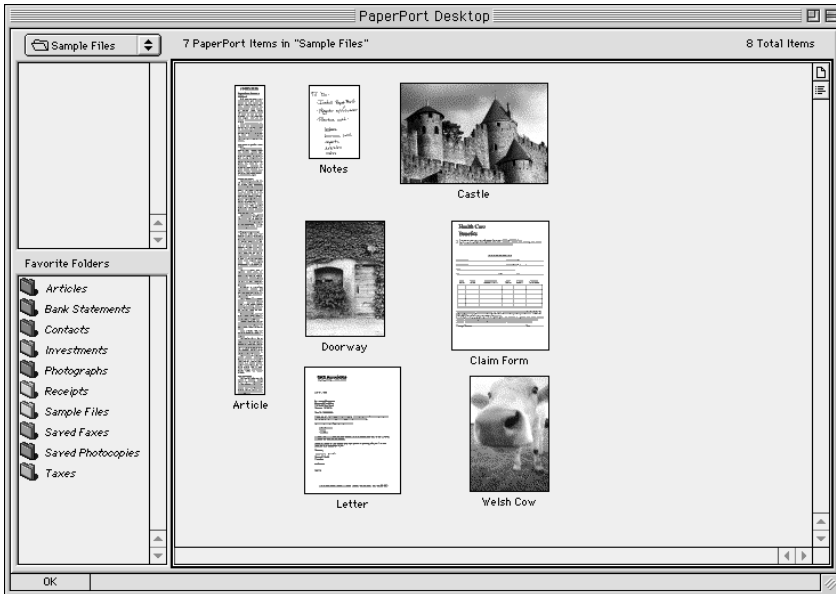

## Accessing the Scanner

Run your PaperPort® software. You will see the **PaperPort® icon** in the upper right hand corner of your screen. The first time you use the Brother TWAIN driver, set it as the default by choosing the *Select Source*, then click the **PaperPort® icon**. Afterward, for each original you scan choose **Acquire Image** by clicking the **PaperPort® icon**. The Scanner setup dialog box will appear.

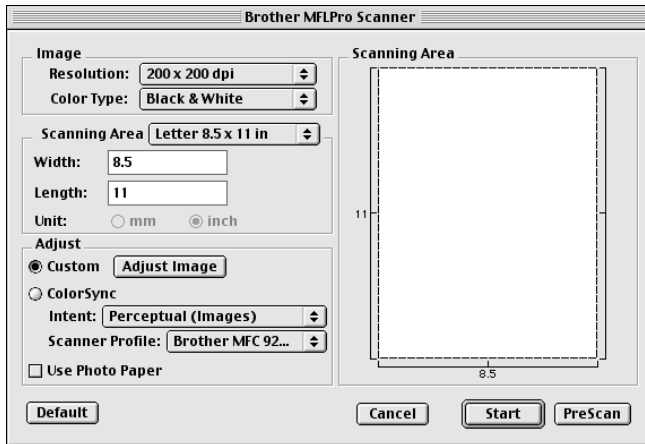

If you are using PaperPort® 5.5 for Mac, from the ScanSoft menu (located below the ScanSoft icon on the Macintosh desktop menu bar), choose **Acquire Image**. For details about the ScanSoft menu selections, please see the PaperPort® Online Documentation located in the PaperPort® 5.5 Folder/User Docs/Splashug.pdf file.

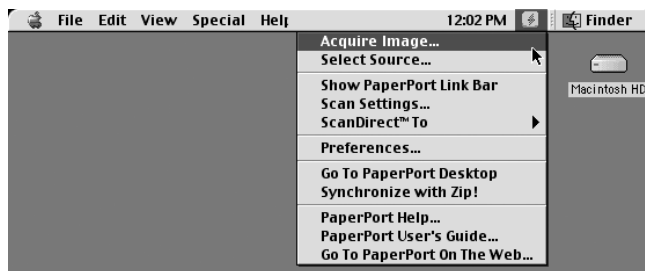

## Scanning a Document into Your Macintosh G3, G4 or iMac

- 1 Place the original in the ADF.
- 2 Adjust the following settings, if needed, in the scanner setup dialog box:
  - Resolution*
  - Color Type*
  - Brightness*
  - Contrast*
  - Scanning Area*
- 3 Click **Start**.

When scanning is finished, the image will appear in your graphics application.

### Settings in the Scanner Window

#### Image

##### *Resolution*

Choose the scanning resolution from the Resolution pop-up menu. Higher resolutions take more memory and transfer time, but can achieve a finer scanned image. (Each model has different resolutions. See Specification.)

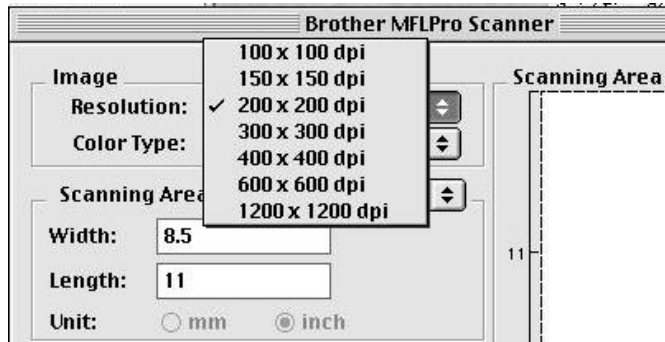

##### *Color Type*

*Black & White*—Set the image Type to Black&White for text or line art. For photographic images, set the image type to Gray (Error diffusion) or True Gray.

*Gray (Error Diffusion)*—is used for documents that contain photographic images or graphics. (Error Diffusion is a method for creating simulated gray images by placing black dots in a specific matrix instead of true gray dots.)

*True Gray*—also is used for documents containing photographic images or graphics. This mode is more exact because it uses up to 256 shades of gray. It requires the most memory and longest transfer time.

*Colors*—Choose either 256 Color, which scans up to 256 colors, 24-bit color which scans up to 16.8 million colors. Although using 24-bit color creates an image with the most accurate colors, the image file will be approximately three times larger than a file created with 256 Color.

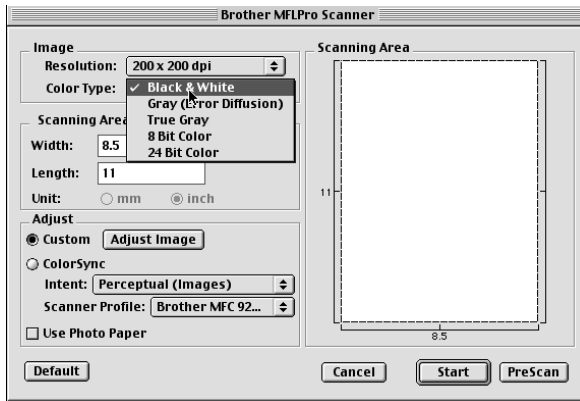

## Scanning Area

Set the **Size** to one of the following:

- *Letter* (8.5 × 11 inches)
- *A4* (210 × 297 mm)
- *Legal* (8.5 × 14 inches)
- *A5* (148 × 210 mm)
- *B5* (182 × 257 mm)
- *Executive* (7.25 × 10.5 inches)
- *Business Card* (90 × 60 mm)
- *Custom* (User adjustable from 0.35 × 0.35 inches to 8.5 × 14 inches)

After you choose a custom size, you can adjust the scanning area. Click and hold the mouse button as you drag the mouse to crop the image.

**Width:** Enter the width of the custom size.

**Length:** Enter the length of the custom size.

## Business Card Size

To scan business cards, select the Business Card size setting (90 × 60 mm) and place the business card at the top center of a carrier sheet.



Carrier sheets are available from your Dealer.

When scanning photographs or other images for use in a word processor or other graphics application, it is a good idea to try different settings for the contrast, mode and resolution to determine which settings look best.

## Miscellaneous

### *Brightness*

Adjust the brightness settings to obtain the best image. The Brother TWAIN Scanner driver offers 100 brightness settings (-50 to 50). The default value is 0, representing an “average” setting.

You can set the brightness level by dragging the sidebar to the right to lighten the image or to the left to darken the image. You can also type a value in the box to set the setting. Click **OK**.

If the scanned image is too light, set a lower brightness value and scan the document again.

If the image is too dark, set a higher brightness value and scan the document again.

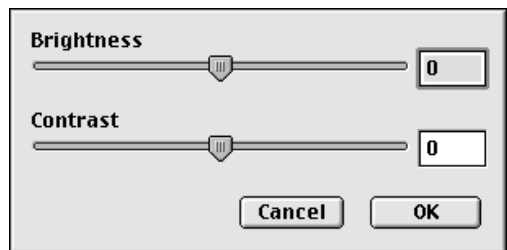

### **Contrast**

The contrast setting is adjustable only when you have selected one of the gray scale settings, but it is not available when Black & White is selected as the Gray Scale.

Increasing the contrast level (by dragging the sidebar to the right) emphasizes dark and light areas of the Image, while decreasing the contrast level (by dragging the sidebar to the left) reveals more detail in gray areas. Instead of using the sidebar, you can type a value in the box to set the contrast. Click **OK**.

## Color Sync Dialog

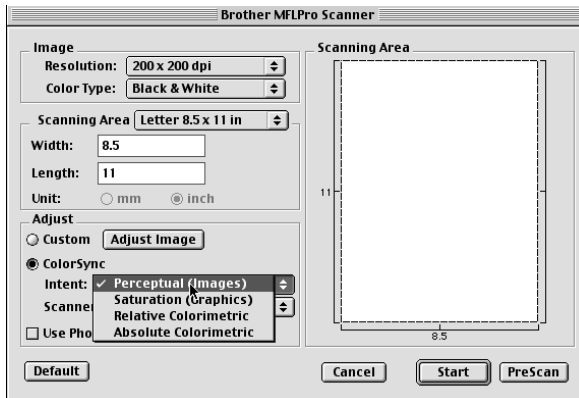

*Perceptual Matching*—All the colors of a given gamut are scaled proportionally to fit within another gamut. This intent pretty much maintains the balance between the colors in the image. This intent is the best choice for realistic images, such as scanned photographs.

*Saturation Matching*—The relative saturation of colors is maintained from gamut to gamut. So basically the colors are shifted to the edge of the gamut to get the most saturated color possible. Rendering the image using this intent gives the strongest colors and is the best choice for bar graphs and pie charts, in which the actual color displayed is less important than its vividness.

*Relative Colorimetric Matching*—The colors that fall within the gamuts of both devices are left unchanged. Some colors in both images will be exactly the same, a useful outcome when colors must match quantitatively. What that means is that if the color is inside the gamut, it will stay the same color. However, if the color is outside the gamut, it will be mapped to the edge of the gamut. This intent is best suited for logos or “spot colors” where color must match.

*Absolute Colorimetric Matching*—A close appearance match may be achieved over most of the tonal range, but if the minimum density of the idealized image is different from that of the output image, the areas of the image that are left blank will be different. Colors that fall within the gamuts of both devices are left unchanged.



## Scanner Profile

Select your Brother MFC.

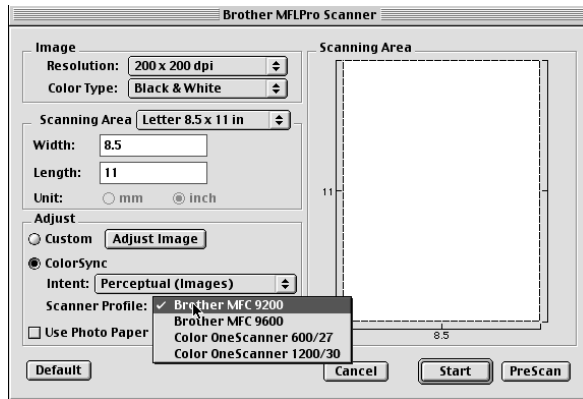

## PreScanning an Image

PreScanning allows you to scan an image quickly at a low resolution. A thumbnail version will appear in the Scanning Area. This is only a preview of the image, so you can see how it will look. The PreScan button is used to preview an image for cropping any unwanted portions from the image. When you are satisfied with the preview, click **Start** to scan the image.

1 Insert the original face down in the ADF.

2 Click **PreScan**.

The entire original will be scanned into your Macintosh G3 or iMac and will appear in the Scanning Area of the Scanner dialog box:

3 To scan a portion of the prescanned image, click and drag the mouse to crop it.

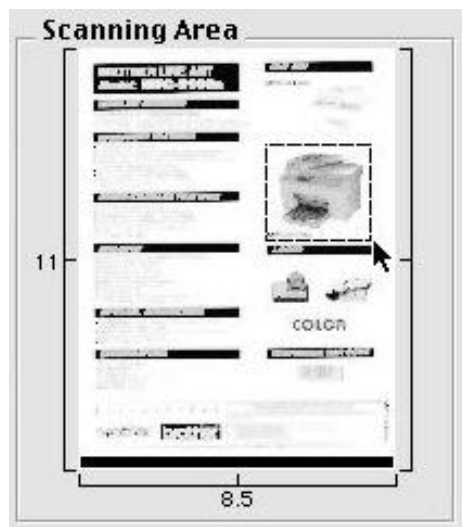

- 4 Insert original in the ADF of the Brother MFC again.
- 5 Adjust the settings for Resolution, Color Type (Gray Scale), Brightness, Contrast, and Size in the Scanner Setup dialog box, as needed.
- 6 Click **Start**.  
This time only the selected area of the original will appear in the Scanning Area.
- 7 In your editing software application, refine the image as usual.

# 22 Important Information

## ***Standard Telephone and FCC Notices***

---

**These notices are in effect on models sold and used in the United States only.**

**This equipment is hearing aid compatible.**

**When programming emergency numbers and/or making test calls to emergency numbers:**

- Remain on the line and briefly explain to the dispatcher the reason for the call before hanging up.
- Perform these activities in the off-peak hours, such as early morning or late evening.

This equipment complies with Part 68 of FCC Rules. On the rear panel of this equipment is a label that contains, among other information, the FCC Registration Number and Ringer Equivalence Number (REN) for this equipment. You must, upon request, provide this information to your telephone company.

You may safely connect this equipment to the telephone line by means of a standard modular jack, USOC RJ11C.

An FCC compliant telephone cord with a modular plug is provided with this equipment. This equipment is designed to be connected to the telephone line or premises wiring using a compatible modular jack that is Part 68 compliant. See the Installation section of this manual for details.

The REN is useful to determine the quantity of devices you may connect to your telephone line and still have those devices ring when your telephone number is called. In most, but not all areas, the sum of the RENs of all devices connected to one line should not exceed five (5). To be certain of the number of devices you may connect to your line, as determined by the REN, you should contact your local telephone company to determine the maximum REN for your calling area. If your MFC-3200C damages the telephone line, the telephone company may discontinue your service temporarily. If possible, they will notify you in advance. But if advanced notice is not practical, you will be notified as soon as possible. You will be informed of your right to file a complaint with the FCC.

Your telephone company may make changes to its facilities, equipment, operations or procedures that could affect the proper functioning of your equipment. If they do, you will be notified in advance to give you an opportunity to maintain uninterrupted telephone service.

If you experience trouble with your MFC-3200C, please contact a Brother Authorized Service Center for information on obtaining service or repair. The telephone company may ask that you disconnect this equipment from the line until the problem has been corrected or until you are sure that the equipment is not malfunctioning.

If you are not able to solve a problem with your MFC, contact Brother Customer Service. (See *Brother Numbers*, page i.)

## **WARNING**

For protection against the risk of electrical shock, always disconnect all cables from the wall outlet before servicing, modifying or installing the equipment.

This equipment may not be used on coin service lines provided by the telephone company or connected to party lines.

Brother cannot accept any financial or other responsibilities that may be the result of your use of this information, including direct, special or consequential damages. There are no warranties extended or granted by this document.

## **WARNING**

### **Important—About the Interface Cable**

This machine has been certified to comply with FCC standards, which are applied to the USA only. The filter core supplied with your MFC should be attached to the shielded interface cable according to FCC 15,27 (a). In addition, a grounded plug should be plugged into a grounded AC outlet after checking the rating of the local power supply for the printer to operate properly and safely.

## **Federal Communications Commission (FCC) Declaration of Conformity (For USA Only)**

Responsible Party:	Brother International Corporation 100 Somerset Corporate Boulevard Bridgewater, NJ 08807-0911 USA TEL: (908) 704-1700
--------------------	--

declares, that the products

Product Name: MFC-3200C

comply with Part 15 of the FCC Rules. Operation is subject to the following two conditions: (1) This device may not cause harmful interference, and (2) this device must accept any interference received, including interference that may cause undesired operation.

This equipment has been tested and found to comply with the limits for a Class B digital device, pursuant to Part 15 of the FCC Rules. These limits are designed to provide reasonable protection against harmful interference in a residential installation. This equipment generates, uses, and can radiate radio frequency energy and, if not installed and used in accordance with the instructions, may cause harmful interference to radio communications. However, there is no guarantee that interference will not occur in a particular installation. If this equipment does cause harmful interference to radio or television reception, which can be determined by turning the equipment off and on, the user is encouraged to try to correct the interference by one or more of the following measures:

- Reorient or relocate the receiving antenna.
- Increase the separation between the equipment and receiver.
- Connect the equipment into an outlet on a circuit different from that to which the receiver is connected.
- Consult the dealer or an experienced radio/TV technician for help.

### **Important**

Changes or modifications not expressly approved by Brother Industries, Ltd. could void the user's authority to operate the equipment.

### **Industry Canada Compliance Statement (For Canada Only)**

This Class B digital apparatus complies with Canadian ICES-003.

Cet appareil numérique de la classe B est conforme à la norme NMB-003 du Canada.

### **International ENERGY STAR® Compliance Statement**

As an ENERGY STAR® Partner, Brother Industries, Ltd. has determined that product meets the ENERGY STAR® guidelines for energy efficiency.



# Important Safety Instructions

---

- 1 Read all of these instructions.
- 2 Save them for later reference.
- 3 Follow all warnings and instructions marked on the product.
- 4 Unplug this product from the wall outlet before cleaning. Do not use liquid or aerosol cleaners. Use a damp cloth for cleaning.
- 5 Do not use this product near water.
- 6 Do not place this product on an unstable cart, stand, or table. The product may fall, causing serious damage to the product.
- 7 Slots and openings in the cabinet and the back or bottom are provided for ventilation; to ensure reliable operation of the product and to protect it from overheating, these openings must not be blocked or covered. The openings should never be blocked by placing the product on a bed, sofa, rug, or other similar surface. This product should never be placed near or over a radiator or heater. This product should never be placed in a built-in installation unless proper ventilation is provided.
- 8 This product should be operated from the type of power source indicated on the label. If you are not sure of the type of power available, consult your dealer or local power company.
- 9 This product is equipped with a 3-wire grounding type plug, a plug having a third (grounding) pin. This plug will fit into only a grounding-type power outlet. This is a safety feature. If you are unable to insert the plug into the outlet, contact your electrician to replace your obsolete outlet. Do not defeat the purpose of the grounding-type plug.
- 10 Do not allow anything to rest on the power cord. Do not place this product where people can walk on the cord.
- 11 If an extension cord is used with this product, make sure that the total ampere ratings on the products plugged into the extension cord do not exceed the extension cord ampere rating. Also, make sure that the total of all products plugged into the wall outlet does not exceed 15 amperes (USA only).
- 12 Do not place anything in front of the machine that will block received faxes. Do not place anything in the path of received faxes.
- 13 Wait until pages have exited the machine before picking them up.
- 14 Never push objects of any kind into this product through cabinet slots, since they may touch dangerous voltage points or short out parts resulting in the risk of fire or electric shock. Never spill liquid of any kind on the product.
- 15 Do not attempt to service this product yourself, as opening or removing covers may expose you to dangerous voltage points and/or other risks, and may void your warranty. Refer all servicing to Authorized Service Personnel. A list of Authorized Service Centers has been included for your convenience, or you may contact Customer Service for your nearest Brother Authorized Service Center. (See *Brother Numbers*, page i.)
- 16 This product does not have an ON/OFF switch. Therefore, it is very important that you have easy access to the main plug and the main socket to which the plug is connected, in case the main power to the MFC must be disconnected quickly.
- 17 Unplug this product from the wall outlet and refer servicing to Authorized Service Personnel under the following conditions:
  - A When the power cord is damaged or frayed.
  - B If liquid has been spilled into the product.
  - C If the product has been exposed to rain or water.
  - D If the product does not operate normally when the operating instructions are followed. Adjust only those controls that are covered by the operating instructions. Improper adjustment of other controls may result in damage and will often require extensive work by a qualified technician to restore the product to normal operation.
  - E If the product has been dropped or the cabinet has been damaged.
  - F If the product exhibits a distinct change in performance, indicating a need for service.
- 18 To protect your product against power surges, we recommend the use of a power protection device (Surge Protector).

## **Trademarks**

---

The brother logo is a registered trademark of Brother Industries, Ltd.

Brother is a registered trademark of Brother Industries, Ltd.

Windows, Microsoft, Excel and Word are registered trademarks of Microsoft in the U.S. and other countries.

Macintosh is a registered trademarks and iMac and iBook are trademarks of Apple Computer, Inc.

PaperPort and TextBridge are registered trademarks of ScanSoft, Inc.

JetPrint PHOTO is a registered trademark of International Paper.

Each company whose software title is mentioned in this manual has a Software License Agreement specific to its proprietary programs.

**All other brand and product names mentioned in this manual are registered trademarks of their respective companies.**

# 23 Troubleshooting and Routine Maintenance

## Troubleshooting

### IMPORTANT

For technical help you must call the country where you bought the MFC. Calls must be made *from within* that country.

### Error Messages

As with any sophisticated office product, errors may sometimes occur. If this happens, your MFC often identifies the problem and displays an error message. The table below explains the most common error messages.

You can correct most problems by yourself. If you need additional help, call the Brother fax-back system.

**In USA:** 1-800-521-2846

Or, visit us at: <http://solutions.brother.com>

### ERROR MESSAGES

ERROR MESSAGE	CAUSE	ACTION
CHECK CARTRIDGE	An ink cartridge is not installed properly.	Re-install the ink, seating it properly. See page 23-17.
CHECK ORIGINAL	Original was not inserted or fed properly, or document was longer than about 40" inches (90cm).	See page 23-3.
CHECK PAPER SIZE	Your paper is not the correct size.	Reload the correct size of paper, and then press <b>Black Fax Start</b> .
CHECK PAPER	MFC is out of paper.	Add paper, and then press <b>Black Fax Start</b> .
COMM. ERROR	Poor phone line quality caused a communication error.	Try the call again. If problem continues, call the telephone company to check your phone line.
CONNECTION FAIL	You tried to poll a fax machine that is not in Polled Waiting mode.	Verify the other party's polling setup.
HIGH TEMPERATURE	The print head detects high temperature.	Use the MFC in a cool room or lower the temperature.
COVER OPEN	Control panel cover or top cover is not closed completely.	Open and close the covers.
DISCONNECTED	The other party or other party's fax machine terminated the call.	Try to transmit or receive again.



<b>ERROR MESSAGES</b>		
<b>ERROR MESSAGE</b>	<b>CAUSE</b>	<b>ACTION</b>
<b>INK EMPTY</b>	<p>One or more of the ink cartridges are empty. The MFC will stop all print operations (such as printing copies, faxes and jobs from the PC). While memory is available, black and white faxes will be received into memory. If a sending machine has a color fax, the MFC's "handshake" will request that the fax be sent as black and white; if the sending machine has the feature to convert it, the color fax will be received into memory as a black and white fax.</p> <p>To preserve good quality, the MFC periodically cleans the print head. Also, you can press <b>Ink</b> to start the cleaning when needed. This cleaning process uses up ink and can cause the ink to run out.</p>	Replace the ink cartridges. See page 23-17.
<b>INK EMPTY &amp; FAX IN MEMORY</b>	MFC can not print fax messages because one or more of the ink cartridges are empty.	Replace the empty ink cartridges. See page 23-17.
<b>LOW TEMPERATURE</b>	The print head detects low temperature.	Use the MFC in a warm room or raise the temperature.
<b>MACHINE ERROR XX</b>	MFC has a mechanical problem.	<p>Call Brother Customer Service.</p> <p><b>In USA: 1-800-284-4329</b>  <b>In Canada: 1-877-BROTHER</b>  <b>In Montreal: (514) 685-6464</b></p>
<b>NEAR EMPTY</b>	<p>One or more of the ink cartridges are running out of ink. The MFC will stop receiving color faxes. The MFC's "handshake" will request that it be sent in black and white; if the sending machine has the feature to convert it, the color fax will be received into memory as a black and white fax.</p>	Order a new ink cartridge. See page ii.
<b>NO RESPONSE/ BUSY</b>	The number you dialed does not answer or is busy.	Verify the number and try again.
<b>NOT REGISTERED</b>	You tried to access a Speed Dial number that is not programmed.	Set up the Speed Dial number. See page 8-1.
<b>OUT OF MEMORY</b>	The data is too large for the MFC's memory.	See page 12-2.
<b>PAPER JAM</b>	The paper is jammed in the MFC.	See page 23-4.

## Original Jam

If the original is jammed, follow the steps below.

### Original is jammed inside front of control panel.

- 1 Remove any paper from the ADF that is not jammed.
- 2 Pull the jammed original out toward the front of the MFC.
- 3 Press **Stop/Exit**.



### Original is jammed inside back of control panel.

- 1 Remove any paper from the ADF that is not jammed.
- 2 Open the control panel cover.
- 3 Pull the jammed original out toward the back of the MFC.
- 4 Close the control panel cover.

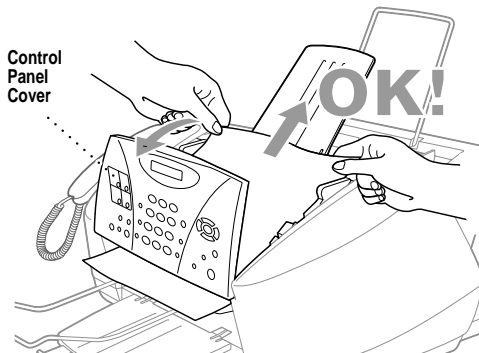

## Printer Jam or Paper Jam

Remove the jammed paper depending on where it is jammed in the MFC.

### Paper is jammed in the paper tray.

- 1 Remove any paper from the paper tray that is not jammed.
- 2 Pull up the jammed paper to remove it.

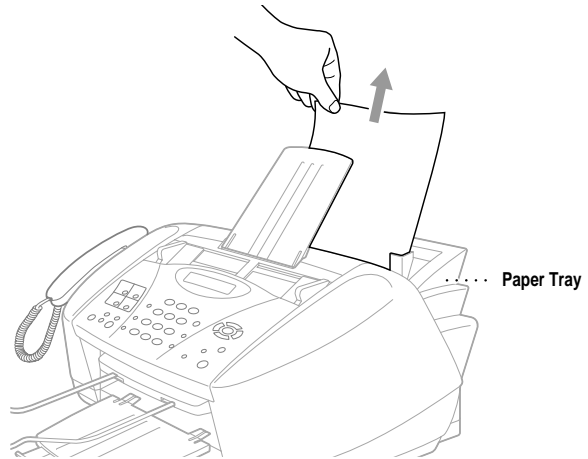

**Note** If it is difficult to pull the jammed paper, try to pull it while holding down the Paper Release Lever.

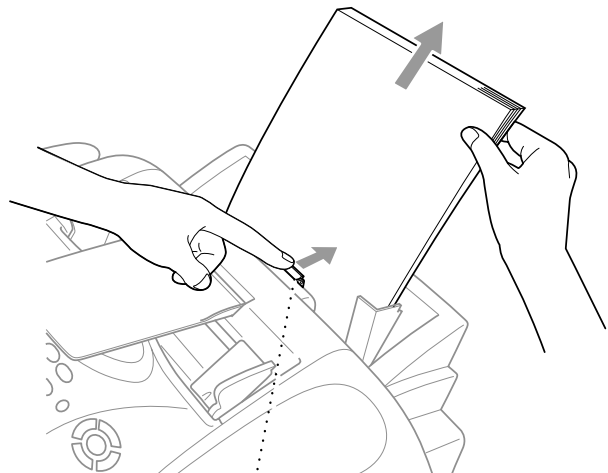

**Paper Release Lever**

**Note** To improve the reliability of paper feeding, turn on Secure Feed mode by pressing the **Shift** and **Scan to** keys simultaneously. The MFC will then feed paper more securely, but paper feeding will take a longer time. To turn off the Secure Feed mode, simultaneously press **Shift** and **Scan to** again.

**Paper is jammed inside the MFC.**

- 1 Open the control panel cover by lifting it toward you, and then lift the top cover toward the back.
- 2 Remove the jammed paper.

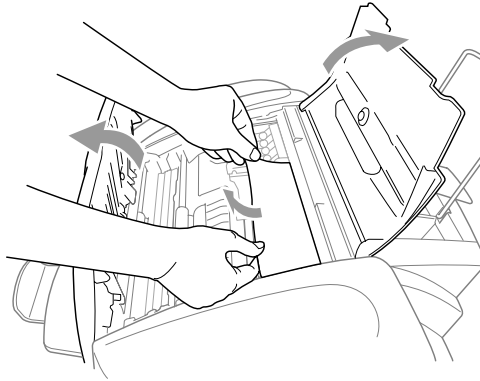

**Note** If the jammed paper is under the Print Head, unplug the MFC, and then you can move the Print Head to remove the paper.

- 3 Close the control panel cover and top cover.

**Paper is jammed inside the front of the MFC.**

- 1 Pull the paper toward you.

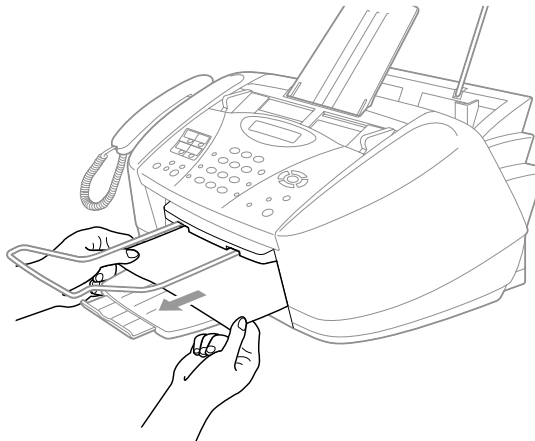

### Paper is jammed inside the back of the MFC.

If the paper rips, the pieces of paper may get stuck inside the back of the machine.

- 1 Remove any paper from the paper tray that is not jammed.
- 2 Open the Paper Jam Cover.
- 3 To loosen the paper, slide the Paper Width Guide to the widest position.
- 4 Use tweezers to pull out the ripped pieces of paper.
- 5 Close the Paper Jam Cover.

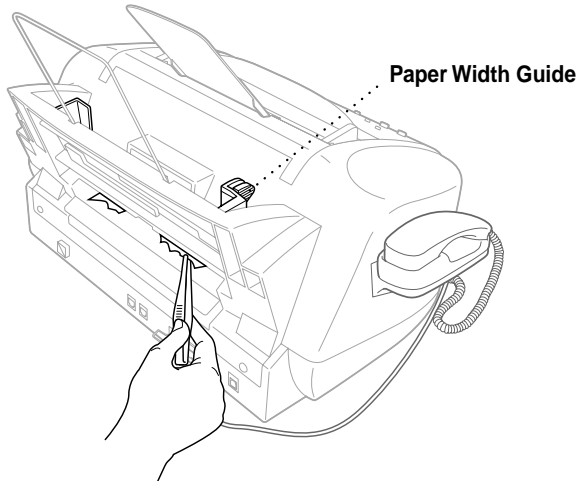

**Note** If **PAPER JAM** occurs frequently, install the Card Stock Support in the paper tray and reload the paper. Or, try reloading the paper upside down.

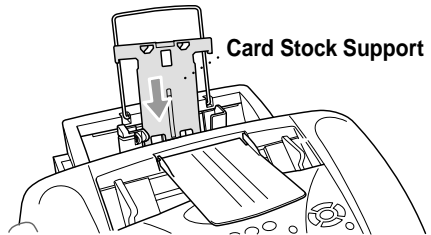

## If You Are Having Difficulty with Your MFC

If you think there is a problem with your MFC, *make a copy first*. If the copy looks good, the problem is probably not your MFC. Check the chart below and follow the troubleshooting tips.

If you have any other problems, visit us at: <http://solutions.brother.com>

DIFFICULTY	SUGGESTIONS
<b>Printing or Receiving Faxes</b>	
Condensed Print and Horizontal Streaks / Top and Bottom of Sentences Are Cut Off	If your copy looks good, you probably had a bad connection, with static or interference on the phone line. If the copy looks bad, call Brother Customer Service at 1-800-284-4329 (in USA), 1-877-BROTHER (in Canada) or (514) 685-6464 (in Montreal).
Poor Quality Print	Make sure the Printer driver matches the type of paper you are using (See page 14-2). If you are using plain paper, try using recommended special paper (See Chapter 3). Don't handle the paper until the ink is dry. Adjust the Vertical Alignment (See page 23-11).
Smudged stain on the top center of the printer page	Change Paper Thickness to Thick in the Paper tab of the Print dialog box, in the Printer driver setting.
Print Too Dark or Too Light	Make sure your ink cartridges are fresh. Cartridges are good up to two years; after that the ink may become clogged. Cartridge expiration dates are printed on the package. Try using recommended special paper (See Chapter 3). The recommended environment for your fax machine is between 68°F to 91°F.
Print Appears Dirty or Ink Seems to Run	Make sure you are using the recommended paper (See Chapter 3). Don't handle the paper until the ink is dry. The recommended environment for your MFC is between 68°F to 91°F.
White Lines in Text or Graphics	Clean the print head (See <i>Cleaning the Print Head</i> , page 23-10.).
Stains Appear on the Reverse Side or at the Bottom of the Page	Make sure the Printer Platen and Pick Up Roller are not dirty with ink mist. (See page 23-16).
Vertical Black Lines When Receiving	The sender's scanner may be dirty. Ask the sender to make a copy to see if the problem is with the sending machine. Try receiving from another fax machine. If the problem continues, call Brother Customer Service at 1-800-284-4329 (in USA), 1-877-BROTHER (in Canada) or (514) 685-6464 (in Montreal).
Received color fax prints only in B & W.	Replace the color ink cartridges that are empty or nearly empty, and then ask the other party to send the color fax again. (See <i>Replacing the Ink Cartridges</i> , page 23-17.)
Left and right margins are cut off.	Turn on Auto Reduction. (See <i>Printing a Reduced Incoming Fax (Auto Reduction)</i> , Page 6-4.)
Horizontal lines appear in Text or Graphics.	Clean the print head (See <i>Cleaning the Print Head</i> , page 23-10.). If you clean the print heads five times and the print has not improved, call Brother Customer Service at 1-800-284-4329 (in USA), 1-877-BROTHER (in Canada) or (514) 685-6464 (in Montreal).
<b>Phone Line or Connections</b>	
Dialing does not work.	Check for a dial tone. Change TONE/PULSE setting (See <i>Setting Tone/Pulse Dialing Mode</i> , page 5-7). Check all line cord connections, and make sure the curled handset cord is not in the EXT jack. Check power cord connection. Send a manual fax by pressing <b>Hook/Hold</b> —OR—by lifting the handset, and dialing the number. Wait to hear the MFC receiving tones before pressing <b>Black Fax Start</b> .

DIFFICULTY	SUGGESTIONS
MFC Does Not Answer When Called	Make sure the MFC is in the correct receiving mode for your setup (either <b>FAX ONLY</b> , <b>FAX/TEL</b> or <b>TAD: ANSWER MACH</b> ). Check for dial tone. If possible, call your MFC to hear it answer. If there is still no answer, check the telephone line cord connection. If there is no ringing when you call your MFC, call your telephone company to check the line.
There is no dial tone on the handset.	Press <b>Hook/Hold—OR—Lift</b> the handset. If you hear no dial tone, check telephone line cord connections at the MFC and wall jack. Check that the handset curled cord is connected to the MFC's handset jack. Test the jack with another single line telephone. If no dial tone on the wall outlet, call your telephone company.
<b>Sending Faxes</b>	
Poor Transmission Quality	Try changing your resolution to <b>FINE</b> or <b>S.FINE</b> . Make a copy to verify your MFC's scanner operation.
Transmission Verification Report says "Result:NG"	There is probably temporary noise or static on the line. Try sending the fax again. If you send a PC FAX message and get "Result:NG" on the Transmission Verification Report, your MFC may be out of memory. To gain extra memory, you can turn off Fax Storage (See page 10-2), print fax message in memory (See page 6-6) or cancel a delayed fax or polling job (See page 6-7). If the problem continues, call the telephone company to check your phone line.
Vertical Black Lines When Sending	If the copy you made shows the same problem, your scanner is dirty (See <i>Cleaning the Scanner</i> , page 23-16.).
<b>Handling Incoming Calls</b>	
MFC "Hears" Voice as CNG Tone	If your MFC is set to Easy Receive ON, it is more sensitive to sounds. Your MFC may mistakenly interpret certain voices or music on the line as a calling fax machine and respond with fax receiving tones. Deactivate the fax by pressing <b>Stop/Exit</b> . Try avoiding this problem by turning Easy Receive to OFF. (See <i>Easy Receive</i> , page 6-3.)
Transferring a Fax Call to the MFC	If you answered at the MFC, press <b>Black Fax Start</b> and hang up immediately. If you answered at an extension phone, press your Fax Receive Code (default setting is *51). When your MFC answers, hang up.
Custom Features on a Single Line	If you have Call Waiting, Call Waiting/Caller ID, Ring Master, Voice Mail, an alarm system or any other custom feature on a single phone line with your MFC, it may create a problem sending or receiving fax data. For example: If you are sending or receiving a fax message while a custom feature signal comes through on the line, the signal can temporarily interrupt or disrupt the fax data. Brother's ECM feature should help overcome this problem. This condition is related to the telephone system industry and is common to all devices that send and receive information on a single, shared line with custom features. If avoiding a slight interruption is crucial to your business, a separate line with no custom features is recommended.
<b>Printer Difficulties</b>	
Horizontal lines appear in Text or Graphics.	Clean the print head (See <i>Cleaning the Print Head</i> , page 23-10.). If you clean the print heads five times and the print has not improved, call Brother Customer Service at 1-800-284-4329 ( <b>in USA</b> ), 1-877-BROTHER ( <b>in Canada</b> ) or (514) 685-6464 ( <b>in Montreal</b> ).
<b>Scanning Difficulties</b>	
TWIN Errors appear while scanning	Make sure the Brother TWIN driver is selected as the primary source. In PaperPort®, click File Select Source, highlight the Brother TWIN driver and click Select.

DIFFICULTY	SUGGESTIONS
<b>Software Difficulties</b>	
Cannot perform '2 in 1' printing.	Check that the paper size setting in the application and in the printer driver are the same.
Cannot print when using Paint Brush.	Try setting the Display setting to '256 colors.'
Cannot print when using Adobe Illustrator.	Try to reduce the printing resolution.
Thick line and thin line appear alternately. (banding)	Turn OFF 'Bi-Directional Printing' from the 'Quality/Color' tab in the printer driver.
There are some dense lines.	Turn ON 'Reverse Order' from the 'Paper' tab in the printer driver.
When using ATM fonts, some characters are missing or some characters are printed in the same place.	If you are using Windows® 98, select 'Printer Settings' from the 'Start' menu. Open 'Brother XXXX' properties. Click 'Spool Setting' on the 'Details' tab. Select 'RAW' from 'Spool Data Format'.
Printing is slow.	In the Quality/Color tab of the Print dialog box, select Auto in the Document section.
True2Life is not working correctly.	If the image data is not full color (such as 256 color) in your application, True2Life does not function. Please use at least 24 bit color data with the True2Life feature.
"MFC is Busy" or "MFC Connect Failure" Error Message appears.	Make sure the MFC is not displaying an error message on the LCD.
"MFC Connect Failure"	If the MFC is not connected to your PC and you have loaded the Brother software, the PC will show "MFC Connect Failure" each time you restart Windows®. You can ignore this message or you can turn it off by deselect the <b>AutoLoad PopUp</b> check box in the Brother Control Center chapter. (See <i>How to Turn Off AutoLoad</i> , page 15-2.)



# How to Improve Print Quality

## Cleaning the Print Head

Clean the print head and ink cartridges if you get a horizontal line in the text or graphics on your printed pages. Using the **Ink** key, you can clean one color at a time (BLACK, CYAN, YELLOW, or MAGENTA) or all four colors at once.

### ! Caution

**Do NOT clean the print head by touching it with your hand or a cloth.**

- 1 Press **Ink**.
- 2 Press **1** to select **1.CLEANING**.
- 3 Press  to select the color you want to clean, and then press **Menu/Set**.

The MFC will clean the print head. When cleaning is finished, the MFC will go back online automatically.



If you clean the print head at least five times and the print has not improved, call Brother Customer Service for help at 1-800-284-4329 (**in USA**), 1-877-BROTHER (**in Canada**), or (514) 685-6464 (**in Montreal**).

## Print Quality Check

If the print quality is not good, you can print a Print Quality Check Sheet to help you find the settings you may need to change.

- 1 Press **Menu/Set, 4**.
- 2 Press **Black Fax Start**.  
The MFC begins printing the Print Quality Check Sheet.  
The LCD shows:

4. TEST PRINT

IS STEP "A" OK?  
1. YES 2. NO

- 3 Check the sheet to see if the quality and alignment are OK by following STEPs A and B.

### STEP A: Color Block Quality Check

The LCD shows:

IS STEP "A" OK?  
1. YES 2. NO

- 4 Check the quality of the four color blocks on the sheet. (BLACK/CYAN/YELLOW/MAGENTA).

5 If the quality is OK for all colors, press **1 (YES)** to go to **STEP B**

—OR—

If white horizontal lines appear in some color blocks below, press **2 (NO)**.

OK



Poor



The LCD will ask you if the print quality is OK for each color.

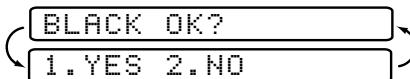

6 Press **2 (NO)** for any color with a problem.

The LCD shows:

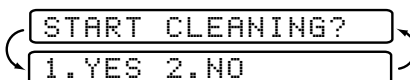

7 Press **1 (YES)**. The MFC will start cleaning the color.

8 After cleaning is finished, press **Black Fax Start**. The MFC will start printing the Print Quality Check Sheet again and then return to **STEP A**.

9 If **STEP A** is OK, press **1** to go to **STEP B**.

### STEP B: Alignment Check

The LCD shows:

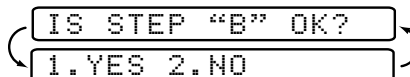

10 Check the 600 DPI and 1200 DPI test prints to see if number 5 most closely matches number 0. If the number 5 sample of both the 600 DPI and 1200 DPI are the best matches, press **1 (YES)** to finish **STEP B**

—OR—

If another test print number is a better match for either 600 DPI or 1200 DPI, press **2 (NO)** to select it.

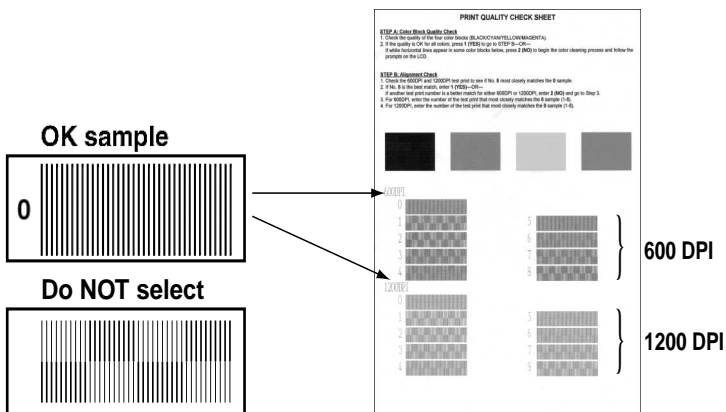

**11** For 600 DPI, press the number of the test print that most closely matches the number 0 sample (1-8).

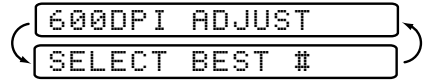

**12** For 1200 DPI, press the number of the test print that most closely matches the number 0 sample (1-8).



**13** Repeat Steps 1 and 2 (in *Print Quality Check*) to print another sample Print Quality Check Sheet, and then check it.

**14** Press **Stop/Exit**.



When an ink head nozzle is clogged the printed sample looks like this.



After the ink head nozzle is cleaned, the horizontal lines are gone.

If you still see missing ink in this Print Quality Check Sheet, repeat the cleaning and test print procedures at least five times. If ink is still missing after the fifth cleaning and test print, replace the ink cartridge for the clogged color. (Perhaps the ink cartridge was in your MFC over six months or the expiration date written on the cartridge package has passed. Or, the ink may not have been stored properly before use.)

After replacing the ink cartridge, check it by printing another Print Quality Check Sheet. If the problem still exists, repeat the cleaning and test print procedures at least five times for the new ink cartridge. If ink is still missing, call Customer Service at 1-800-284-4329 (**in USA**), 1-877-BROTHER (**in Canada**) or (514) 685-6464 (**in Montreal**).



### **Caution**

Do NOT touch the print head. Touching the print head may cause permanent damage and may void the print head's warranty.

# Packing and Shipping the MFC

---

Whenever you transport the MFC, use the packing materials that came with your MFC. If you do not pack the MFC correctly, you could void your warranty.

- 1 First, remove all the ink cartridges and attach the white shipping cover. (See *Replacing the Ink Cartridges*, page 23-17.) After attaching the white shipping cover, press the all ink cartridge covers down.

To attach the white shipping cover

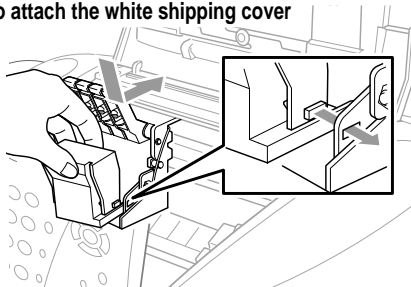

## ! Caution

Damage to your print head resulting from packing without the shipping cover may void your warranty.

- 2 Attach the protective yellow bar, and then close the top cover and control panel cover until they click into place.

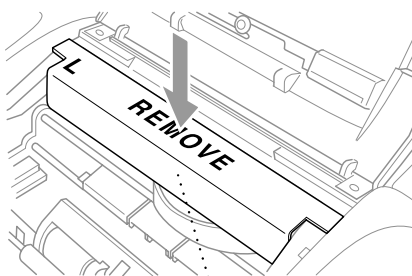

Protective Yellow Bar

- 3 Unplug the MFC from the telephone wall jack and remove the telephone line cord from machine.

## ! Caution

Do not unplug the MFC after a print job until you hear the final click.

- 4 Unplug the MFC from the AC outlet.
- 5 Unplug the USB cable from the MFC, if it is connected.
- 6 Remove the paper support, output paper support, ADF document support, ADF document output support, handset and handset curled cord.



If you are packing the machine for the Brother Exchange Service, keep these items and return only the machine.

- 7 Wrap the MFC in the bag and place it in the original carton with the original packing material.

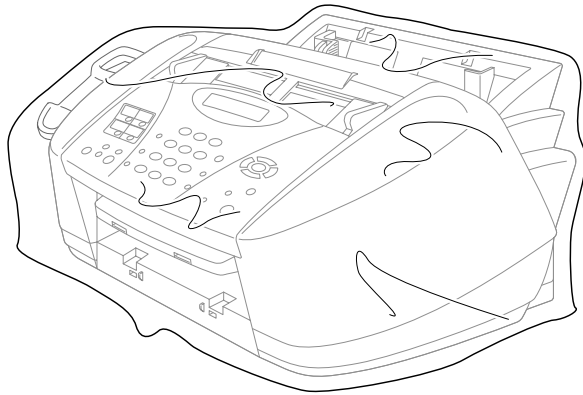

- 8 Pack the printed materials in the original carton as shown below. Do not pack the used ink cartridges in the carton.

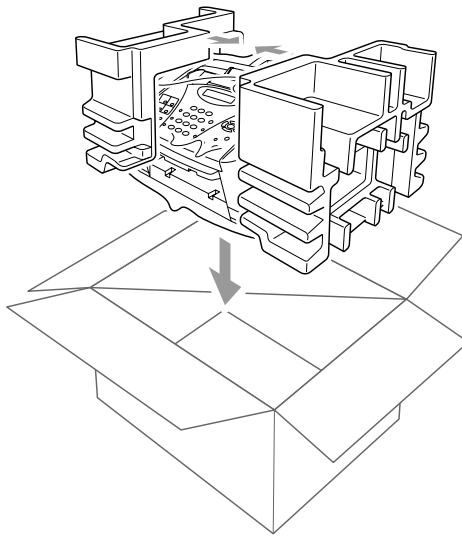

**Note** If you are returning your machine to Brother as part of the Exchange Service, pack *only* the MFC. Keep all separate parts and printed materials to use with your “Exchange” machine.

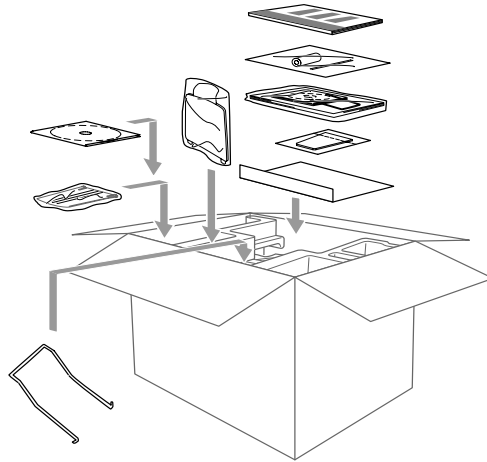
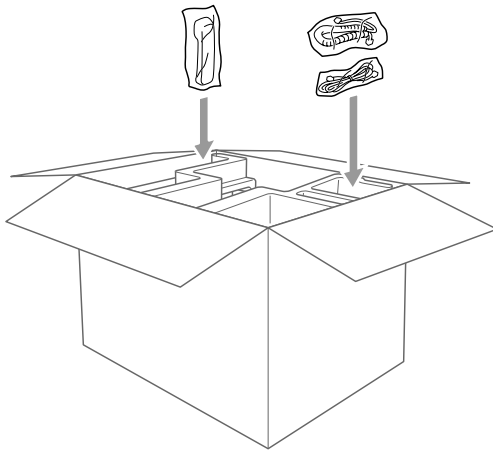

**9** Close the carton.

# Routine Maintenance

---

## Cleaning the Scanner

Unplug the MFC, and then open the control panel cover. Clean the flat white pressure bar and the glass strip under the bar with isopropyl alcohol on a lint-free cloth.

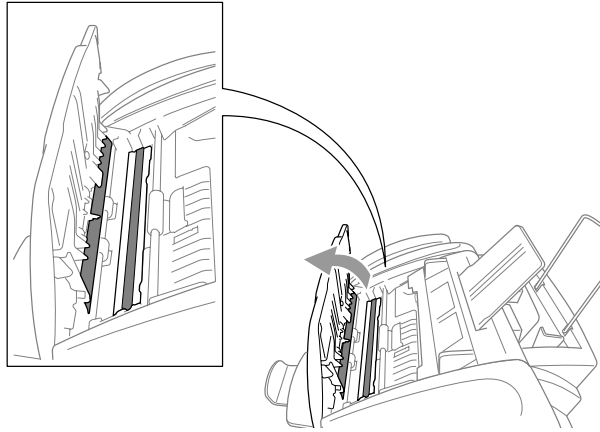

## Cleaning the MFC Printer Platen



### WARNING

- Be sure to unplug the MFC from the AC power outlet before cleaning the printer platen.
- Be careful not to touch the paper feed star wheels, flat cable and encode film.

When you want to clean your MFC printer platen, wipe it with a lint free cloth that is *dry*.

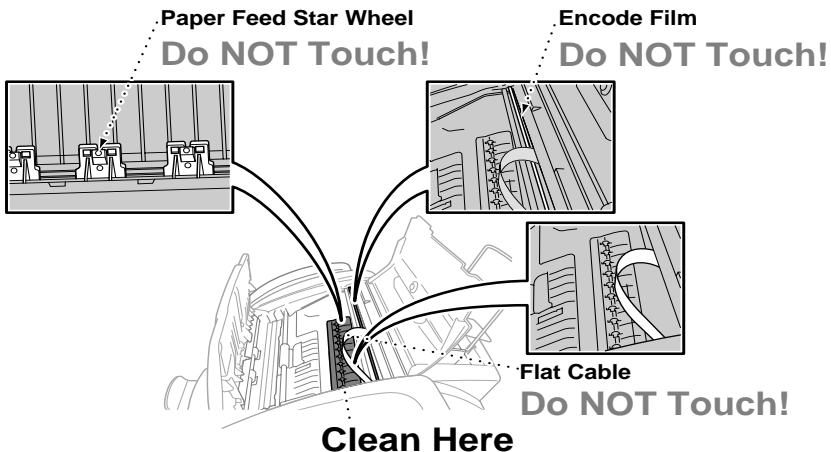

## Replacing the Ink Cartridges

Your MFC is equipped with an ink dot counter that automatically monitors the ink level in each color cartridge. When the counter detects an ink cartridge is running out of ink, the MFC will notify you with a message on the LCD.

The LCD shows you which color cartridges are low or empty. Be sure to follow the LCD prompts so you replace the color cartridges in the appropriate order.

**When the ink cartridges are running low, you must use the Ink key to begin the cartridge replacement (Steps 1 to 3). If the ink is empty, skip to Step 4.**

- 1 Press **Ink**.
- 2 Press **2** to choose **2. REPLACE INK**.  
If one or more ink cartridges are empty, for example Black, the LCD shows **INK EMPTY BLACK** and **PLS OPEN COVER**
- 3 Open the control panel cover, and then lift the top cover.
- 4 Push the appropriate colored ink cartridge covers and remove the ink cartridge.

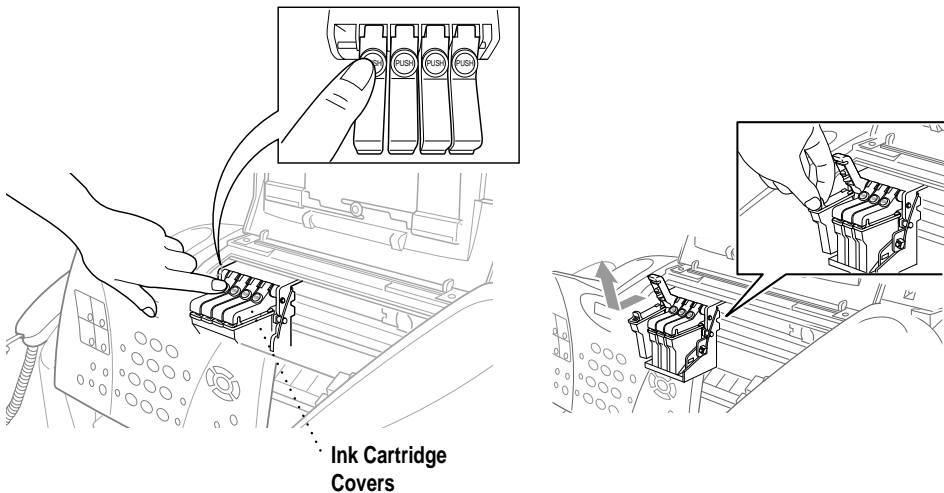

- 5 Open the new ink cartridge bag for the color shown on the LCD, and then take out the ink cartridge.



- 6 Hold the new ink cartridge as shown in the illustration, and then peel the sealing tape from the side of the ink cartridge. Carefully peel the tape in the direction away from you.

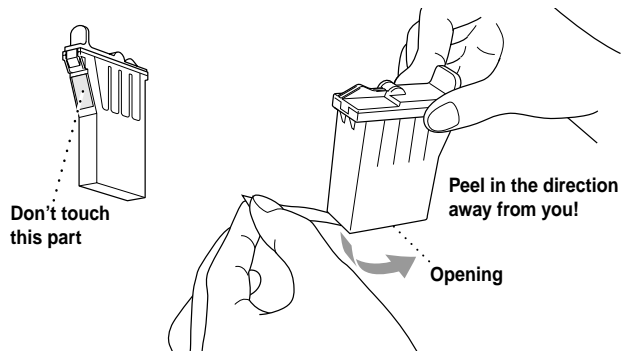

**Note** To prevent spilling ink and staining your hands and clothing, remove the sealing tape gently.

- 7 Each color has its own correct position. Insert each new ink cartridge into the carriage.
- 8 After installing the ink cartridges, close the top cover and control panel cover. Your MFC prepares for a “head cleaning” and goes online. The LCD prompts you to verify a new ink cartridge was inserted for each color you removed. Example: **DID YOU CHANGE BLCK? 1. YES 2. NO.** If the ink cartridge you installed is not a brand new one, please make sure to select 2.
- 9 For each new cartridge, press **1** on the dial pad to reset the ink dot counter for that color automatically. (The ink dot counter enables the MFC to notify you when a color is running low.) The MFC will enter a cleaning cycle for approximately 3 minutes for each replaced cartridge. The LCD alternately shows **CLEANING** and **PLEASE WAIT**.

When the MFC completes the cleaning cycle, the LCD returns to Standby mode (date and time).



### **WARNING**

If ink gets in your eyes, irrigate them with water immediately and consult a doctor if you are concerned.

## **Caution**

- DO NOT remove ink cartridges if you do not need to replace them. If you do so, it may reduce the ink quantity and the printer will not know the quantity of ink left in the cartridge.
- DO NOT shake the ink cartridges, because the ink may spill when you take off the sealing tape.
- If ink stains your body or clothing, wash with soap or detergent immediately.
- If you install an ink cartridge in the wrong color position, you must clean the print head several times before you start printing (after correcting the cartridge installation) because the colors were mixed.
- Once you open an ink cartridge, install it in the MFC and use it up within six months of installation. Use unopened ink cartridges by the expiration date written on the cartridge package.
- Brother strongly recommends that you do not refill the ink cartridges provided with your machine. We also strongly recommend that you continue to use only Genuine Brother Brand replacement ink cartridges. Using or attempting to use potentially incompatible inks and/or cartridges in your machine may cause damage to the machine itself and/or it may result in unsatisfactory print quality. Our warranty coverage does not apply to any problem that was caused by the use of unauthorized third party ink and/or cartridges. To protect your investment and guarantee your print quality please continue to replace consumed ink cartridges with only Genuine Brother Branded Supplies.



If the **INK EMPTY** message is on the display after you have installed ink cartridges, check that the ink cartridges are installed correctly.

If you still cannot solve a problem with your MFC, call Brother Customer Service (See *Brother Numbers*, page i).

# S Specifications

## Product Description

The MFC-3200C is a **5 in 1** Multi-Function Center: Color Printer, Color Copier (single copies), Color Scanner, Plain Paper Fax, and PC FAX (via your PC).

## Fax

<b>Compatibility</b>	ITU-T Group 3
<b>Coding System</b>	MH/MR/MMR/JPEG
<b>Modem Speed</b>	33600-2400 bps Automatic Fallback
<b>Cut Sheet Size</b>	Min. 3.5" (W) × 5.0" (L) Max. 8.5" (W) × 14.0" (L)
<b>Scanning Width</b>	8.2 inches (208 mm)
<b>Printing Width</b>	8 inches (203.2 mm)
<b>Automatic Document Feeder (ADF)</b>	up to 20 sheets (20 lbs.)
<b>Paper Tray</b>	100 Sheets (20 lbs.)
<b>Printer Type</b>	Ink Jet
<b>Gray Scale</b>	256 levels (Error Diffusion)
<b>Display</b>	LCD, 16 characters
<b>Polling Types</b>	Standard, Sequential
<b>Contrast Control</b>	Automatic/Super Light/Super Dark (manual setting)
<b>Resolution</b>	<ul style="list-style-type: none"><li>• Horizontal 203 dot/inch (8 dot/mm) (Black/Color)</li><li>• Vertical Standard — 98 line/inch (Black) (3.85 line/mm)</li><li>— 196 line/inch (Color) (7.7 line/mm)</li><li>Fine — 196 line/inch (Black/Color) (7.7 line/mm)</li><li>Photo — 196 line/inch (Black) (7.7 line/mm)</li><li>Superfine — 392 line/inch (Black) (15.4 line/mm)</li></ul>
<b>Memory Capacity</b>	8 MB (up to 480 pages)*

\* “Pages” refers to the “Brother Standard Chart No.1” (a typical business letter, Standard resolution, MMR code). Specifications and printed materials are subject to change without prior notice.

<b>One Touch Dial</b>	8 stations
<b>Speed Dial</b>	100 stations
<b>Automatic Redial</b>	3 times at 5 minute intervals
<b>Auto Answer</b>	0, 1, 2, 3 or 4 rings
<b>Communication Source</b>	Public switched telephone network
<b>Operating Environment</b>	50–95° F (10–35° C)
<b>Best Print Quality</b>	68–91° F (20–33° C)
<b>Power Source</b>	120V AC 50/60Hz (USA, Canadian Version Only)
<b>Power Consumption</b>	Standby: under 7 watts Peak: under 35 watts
<b>Dimensions (WxDxH)*</b>	19.1 × 13.5 × 8.5 (inches) 486 × 342 × 217 (mm)
<b>Weight*</b>	14.3 lb./6.5 kg

\* The ADF Document Support, Paper Support, ADF Document Output Support and Output Paper Support are not included.

## Printer

---

### Printing

<b>Print Method</b>	Piezo with 75 × 4 nozzles
<b>Resolution</b>	2400 × 1200 dots per inch (DPI) 1200 × 1200 dots per inch (DPI) 600 × 600 dots per inch (DPI) 600 × 300 dots per inch (DPI) 600 × 150 dots per inch (DPI)
<b>Print Speed</b>	up to 10 pages/minute (Mono) up to 8 pages/minute (Color)
<b>Print Width</b>	8 inches (203.2 mm)
<b>Disk-Based Fonts</b>	35

### Controller

<b>USB Interface</b>	A Standard Universal Serial Bus cable that is no longer than 6 feet (1.8 m)
----------------------	---



To meet FCC emission requirements for the MFC, you must attach the included filter core and cable tie to a USB cable (USB cable not included).

# Computer Requirements

Minimum System Requirements					
Computer Platform & Operating System Version		Processor Minimum Speed	Minimum RAM	Recommended RAM	Available Hard Disk Space
Windows® Operating Systems	98, 98SE	Pentium 75MHz	24MB	32MB	80MB
	Me	Pentium 150MHz	32MB	64MB	
	2000 Professional	Pentium 133MHz	64MB	128MB	
	XP	Pentium 233MHz			240MB
Apple iMac™/iBook™/G3/G4 Operating Systems	OS 8.5 (Printing and PC FAX Send)	All base models meet minimum requirements	32MB	64MB	50MB
	OS 8.6 – 9.2 (Printing, Scanning and PC FAX Send)				
	Mac OS X v.10.1 (Printing Only)		128MB	160MB	

**NOTE:**  
All registered trademarks referenced herein are the property of their respective companies.

## Print Media

### Paper Input

Automatic loading from the Paper Tray

- Paper type:  
Plain paper, inkjet paper (coated paper), glossy paper, transparencies and envelopes
- Paper size:  
A4, Letter, Legal, A5, Executive, envelopes (COM-10, DL, C5, Monarch), Postcard, Index card.
  - Width 3.5–8.5" (89–216 mm)
  - Length 5–14" (127–356 mm)
  - Weight 17–32 lb. (64–120 g/m<sup>2</sup>)
  - Thickness 0.003-0.006" (0.08-0.15 mm)  
envelopes: up to 0.02" (0.52 mm)  
postcard: up to 0.009" (0.23 mm)  
glossy paper: up to 0.007" (0.18 mm)
- Maximum paper tray capacity: Approx. 100 sheets of 20 lb. (75 g/m<sup>2</sup>) plain paper.

### Paper Output

Approximately 50 sheets of plain paper (Face up print delivery to the output paper support)

We recommend that you remove each sheet immediately from the output paper support to prevent a paper jam or curled pages.

## Consumable Items

### Ink

Black and 3 individual color ink cartridges separate from the print head.

### Service Life of Ink Cartridge

Approximately 950 page/Black cartridge at 5% coverage with  $600 \times 150$  dpi resolution (Draft).  
Approximately 450 page/Color cartridge at 5% coverage with  $600 \times 150$  dpi resolution (Draft).



These numbers are based on consecutive printing; the numbers will vary based on print frequency and number of pages.  
The MFC periodically cleans the print head to maintain print quality. This process consumes a small amount of ink.

# Glossary

---

- ADF (Automatic Document Feeder)** Refers to the number of pages that can be placed in the document feeder and fed one at a time automatically.
- Auto Dial List** A listing of names and numbers stored in Speed Dial memory, in numerical order.
- Automatic E-Mail Printing** Software application that automatically prints incoming e-mail messages on the MFC (on the CD-ROM).
- automatic fax transmission** Sending a fax without picking up the handset of an external phone.
- Automatic Redial** A feature that enables your MFC to redial the last fax number if the original fax did not go through because the line was busy or there was no answer.
- Backup Print** Your MFC prints a copy of every fax that is received and stored in memory. This is a safety feature so you will not lose messages during a power failure.
- Batch Transmission** As a cost savings feature, all delayed faxes to the same fax number will be sent as one transmission.
- beeper** The sound the keys make when they are pressed, an error occurs or a document has been received or transmitted.
- beeper volume** Volume setting for the beep when you press a key or make an error.
- Brightness** Changing the Brightness makes the whole image lighter or darker.
- Broadcasting** (Not Available for Color Faxes) The ability to send the same fax message to more than one location.
- Caller ID** A service purchased from the telephone company that lets you see the number (or name) of the party calling you.
- cancel job** You can cancel a programmed job, like Delayed Fax or Polling.
- CNG tones** The special tones (beeps) sent by fax machines during automatic transmission to tell the receiving machine that they are a from fax machine.
- communication error (or Comm. Error)** An error during fax sending or receiving, usually caused by line noise or static.
- Coding Method** Method of coding the information contained in a document. All fax machines must use a minimum standard of Modified Huffman (MH). Your fax machine is capable of greater compression methods, Modified Read (MR) and Modified Modified Read (MMR), if the receiving machine has the same capability.
- Compatibility Group** The ability of one fax unit to communicate with another. Compatibility is assured between ITU-T Groups.
- Contrast** Setting to compensate for dark or light documents, by lightening dark originals or darkening light originals.
- Cover Page** Prints a page at the other party's fax machine that contains the sender and recipient's name and fax number, number of pages and comment. You can generate an electronic cover page at the other end with pre-programmed information from memory or you can print a sample cover page to fax with your original.

**Cover Page Message** The comment that is on the Cover Page. This is a programmable feature.

**Delayed Fax** (Not Available for Color Faxes) Sends your faxes at a later time that day.

**Distinctive Ring** A service purchased from the Telephone Company that provides another phone number on an existing phone line. The Brother MFC uses the new number to simulate a dedicated fax line.

**Dual Access** (Not Available for Color Faxes) Your MFC can scan outgoing faxes or scheduled jobs into memory at the same time it is sending a fax or receiving or printing an incoming fax.

**Easy Receive** Enables your MFC to respond to CNG tones if you interrupt a fax call by answering it.

**ECM (Error Correction Mode)** Detects errors during fax transmission and resends the page(s) of the document that had an error.

**E-Mail Printing** Software application that automatically retrieves your e-mail messages from your POP3 server and prints them on your MFC.

**Electronic Cover Page** A preprogrammed cover page that is transmitted from the MFC's memory, eliminating the need for creating cover pages manually.

**extension phone** A telephone on the fax number that is plugged into a separate wall jack.

**external phone** A TAD (telephone answering device) or telephone that is plugged into the EXT jack of your MFC.

**Fax Activity Report** Lists information about the last 200 incoming and outgoing faxes. TX means Transmit. RX means Receive.

**Fax Forwarding** (Not Available for Color Faxes) Sends a fax received in memory to another preprogrammed fax number.

**Fax Storage** (Not Available for Color Faxes) You can print stored faxes later, or retrieve them from another location using Fax Forwarding, Paging, or Remote Retrieval operations.

**fax tones** The signals sent by sending and receiving fax machines while communicating information.

**Fine resolution** 196 × 203 dpi. It is used for small print and graphs.

**gray scale** The shades of gray available for copying and faxing photographs.

**Group number** A combination of One Touch and Speed Dial numbers that are stored on a One Touch key or Speed Dial location for Broadcasting.

**Ink button** Cleans the print head and/or resets the ink dot counter after replacing an ink cartridge.

**Interval** The preprogrammed time period between automatically printed Activity Reports. You can print Activity Reports on demand without interrupting this cycle.

**LCD (liquid crystal display)** The display screen on the MFC that shows interactive messages during On-Screen Programming. The LCD shows the date and time while the machine is idle.

**manual fax** When you lift the handset of your external telephone so you can hear the receiving fax machine answer before you press Start to begin transmission.

**Menu Mode** The programming mode for changing the settings for your MFC.

**Multi-Function Link<sup>®</sup> Pro Suite Software application** Turns your MFC into a printer and a scanner and enables PC faxing using the MFC.



- Next Fax Reservation** Dual Access accepts the next original in the ADF for real-time transmission while the Memory is full.
- OCR (optical character recognition)** The bundled ScanSoft™ TextBridge® software application converts an image of text to text you can edit.
- One Touch** Keys on the MFC control panel where you can store numbers for easy dialing.
- Out of Paper Reception** Receives faxes into the MFC's memory when the machine is out of paper.
- Overseas mode** Makes temporary changes to the fax tones to accommodate noise and static on overseas phone lines.
- Paging** Feature enables your MFC to call your pager when a fax is received into its memory.
- Pause** Allows you to place one or more 3.5 second delays in the dialing sequence of stored One Touch and Speed Dial numbers.
- Photo resolution** (Not Available for Color Faxes) Varying shades of gray provide the best representation of photographs.
- Polling** The process of a fax machine calling another fax machine to retrieve waiting fax messages.
- printer alarm** Audible alarm when the printer is not able to print.
- Pulse (For Canada only)** A form of rotary dialing on a telephone line.
- Real Time Transmission** When memory is full, you can send documents in real time.
- Reduction** reduces the size of incoming faxes.
- remaining jobs** You can check which jobs are waiting in memory and cancel jobs individually.
- Remote Activation** allows you to transfer a fax call, answered at an extension phone, to the MFC.
- Remote Retrieval Access Code** The four-digit code (159\*) that allows you to call and access your MFC from a remote location.
- Resolution** The number of vertical and horizontal lines per inch. See: Standard, Fine, Super Fine and Photo.
- Ring Delay** The number of rings before the MFC answers in FAX ONLY and FAX/TEL modes.
- Ring Volume** Volume setting for the MFC's ring.
- scanning** The process of sending an electronic image of an original paper document into your computer.
- ScanSoft™ PaperPort® for Brother** A document management application that enables you to view incoming faxes and scanned documents.
- Speaker Volume** You can set the volume when your MFC is on **Hook/Hold**.
- Speed Dial** A preprogrammed number for easy dialing. You must press the **Search/Speed Dial** button and then #, two digit code to start the dialing process.
- Standard resolution** 98 × 203 dpi. Use it for regular size text and quickest transmission.
- Station ID** The stored information that appears on the top of faxed pages. It includes the sender's name and fax number.

**Super Fine resolution** (Not Available for Color Faxes) 392 × 203 dpi. It is best for very small print and line art.

**TAD (telephone answering device)** You can connect an *external* TAD to the EXT. jack of the MFC for TAD: ANSWER MACH. mode.

**temporary settings** You can select certain options for the next fax transmission or copy you make without changing the default settings.

**Tone** The telephone line mode that is used for dialing with Touch Tone telephones.

**transmission** The process of sending documents over the phone lines from your MFC to the receiving fax machine.

**Transmission Verification Report** A listing of each transmission that shows its date, time, and number of pages. OK means delivered; NG means failed.

**User Settings List** A printed report that shows the current settings of your MFC.

# Index

- A**
- access codes, storing and dialing .....8-6
  - accessories and supplies .....ii
  - ADF (Automatic Document Feeder) ....7-1
  - alternating displays .....4-1
  - assembly .....2-3
    - ADF document output support .....2-7
    - ADF document support .....2-6
    - grounded 3-prong plug .....2-4
    - loading paper .....2-8
    - output paper support .....2-6
    - paper support .....2-5
  - automatic
    - dialing ..... 8-4, 8-5
    - fax receive .....6-1
    - fax redial .....7-4
    - transmission .....7-3
- B**
- Backup Print .....10-2
  - Brightness .....1-4
  - Broadcasting .....8-6
    - setting up Groups for .....8-3
  - Brother
    - accessories and supplies .....ii
    - Brother numbers .....i
    - Customer Service .....i
    - fax back system .....ii
    - Frequently Asked Questions (FAQs) ....i
    - test sheet, sending .....1-2
  - Brother Control Center
    - using and configuring .... 15-2 to 15-14
- C**
- CALL PICKUP .....9-3
  - Caller ID ..... 9-3, 9-4
  - canceling
    - Fax Forwarding .....10-4
    - fax jobs in memory .....6-7
    - jobs awaiting redial .....7-6
    - Paging .....10-4
    - scheduled jobs .....6-7
  - cleaning
    - cycle .....2-12
    - print head .....23-10
    - printer platen .....23-16
    - scanner .....23-16
  - CNG tones .....1-5
  - connecting .....2-1
  - control panel, overview .....1-3
  - copy
    - brightness .....12-4
    - color adjustment .....12-8
    - contrast .....12-8
    - default settings .....12-7
    - enlarging .....12-5
    - multiple .....12-1
    - quality .....12-8
    - reducing .....12-5
    - single .....12-1
    - temporary settings .....12-2
  - cordless .....2-13
  - cover page .....5-2, 7-7, 7-8, 7-9
    - custom comments .....7-7
    - for all faxes .....7-8
    - for next fax only .....7-8
    - printed form .....7-9
  - credit card numbers .....8-6
  - custom telephone features ..... 2-18, 23-8
  - Customer Service .....i
- D**
- date and time .....5-2
  - Delayed Batch Transmission .....7-10
  - Delayed Fax .....7-10
  - dialing
    - automatic fax redial .....7-4
    - Groups .....8-6
    - One Touch numbers .....8-5
    - Search .....8-4
    - Speed Dial numbers .....8-5

document  
 jam .....23-3  
 size and resolution .....7-1  
 drivers  
 printer .....14-1  
 TWAIN Compliant .....17-1  
 Dual Access .....7-4

## E

Easy Receive .....6-3  
 ECM (Error Correction Mode) .....1-6  
 envelopes ..... 3-2, 3-3  
 error messages on LCD .....23-1  
 CHECK PAPER .....23-1  
 COMM. ERROR .....23-1  
 INK EMPTY .....2-12  
 NOT REGISTERED .....23-2  
 OUT OF MEMORY .....23-2  
 while scanning a document  
 ..... 7-4, 12-2  
 extension telephone, using .....6-5  
 external telephone .....2-13  
 cordless ..... 2-13, 6-5  
 external two-line TAD .....2-16

## F

fax  
 codes  
 Fax Receive Code ..... 6-3, 6-5  
 Remote Retrieval Access Code ...10-3  
 Telephone Answer Code .....6-5  
 troubleshooting .....6-5  
 receiving .....6-1  
 difficulties .....23-7  
 erasing from the memory .....10-4  
 forwarding ..... 10-1, 10-4  
 Polling .....6-6  
 reducing to fit on paper .....6-4  
 retrieving from a remote site .....10-5  
 Ring Delay, setting .....6-2  
 sending  
 automatic fax redial .....7-4  
 automatic transmission .....7-3

canceling from memory ..... 7-6  
 color fax ..... 7-4  
 contrast ..... 7-2  
 cover page ..... 7-7  
 delayed ..... 7-10  
 from memory (dual access) ..... 7-4  
 manual transmission ..... 7-3  
 overseas ..... 7-9  
 Polled Transmit ..... 7-11  
 Real Time Transmission ..... 7-5  
 resolution ..... 7-3  
 Fax Forwarding ..... 10-1  
 changing remotely ..... 10-4, 10-5  
 programming a number ..... 10-1  
 Fax Storage ..... 10-2  
 printing from ..... 6-6  
 setting ..... 10-2  
 FAX/TEL receive mode ..... 6-3  
 answering voice calls ..... 6-5  
 double-ringing (voice calls) ..... 6-3  
 receiving faxes ..... 6-3  
 FCC notices ..... 22-1

## G

gray scale ..... S-1  
 Groups (for Broadcasting) ..... 8-3

## H

Hearing aid compatible ..... 5-6, 22-1  
 HELP ..... 4-1, 11-2

## I

Importing ..... 17-14  
 ink cartridges ..... 2-1, 2-10, 2-11, 2-12  
 installing ..... 2-9  
 replacing ..... 23-17  
 Ink Dot Counter ..... 23-17  
 ink management ..... 1-3, 23-10

## J

- jack ..... 2-15, 2-16
  - convert to RJ11 wall jack .....2-16
- EXT. jack
  - external telephone .....2-13
  - cordless phone .....2-13
  - TAD (answering machine) .....2-13
  - two-line telephone or TAD .....2-16
- triplex adapter .....2-16

## L

- LCD (Liquid Crystal Display) ..... 1-3, 4-1

## M

- Macintosh® G3, G4 or iMac™ or iBook™ .....21-1
- maintenance, routine .....23-16
- manual
  - dialing .....8-4
  - fax receive .....6-1
  - transmission .....7-3
- Menu mode .....4-1
  - programming at-a-glance .....4-1
- multi-line connections (PBX) .....2-17

## O

- One Touch numbers
  - accessing with Shift key .....8-1
  - changing .....8-2
  - dialing .....8-5
  - storing .....8-1
- Options key (copying) ..... 12-2, 12-3
- OUT OF AREA .....9-3

## P

- packing list .....2-1
- Paging ..... 10-1, 10-2
  - programming your pager number ...10-1
- paper
  - capacity .....3-2
  - jam .....23-4
  - size .....5-1

- specification .....3-2
- Paper Tray .....2-5
  - loading paper .....2-8
- PaperPort (6.5)
  - accessing .....17-1
  - exporting .....17-14
  - importing .....17-14
  - uninstall .....17-11
- PaperPort (8.0)
  - accessing .....17-6
  - exporting .....17-19
  - importing .....17-18
- PBX .....2-17
- PC FAX (For Windows®) .....19-1
  - sending
    - address book .....19-5
    - cover page .....19-10
    - facsimile style .....19-12
    - group .....19-7
    - setting up .....19-1
    - simple style .....19-13
- phone line difficulties .....23-7
- Polled Transmit .....7-11
- Polling .....6-6
- power failure .....5-7
  - memory storage .....5-7
- print .....7-9
  - area .....3-3
  - difficulties .....23-7
  - fax from memory .....6-6
  - improving print quality .....23-10
  - jam .....23-4
  - resolution .....S-2
  - specifications .....S-2

## R

- Receive mode
  - FAX ONLY .....6-1
  - FAX/TEL .....6-1
  - MANUAL .....6-1
  - TAD
    - ANSWER MACH. ....6-1
- Redial/Pause .....7-4, 8-7

remote codes for extension phones .....6-5  
 Remote Fax Options .....10-1  
 Remote Setup .....18-1  
 Reports .....11-1  
 resolution  
   fax (standard, Fine, SuperFine, Photo,  
   color fax) ..... S-1  
   setting for the next fax .....7-3  
 Ring Delay, setting .....6-2

**S**

safety instructions .....22-4  
 Scanning into PC  
   ScanSoft™ PaperPort® 6.5 .....17-11  
   ScanSoft™ PaperPort® 8.0 .....17-15  
   ScanSoft™ TextBridge® OCR  
   (98/98SE/Me/2000 Professional) ..17-13  
   Scansoft™ TextBridge® OCR (XP)  
   .....17-18  
 Search for stored numbers .....8-4  
 Secure Feed .....23-4  
 Setup  
   date and time .....5-2  
   Station ID (fax header) .....5-2  
 shipping the machine .....23-13  
 software  
   Brother Control Center .....15-1  
   ScanSoft™ Paper Port® .....17-11  
 special characters .....5-3  
 Speed Dial  
   changing .....8-2  
   dialing .....8-5  
   storing .....8-2

**T**

TAD (telephone answering device)  
   connecting ..... 2-13, 2-14  
   Receive Mode .....6-1  
   recording outgoing message .....2-15  
   two-line TAD .....2-16  
 text, entering ..... 5-3, 5-4  
 TextBridge® OCR .....17-11  
 Tone signals on Pulse line .....8-8  
 Transmission Verification Report .....11-2

troubleshooting ..... 23-1  
   error messages on LCD ..... 23-1  
   if you are having difficulty with ..... 23-7  
     incoming calls ..... 23-8  
     phone line ..... 23-7  
     printer ..... 23-8  
     printing or receiving faxes ..... 23-7  
     sending faxes ..... 23-8  
 two-line phone system .....2-15, 2-16, 2-17

**U**

Using the Options Key ..... 12-3

**V**

voice calls  
   FAX/TEL (double-ring) ..... 6-3  
 volume, setting  
   beeper ..... 5-4  
   handset ..... 5-6  
     amplify (for hearing-impaired) ..... 5-6  
   ring ..... 5-4  
   speaker ..... 5-5

**W**

Warranties ..... iii  
   Canada .....vi  
   Notice – Disclaimer ..... iii  
 World Wide Web .....i

# Remote Retrieval Access Card

If you plan to receive fax messages while away from your machine, carrying the Remote Retrieval Access Card printed below will serve as a convenient reminder of the retrieval procedures. Simply cut out the card and fold it to fit your wallet or organizer. Keeping it handy will help you derive the full benefit of your machine's forwarding, paging and remote retrieval features.

**REMOTE RETRIEVAL ACCESS CARD**

**CHECK RECEIVING STATUS**  
Press **971**  
1 long beep — Fax message(s)  
3 short beeps — No messages

**CHANGE ANSWER MODE**  
Press **98**  
*then for* TAD, press **1**.  
FAX/TEL, press **2**.  
FAX, press **3**.

**EXIT REMOTE OPERATION**  
Press **90**.

**Using Remote Retrieval Access Code**

- 1 Dial your fax number from a fax machine using touch tone.
- 2 When your MFC answers, immediately enter your Remote Retrieval Access Code (159★).
- 3 Your MFC signals the kinds of messages received:  
1 long beep — Fax message(s)  
No beeps — No messages.
- 4 After 2 short beeps, enter a command.
- 5 Press **90** to reset your MFC when you finish.
- 6 Hang up.

Fold →

← Fold

1

4

### Changing Remote Retrieval Access Code

- 1 Press **Menu/Set 2, 5, 3**.
- 2 Enter a three-digit number from 000 to 999.  
The \* cannot be changed.
- 3 Press **Menu/Set**.
- 4 Press **Stop/Exit**.

### Remote Commands

#### CHANGE PAGING/FAX FORWARDING SETTING

- Press **9 5**.  
*then to* Turn feature off, press **1**.  
Select Fax Forwarding, press **2**.  
Select Paging, press **3**.

**Program Fax Forwarding Number**, press **4**. Enter the new fax number where you want your fax messages forwarded followed by **##**.

**Turn Fax Storage on**, press **6**

**Turn Fax Storage off**, press **7**.

#### RETRIEVE A FAX

Press **9 6**

*then to*

**Retrieve all faxes**, press **2**.

*then enter the number of remote fax machine followed by ##.*

After the beep, hang up and wait.

**Erase all fax messages**, press **3**.

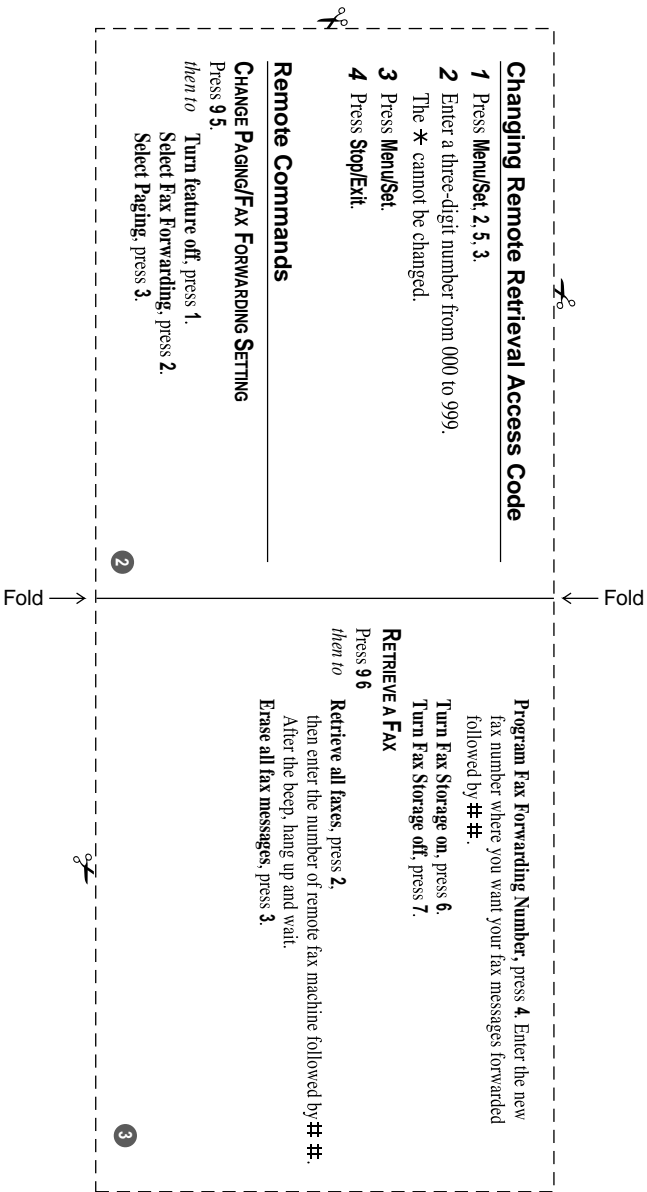



## **EQUIPMENT ATTACHMENT LIMITATIONS (Canada only)**

### **NOTICE**

This equipment meets the applicable Industry Canada Terminal Equipment Technical Specifications. This is confirmed by the registration number. The abbreviation, IC, before the registration number signifies that registration was performed based on a Declaration of Conformity indicating that Industry Canada technical specifications were met. It does not imply that Industry Canada approved the equipment.

### **NOTICE**

The Ringer Equivalence Number (REN) for this terminal equipment is 0.4. The REN assigned to each terminal equipment provides an indication of the maximum number of terminals allowed to be connected to a telephone interface. The termination on an interface may consist of any combination of devices subject only to the requirement that the sum of the Ringer Equivalence Numbers of all the devices does not exceed five.

# brother®

Brother International Corporation  
100 Somerset Corporate Boulevard  
P.O. Box 6911  
Bridgewater, NJ 08807-0911 USA

Brother International Corporation (Canada) Ltd.  
1 rue Hôtel de Ville,  
Dollard-des-Ormeaux, QC, CANADA H9B 3H6

**Visit us on the World Wide Web  
<http://www.brother.com>**

These machines are made for use in the USA and CANADA only. We cannot recommend using them overseas because it may violate the Telecommunications Regulations of that country and the power requirements of your multi-function center may not be compatible with the power available in foreign countries. **Using USA or CANADA models overseas is at your own risk and may void your warranty.**

## Free Manuals Download Website

<http://myh66.com>

<http://usermanuals.us>

<http://www.somanuals.com>

<http://www.4manuals.cc>

<http://www.manual-lib.com>

<http://www.404manual.com>

<http://www.luxmanual.com>

<http://aubethermostatmanual.com>

Golf course search by state

<http://golfingnear.com>

Email search by domain

<http://emailbydomain.com>

Auto manuals search

<http://auto.somanuals.com>

TV manuals search

<http://tv.somanuals.com>