

signa® 5 plus whirlpool bath

the signa® whirlpool bath takes its name from the medieval central italian walled city, lastra a signa.



Like the walled city for which it is named, Signa® 5 was specially developed and designed for walled surround spaces.

whirlpool bath features:

- 4 fully adjustable TheraPro™ jets
- 4 directionally adjustable AccuPro™ jets
- RapidHeat™ in-line heater
- Electronic on/off control with temperature readout
- Patented Adjustable Silent Air™ Induction System
- Chromatherapy underwater lighting
- Contoured backrest
- PrO3™ Sanitation System

signa® 5 plus whirlpool bath

model number: BP81 - RH Pump
EP30 - LH Pump

exterior dimensions:
60" long x 42" wide x 22" high

interior dimensions:
41" long x 25" wide

of Jets/type of Jets:
4 TheraPro™ Jets
4 AccuPro™ Back Jets

operating gallons:
42 gallons





Signa™ 5 Plus Whirlpool Bath

Model: BP81, EP30

Ordering Information

Product Code:

BP81 Signa™ 5 Whirlpool Bath
Right Hand

- Center Drain Location
- Accessories / Hardware:
 - Trip-Lever Drain Kit #X559
 - Rotary Drain Kit, 26" Cable #8730
 - TheraPro™ Jet Rings Kit: #D095
 - AccuPro™ Jet Rings Kit (2Req'd): #P556
- Trim Kit Finishes Available:
 - (827) - Chrome
 - (898) - Brushed Chrome
 - (815) - Satin Nickel
 - (829) - Bright Brass
 - (805) - Platinum
 - (826) - Brushed Nickel
 - (845) - Oil Rubbed Bronze

Installation Notes

Refer to installation instructions included with fixture before beginning installation. Please confirm product availability and specifications before commencing with any installation work.

PRODUCT SPECIFICATIONS AND AVAILABILITY ARE SUBJECT TO CHANGE WITHOUT NOTICE.

Technical Specifications

Dimensions

60" L x 42" W x 22" H
(1524 mm) L x (1067 mm) W x (559 mm) H

Drain/Overflow

A: 17-1/2" (445 mm) B: 12-1/2" (318 mm)

Cutout

58" x 40"

Total Weight

708 lb (321 kg) / 40 lb/sq. ft. (197 kg/m²)

Operating Gallonage

42 U.S. Gal. (159 Liters)
Max. 82 U.S. Gal. (310 Liters)

Product Weight

108 lb (49 kg)

Skirt Mounting

Optional, U-Frame

Electrical Specifications

Requires a dedicated GFCI protected separate circuit.

Motor/Pump: 120 VAC, 15 AMP, 60 Hz.

RapidHeat™: 120 VAC, 15 AMP, 60 Hz.

Heater (Standard)

Requires a dedicated GFCI protected separate circuit.

RapidHeat™: P/N S750000

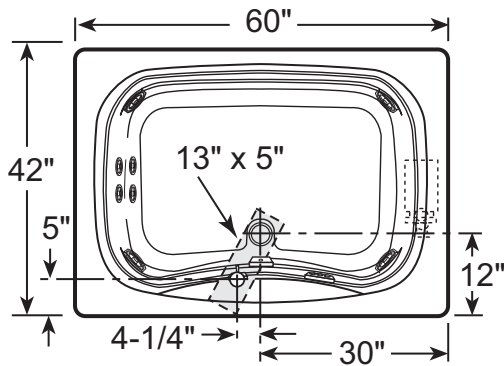

Product Shown: Signa™ 5 Plus Whirlpool Bath Right Hand Model: BP81

* Measurements inside unit represent cutout in floor to allow for drain/overflow.

Minimum Service Access dimensions given.

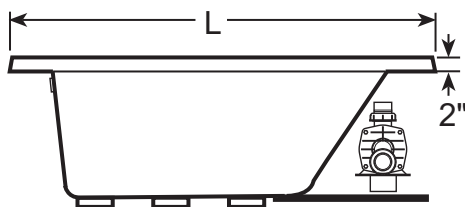

SIDE VIEW

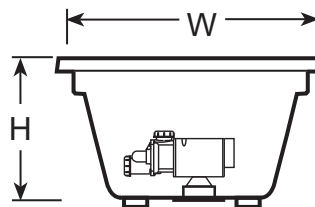

FND VIEW

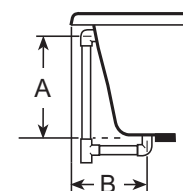

DRAIN/OVERFLOW

Free Manuals Download Website

<http://myh66.com>

<http://usermanuals.us>

<http://www.somanuals.com>

<http://www.4manuals.cc>

<http://www.manual-lib.com>

<http://www.404manual.com>

<http://www.luxmanual.com>

<http://aubethermostatmanual.com>

Golf course search by state

<http://golfingnear.com>

Email search by domain

<http://emailbydomain.com>

Auto manuals search

<http://auto.somanuals.com>

TV manuals search

<http://tv.somanuals.com>