

MCCULLOCH

 Electrolux

PRO MAC 54 54CC PRO MAC 61 59CC

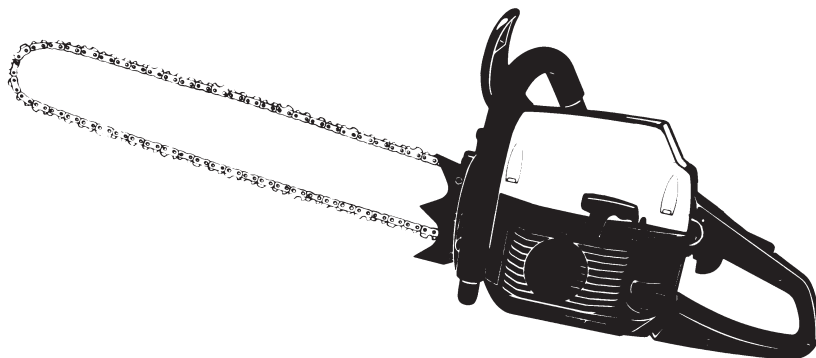

GB

INSTRUCTION MANUAL

IMPORTANT INFORMATION: Please read these instructions carefully and make sure you understand them before using this unit. Retain these instructions for future reference.

DE

BETRIEBSANWEISUNG

WICHTIGE INFORMATION: Lesen Sie diese Hinweise zur Handhabung des Geräts aufmerksam durch. Verwenden Sie es erst, wenn Sie sicher sind, daß Sie alle Anweisungen verstanden haben und gut aufbewahren.

FR

MANUEL D'INSTRUCTIONS

RENSEIGNEMENTS IMPORTANTS: Avant d'utiliser cet appareil, veuillez lire attentivement les instructions et assurez-vous de les avoir comprises. Conservez les instructions pour référence ultérieure.

NL

HANDLEIDING

BELANGRIJKE IMPORTANTS: Lees deze handleiding aandachtig en zorg dat u alles begrijpt alvorens de kettingzaag te gebruiken en bewaar ze voor toekomstige raadpleging.

NO

BRUKERHÅNDBOK

VIKTIG INFORMASJON: Les disse anvisningene nøye og forsikre deg om at du forstår dem før du bruker enheten og oppbevar dem for senere bruk.

FI

OHJEKIRJA

TÄRKEÄÄ TIETOA: Lue nämä ohjeet huolellisesti ja varmista, että olet ymmärtänyt ne, ennen kuin alat käyttää tätä laitetta ja säilytä myöhempää tarvetta varten.

SE

BRUKSANVISNING

VIKTIG INFORMATION: Läs instruktionerna noggrant och försäkra dig om att du förstår dem innan du använder utrustningen och spara dem för framtida behov.

DK

BRUGERHÅNDBOG

VIGTIGE OPLYSNINGER: Læs instruktionerne omhyggeligt, før du bruger enheden og gemme til senere henvisning.

ES

MANUAL DE INSTRUCCIONES

INFORMACIÓN IMPORTANTE: Lea atentamente las instrucciones y asegúrese de entenderlas antes de utilizar esta aparato. Conserve las instrucciones para la referencia en el futuro.

PT

MANUAL DO OPERADOR

INFORMAÇÕES IMPORTANTES: Queira ler cuidadosamente estas instruções e tenha certeza de entendê-las antes de usar a serra e guarde para consulta futura.

IT

LIBRETTO D'ISTRUZIONI

INFORMAZIONI IMPORTANTI: Leggere le istruzioni attentamente e capirle bene prima di usare la motosega. Conservare per ulteriore consultazione.

GR

ΕΓΧΕΙΡΙΔΙΟ ΧΡΕΙΣΜΟΕ

ΣΗΜΑΝΤΙΚΕΣ ΠΛΗΡΟΦΟΡΙΕΣ: Διαβάστε προσεκτικά αυτές τις οδηγίες και φροντίστε να τις κατανοήσετε πριν χρησιμοποιήσετε αυτό το μηχάνημα και φυλάξτε το για να το συμβουλευτείτε στο μέλλον.

HU

HASZNÁLATI ÚTMUTATÓ

Jótállást vállalni csak rendeltetés szerűen használatba vett gépekre tudunk. Kérjük, hogy a gép használatba vétele előtt gondosan olvassa el a kezelési utasításokat.

A.

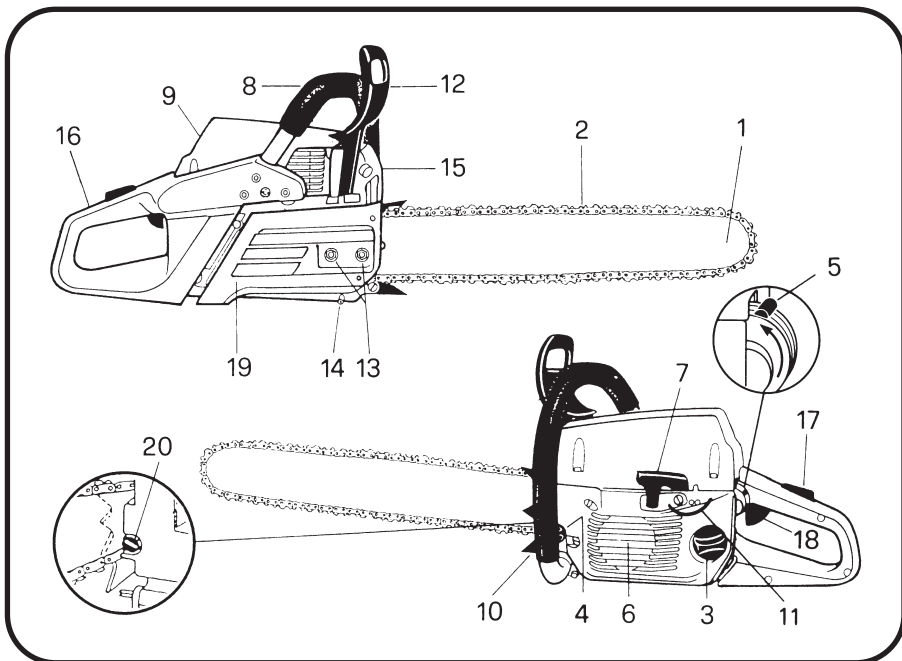

B.

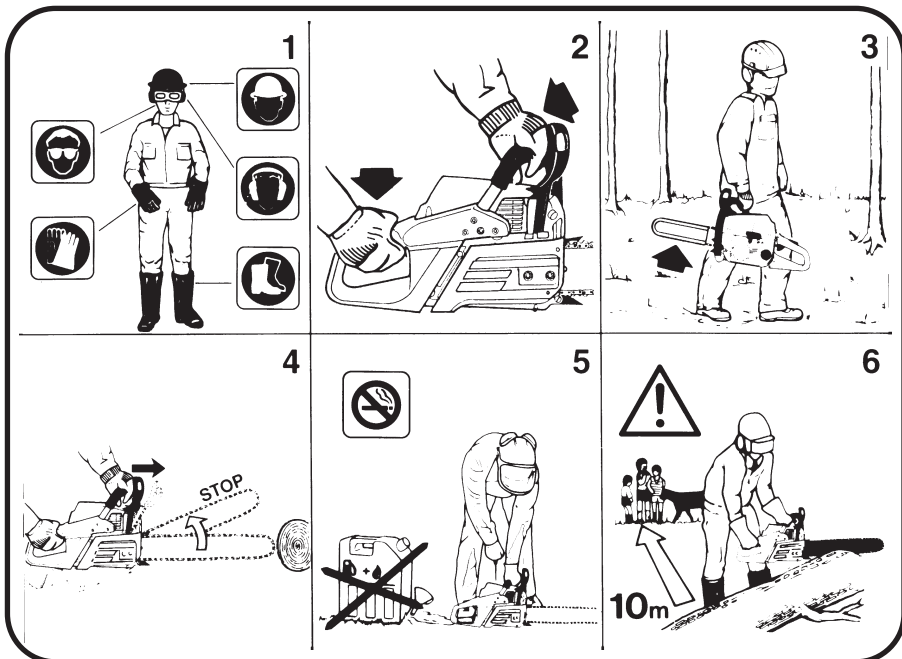

C.

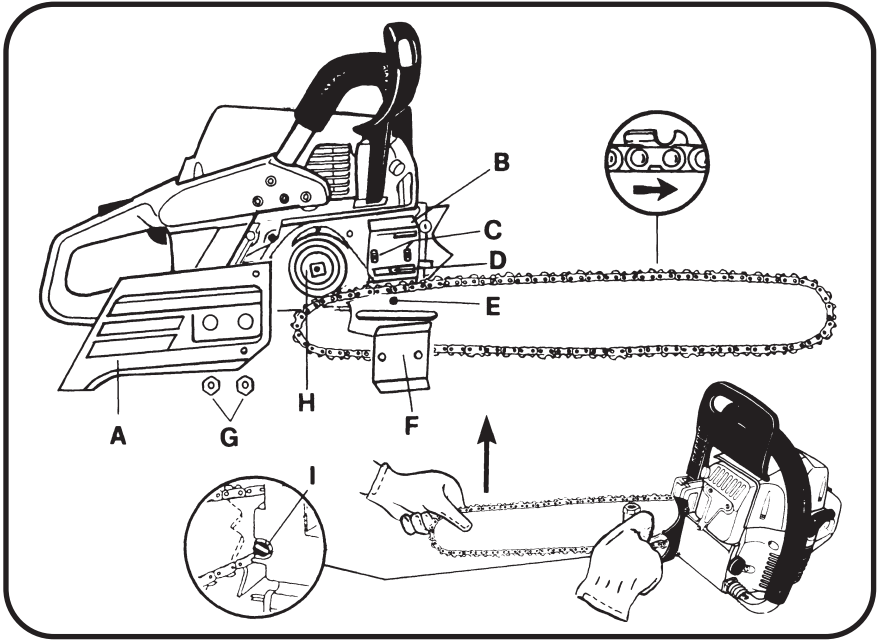

D.

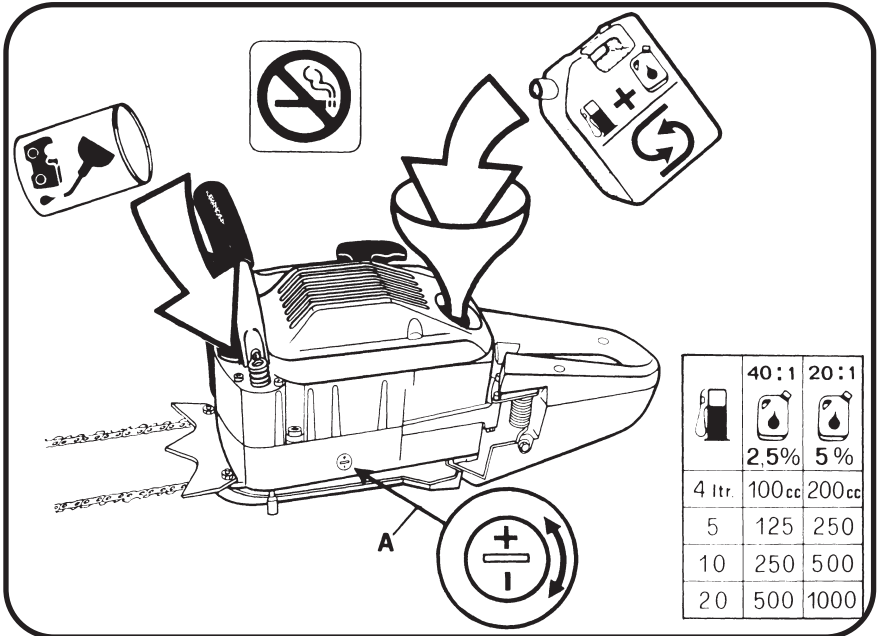

E.

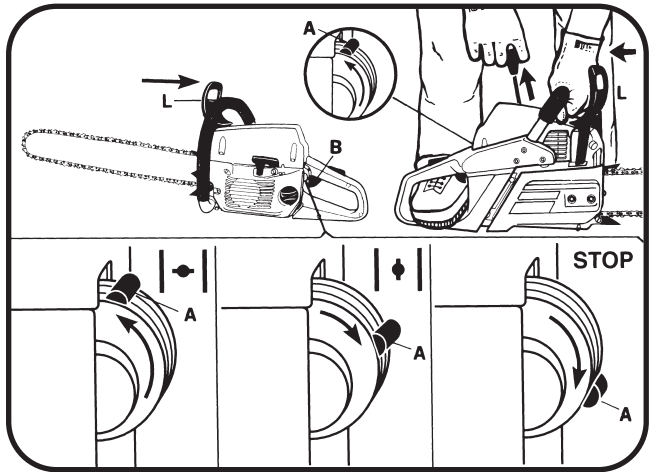

F.

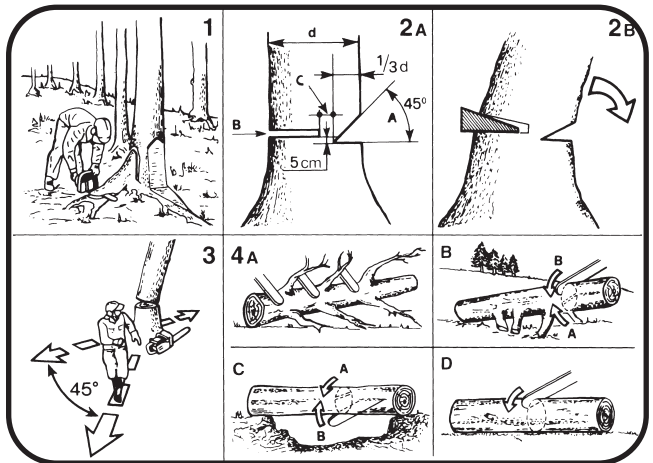

G.

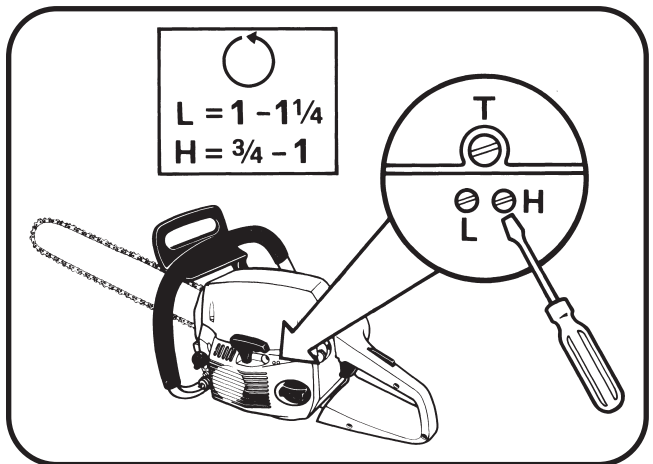

H.

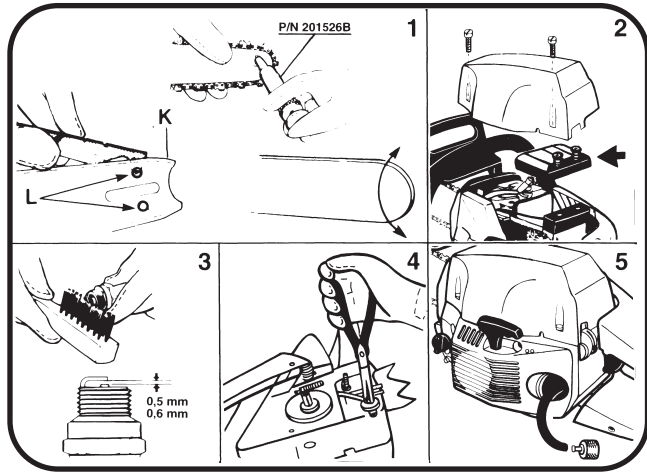

I.

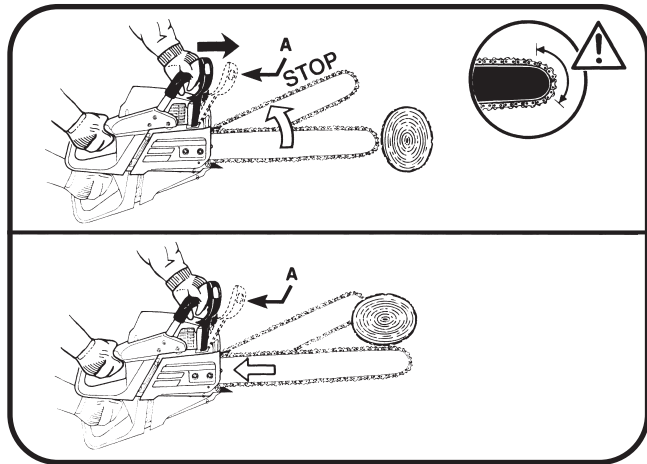

L.

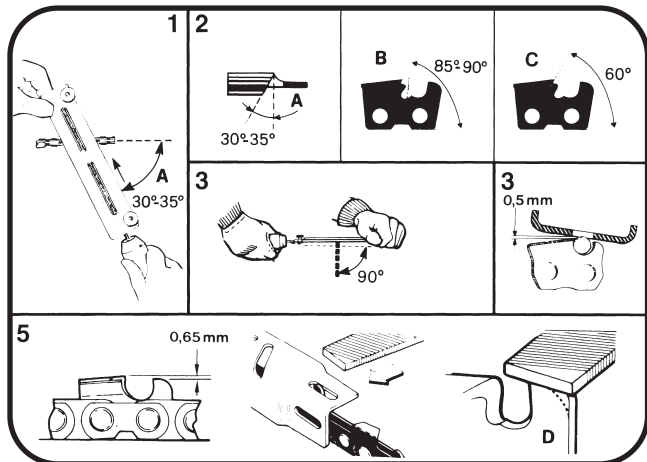

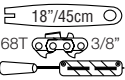
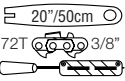
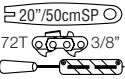
	PRO MAC 54	PRO MAC 61
 <p>18"/45cm 68T 3/8"</p>	<p>225735B 225739B 86826B (7/32")</p>	<p>225735B 225739B 86826B (7/32")</p>
 <p>20"/50cm 72T 3/8"</p>	<p>225736B 225740B 86826B (7/32")</p>	<p>225736B 225740B 86826B (7/32")</p>
 <p>20"/50cmSP 72T 3/8"</p>		<p>225737B 225740B 86826B (7/32")</p>

- GB** Due to a constant product improvement programme, the factory reserves the right to modify technical details mentioned in this manual without prior notice.
- DE** Im Sinne des Fortschritts behält sich der Hersteller das Recht vor, technische Änderungen ohne vorherigen Hinweis durchzuführen.
- FR** La Maison se réserve la possibilité de changer des caractéristiques et des données de ce manuel à n'importe quel moment et sans préavis.
- NL** Door konstante produkt ontwikkeling behoudt de fabrikant zich het recht voor om technische specificaties zoals vermeld in deze handleiding te veranderen zonder hiervan vooraf bericht te geven.
- NO** Produsenten forbeholder seg all rett og mulighet til å forandre tekniske detaljer i denne manualen uten forhåndsvarsel.
- FI** Jatkuvan tuotteen parannusohjelman tähden valmistaja pidättää oikeuden vaihtaa ilman ennakkovaroitusta tässä ohjekirjasessa mainittuja teknisiä yksityiskohtia.
- SE** Tilverkaren reserverar sig rätten att ändra fakta och uppgifter ur handboken utan förvarning.
- DK** Producenten forbeholder sig ret til ændringer, hvad angår karakteristika og data i nærværende instruktion, når som helst og uden varsel.
- ES** La firma productora se reserva la posibilidad de cambiar las características y datos del presente manual en cualquier momento y sin previo aviso.
- PT** A casa productora se reserva a possibilidade de variar características e dados do presente manual em qualquer momento e sem aviso prévio.
- IT** La casa produttrice si riserva la possibilità di variare caratteristiche e dati del presente manuale in qualunque momento e senza preavviso.
- GR** Λόγω προγράμματος συνεχούς βελτίωσης προϊόντων, το εργοστάσιο επιφυλάσσει το δικαίωμα να τροποποιεί τις τεχνικές λεπτομέρειες που αναφέρονται στο εγχειρίδιο αυτό χωρίς προηγούμενη ειδοποίηση.
- HU** Folyamatos gyártmány felújítási műsorunk következtében, a gyártó cég fenntartja a jogát ebben a Használati leírt műszaki adatok előzetes értesítés nélküli változtatására.

SPECIFICATIONS

THIS PRODUCT MEETS THE SAFETY STANDARD REQUIREMENT OF THE EUROPEAN MACHINERY DIRECTIVE

DISPLACEMENT (cm ³)	54	59
BORE AND STROKE (mm).....	45x34	47x34
ENGINE OUTPUT (kW).....	2,6	2,82
ENGINE SPEED AT MAX POWER (min ⁻¹)	8.200	8.200
MAXIMUM SPEED (min ⁻¹)	11.000	11.000
MINIMUM SPEED (min ⁻¹)	2.500	2.500
DRY WEIGHT (Kg) (NO BAR AND CHAIN)	6,25	6,25
CHAIN PITCH (9,525 mm).....	3/8"	3/8"
CHAIN GAUGE (mm).....	1,5	1,5
BAR LENGTHS (cm).....	45/50	45/50
No. OF SPROCKET TEETH	7	7
OIL TANK CAPACITY (cm ³).....	390	390
FUEL TANK CAPACITY (cm ³).....	590	590
SOUND PRESSURE LEVEL (AT THE OPERATOR'S EAR), LpAav (dBA) (EN 27182 - EN 608) ...	101	101
SOUND POWER LEVEL LwAav (dBA) (ISO 9207 - EN 608)	109	109
VIBRATION LEVEL (ISO 7505 - EN 608) (m/s ²).....	9,25	8,02

DATI TECNICI

QUESTO PRODOTTO È CONFORME ALLA DIRETTIVA EUROPEA SULLA SICUREZZA DELLE MACCHINE

CILINDRATA (cm ³)	54	59
ALESAGGIO x CORSA (mm)	45x34	47x34
POTENZA (kW)	2,6	2,82
REGIME DI MASSIMA POTENZA (min ⁻¹)	8.200	8.200
REGIME MASSIMO (min ⁻¹)	11.000	11.000
REGIME DI MINIMO (min ⁻¹)	2.500	2.500
PESO A SECCO (Kg) (SENZA BARRA E CATENA)	6,25	6,25
PASSO CATENA (9,525 mm)	3/8"	3/8"
SPESSORE CATENA (mm).....	1,5	1,5
LUNGHEZZA BARRA (cm).....	45/50	45/50
No. DENTI DEL PIGNONE	7	7
CAPACITÀ SERBATOIO OLIO (cm ³)	390	390
CAPACITÀ SERBATOIO MISCELA (cm ³)	590	590
PRESSIONE SONORA ALL'ORECCHIO DELL'OPERATORE LpAav (dBA) (EN 27182 - EN 608).	101	101
POTENZA SONORA LwAav (dBA) (ISO 9207 - EN 608).....	109	109
VIBRAZIONI (ISO 7505 - EN 608) (m/s ²)	9,25	8,02

CARACTÉRISTIQUES TECHNIQUES

CE PRODUIT EST CONFORME À LA NORME EUROPÉENNE POUR LA SÉCURITÉ DES MACHINES

CYLINDRÉE (cm ³).....	54	59
ALÉSAGE / COURSE (mm).....	45x34	47x34
PUISSANCE MOTEUR (kW).....	2,6	2,82
REGIME MOTEUR PUISSANCE MAX (min ⁻¹).....	8.200	8.200
REGIME MAXIMUM (min ⁻¹)	11.000	11.000
REGIME DE RALENTI (min ⁻¹)	2.500	2.500
POIDS A VIDE (Kg) (SANS BARRE NI CHAÎNE)	6,25	6,25
PAS DE LA CHAÎNE (9,525 mm)	3/8"	3/8"
JAUGE (mm).....	1,5	1,5
LONGUEUR DE GUIDE (cm).....	45/50	45/50
NOMBRE DES DENTS DE PIGNONS	7	7
CAPACITÉ DU RÉSERVOIR HUILE (cm ³)	390	390
CAPACITÉ DU RÉSERVOIR ESSENCE (cm ³).....	590	590
PRESSION SONORE À L'OREILLE DE L'OPERATEUR. LpAav (dBA) (EN 27182 - EN 608).....	101	101
NIVEAU DE BRUIT LwAav (dBA) (ISO 9207 - EN 608)	109	109
VIBRATIONS (ISO 7505 - EN 608) (m/s ²)	9,25	8,02

SYMBOL MEANING



Read operator's manual carefully

Wear safety clothing:



1 Approved safety glasses or face shield



2 Approved safety helmet



3 Approved ear defender



4 Approved gloves



5 Approved safety footwear



Do not smoke while refuelling or while operating the machine



Warning - Caution



Choke fully opened (not start / run)



Choke partially opened



Choke closed (cold start)



Brake engaged / disengaged



Beware of kickback



Do not cut with the end on the bar, this may cause kickback



Never use the machine with only one hand



Always use the machine with both hands

GENERAL DESCRIPTION

A

- 1 - BAR
- 2 - CHAIN
- 3 - FUEL TANK CAP
- 4 - OIL TANK CAP
- 5 - STOP / RUN LEVER
- 6 - STARTER HOUSING
- 7 - STARTER HANDLE
- 8 - FRONT HANDLE
- 9 - AIR FILTER COVER
- 10 - SPIKE/SPACER
- 11 - CARBURETOR ADJUSTMENT SCREWS
- 12 - SAFETY CHAIN BRAKE
- 13 - BAR RETAINING NUTS
- 14 - CHAIN CATCHER
- 15 - MUFFLER SHIELD
- 16 - REAR HANDLE
- 17 - THROTTLE TRIGGER LOCKOUT
- 18 - THROTTLE TRIGGER
- 19 - CHAIN BRAKE COVER
- 20 - CHAIN ADJUSTER SCREW

SAFETY PRECAUTIONS

B

- 1 All operators should read this manual carefully before using this chainsaw; only use this machine for usage specifically mentioned in this manual.**

Wear suitable clothing. This should include snugly-fitting (safety) clothing, sturdy boots, heavy duty gloves, goggles or a face screen and ear plugs or ear muffs. Wear a helmet if there is risk of falling objects or projections from trees.

- 2** Always hold the chainsaw firmly with both hands when the engine is running. Always maintain a firm foothold. Ensure you are able to stop the engine quickly if necessary. Do not work up a tree unless you have received suitable training and have the appropriate equipment (belts, ropes, safety hooks etc.) for this type of work.

We strongly recommend that all first-time chainsaw users obtain practical instruction on safe chainsaw usage before operating the chainsaw.

Do not operate this machine when tired or under the influence of any substances, drugs or alcohol which can impair vision, dexterity or judgement.

Prolonged use of chainsaws or other machines exposing the operator to vibration may produce Whitefinger's Disease (Raynaud's Phenomenon). This may reduce the hands' ability to feel and regulate temperature and may

produce general numbness. Continual or regular users should therefore monitor closely the condition of their hands or fingers. If any of the symptoms appear, seek immediate medical advice.

- 3 Never carry the chainsaw with the engine running. Whenever carrying a chainsaw, even for short distances, the chain should be covered by the chain guard (scabbard) and the bar should point backwards. When transporting the chainsaw in a vehicle, secure the saw to prevent fuel spillage.
 - 4 To avoid kick-back, do not attempt to cut with the nose of the bar. Ensure the engine is running at full throttle before commencing to cut. To avoid kick-back, do not let the nose of the bar come into contact with logs, branches, the ground or any other obstruction. Do not allow any part of the chain to come into contact with rock, nails or wire fence. Ensure the chain is kept sharp and correctly tensioned. Keep the spike or the saw body against the wood when cutting. Use only genuine accessories and spare parts. We recommend you have your unit periodically checked and serviced by an authorised dealer. Do not use chainsaw above shoulder height.
 - 5 Do not operate the chainsaw near a naked flame or spilled fuel. Only operate the chainsaw outside and in well ventilated areas. After re-fuelling, always wipe off any spilled fuel. Move the chainsaw away from the fuelling point before starting the engine.
 - 6 Keep by-standers and animals out of the work area; at a minimum distance of 10 m or twice the timber length. If necessary, use warning signs to keep on-lookers at a distance. Carefully survey the working site to note any hazards, eg. roads, paths, electricity cables, dangerous trees etc. Do not use the chainsaw if the device for stopping the chain (safety chainbrake) does not work correctly. Never place hands on the chain whilst the engine is running. Ensure someone is within hearing distance in case of an accident. If this is not possible, it is recommended that users operating chainsaws in remote areas carry an adequate first-aid kit with them and ensure someone knows their location. Never leave the engine running while the tool is unattended.
- ONLY USE ORIGINAL SPARE PARTS AND ACCESSORIES.**

BAR AND CHAIN INSTALLATION

C

Ensure engine is always switched off before fitting or adjusting chain. Wear a pair of protective gloves when fitting or adjusting chain.

- A. Clutch guard
- B. Inner bar plate
- C. Bar mounting bolts
- D. Chain tensioning screw
- E. Oil hole
- F. Outer bar plate
- G. Bar retention nuts
- H. Sprocket
- I. Adjusting screw

Remove the clutch guard (A) and the outer bar plate (F). Check that the oil hole (E) is free from impurities. Fit the chain over the sprocket (H). Ensure correct direction of cutter tooth. Put the bar in position over studs (C) slide it towards the sprocket. Fit the chain into the bar groove and slide the bar forwards.

Make sure that the tang chain tensioning screw (D) fits into the hole in the bar (E). Replace the outer bar plate and the clutch guard. Screw the two bar retention nuts finger tight (G). Tension the chain by turning the adjusting screw (I) clockwise while raising the tip of the bar. The tension is sufficient if the chain is snug on the bar but still moves freely around the bar when pulled by hand. Tighten the two bar retention nuts securely.

Always use the combination tool to install and tension the chain.

RUNNING IN A NEW CHAIN

The chain must always be cold when carrying out adjustment.

- 1 Let the chain run slowly for a few minutes. Check that the oil pump is delivering oil onto the chain.
- 2 Stop the engine and adjust the chain tension.
- 3 Check the tension of a new chain more frequently during initial usage and adjust as necessary.
- 4 Repeat adjusting until the chain does not stretch any more. **Never touch the chain while the engine is running.**

FUEL MIX

D

Use only fuel recommended by this manual. This product is fitted with a 2-stroke engine and therefore requires a 2-stroke petrol and oil mix. Use leaded (4 Star) or unleaded petrol with a minimum octane rating of 90.

Only use oil from sealed containers. In order to obtain a good fuel mix, put the oil into the container before the petrol.

The use of sub-standard petrol or oil may reduce performance or reduce the life of certain components.

LEADED PETROL

If using leaded petrol, the correct fuel mix is achieved by either using 5% (20:1) of a well known brand of 2-stroke engine oil, or else 2.5% (40:1) of special McCulloch engine oil.

UNLEADED PETROL

If using unleaded petrol, you must use a totally synthetic 2-stroke engine oil or McCulloch branded 2-stroke engine oil. In either case use 2.5% (40:1) of oil.

IMPORTANT

Always shake this fuel mix vigorously each time you use it. We recommend to carry out this operation each time you use the fuel.

Fuel mix properties deteriorate with time, we therefore recommend that you only make the quantity of fuel mix you will need for each usage. Do not use fuel mix more than a week old as this could damage the engine.

WARNING

Do not smoke when re-fuelling.
 Always open the fuel cap slowly.
 Re-fuel in open spaces only, keeping away from naked flames or sparks.
 Always store fuel in an approved container.

SAFE STORAGE OF FUEL

Petrol is highly inflammable. Put out all cigarettes, pipes and cigars before working with petrol. Avoid spilling petrol. Store fuel in a cool, well ventilated place, in an approved container specifically designed for the purpose.
 Never store engine with fuel in the tank in enclosed, poorly ventilated areas, where fuel fumes may reach an open flame, spark or pilot light such as in a furnace, water heater, clothes dryer etc. Petrol fumes can cause an explosion or a fire. Do not store large amounts of fuel.

CHAIN LUBRICATION

IMPORTANT

The service life of the bar and chain depends on good lubrication.

Always use chain lubricating oil of medium viscosity. We recommend special McCulloch chain lubricating oil.
 Never use waste oil for this purpose. This results in damage to the bar, the chain and the oil pump.
 Refill the chain oil tank each time the saw is refuelled.

IMPORTANT

The chain oil feed is reduced to a minimum when the regulating bolt is completely closed (turning clockwise)

To prevent possible restarting problems avoid running the fuel tank dry. This also helps to extend engine life.

NOTE: Saw chain stretches during use particularly when it is new, and it will occasionally be necessary to adjust and tighten it. A new chain will require adjustment after about 5 minutes of operation.

- The mechanical oil pump for chain lubrication can be adjusted.

The feed rate of the chain oil pump can be adjusted by means of the regulating screw (A) (see details in the illustration). The oil feed rate is increased by turning the regulation bolt counterclockwise ☺.

IMPORTANT - The chain oil feed is reduced to a minimum when the regulating bolt ☺ is completely closed (turning clockwise).

STARTING AND STOPPING E

IMPORTANT. Never start or operate unless bar and chain are properly installed.

Before starting always move the saw away from the felling area and place it on firm, flat surface, the guide bar to the front.

STARTING COLD ENGINE

Check that the chain brake is in the disengaged position moving the lever (L) backwards (towards the front handle).
 Move the stop/run lever (A) up to the cold start position (choke closed ☞) When in the cold start position, this lever also partially opens the throttle.

Hold the saw firmly as shown in illustration and pull the starter rope until the engine fires once.

Once you hear the engine start, or attempt to start, move the stop/run lever (A) to the intermediate position (choke open ☞).
 ⚠

ATTENTION: The throttle remains partially open in this position and the chain may run. This allows the engine to warm up.

Pull the starter rope until the engine starts.
 Allow engine to warm up for a few seconds, holding the saw firmly.

Beware of moving chain.

ATTENTION: Squeeze and then release the accelerator trigger (B). This will allow the throttle too close and the chain should no longer move.

STOP

To stop the engine, move the stop/run lever (A) down, to the "STOP" position.

IMPORTANT. After lengthy use of the chain saw at full speed, we recommend to run the engine for a few seconds at idle speed before stopping it.

STARTING A WARM ENGINE

Leave the start/run lever (A) onto the run position (in the middle). Pull the starter handle until the engine runs.

IMPORTANT: The automatic accelerator opening system will only function if the start/run lever (A) is moved up to the cold start position, and then back down to the run position (in the middle). Do this if the engine fails to run after starting.

STARTING A WARM ENGINE AFTER FUELLING

In the fuel tank as run completely dry, procede to start as with a cold engine.

USAGE F

IMPORTANT

Before using a chain saw read the Operator's Manual and all safety precautions carefully.

FELLING TREES

- Make sure that there are no bystanders or animals in the work area.
- Study the direction of the fall of the tree and then plan your exit path away from the planned direction of fall.
- Don't fell trees when there is a strong wind.

1 Clear the tree base of interfering limbs and brush. Clean the work area from stones or other objects which could damage the chain. If the tree has large protruding roots, remove them before felling (see illustrations).

2 A) Cut a felling notch (A) of 45° on the side you want the tree to fall to a depth of about one third of the trunk diameter (d). Then make a felling cut (B) about 5 cm higher than the felling notch on the opposite side of the tree. Make sure that the felling cut does not go right through the trunk. A hinge (C) must always be left to provide control over the direction of the fall.

- B) Use wedges to control the moment and direction of the fall.
- 3 When the tree starts to fall, walk away along your preplanned escape path.

CUTTING FALLEN TRUNKS

- 4 A) **Limbing thick branches.** For limbing and bucking leave the lower limbs to support the log off the ground.
- B) **Supported at one end only.** Begin with a bottom cut made by the upper side of the bar (A); the depth of the cut should be about one third of the log diameter. Finish with a top cut (B) meeting the first one. With this technique splitting, cracking can be avoided
- C) **Supported at both ends.** Begin with a top cut about one third of the log diameter. Then finish with a bottom cut (B) meeting the first one. this technique avoids the risk of pinching the bar in the log.
- D) If the log is supported along its whole length it may be cut normally from above. Take care not to touch the ground with the chain.
- When working on a slope always stand on the uphill.
 - When cutting prepared timber, use clamps or chocks to secure work.
 - Use extreme caution when cutting small size brush and saplings which may catch the chain and pull you off balance.

CARBURETTOR ADJUSTMENT

G

We suggest carburetor adjustments are made by an authorised servicing dealer.

The carburetor has three adjustment screws:

- **L:** The needle screw **L** governs the fuel flow at low speed and also the acceleration from low to full speed.
To set screw **L**: close screw **L** turning it clockwise without forcing.
Then open screw 1-1/4 full turn (counterclockwise).
If acceleration is not smooth, open another 1/8 turn to increase fuel flow.
- **H:** The needle screw **H** governs fuel flow at high speed (throttle valve fully open).
To set hi speed screw **H**: close screw **H** turning it clockwise without forcing.
Then open screw 3/4-1 full turn (counterclockwise).
If the engine speed is too high, open the screw about 1/8 turn (counterclockwise).
- **I:** The **I** (IDLE) screw controls the throttle opening to govern idle speed adjust as necessary.

CAUTION: increased idle speed may cause chain movement. The carburetor is adjusted for normal operation during production. When considerable changes of altitude require a supplementary adjustment, contact an authorised service station which offers the latest in tools, parts and technical assistance.

ROUTINE MAINTENANCE

H

Ensure engine is always switched off before any kind of maintenance operation.

CHAIN: Check tension regularly. A new chain will require more frequent adjustment. Loosen retention nuts. Tighten chain (see assembly instructions). Tighten retention nuts and adjust.

1 BAR

- Clean the bar groove (K) and check the lubrication holes (L) in the bar to ensure that they are not clogged.
- Grease sprocket periodically. Rotate sprocket and repeat.
- Rotate bar periodically to maximise bar life.

2 AIR FILTER

- A dust clogged air filter may cause carburetor problems. This may prevent the engine from reaching its maximum r.p.m. and cause high fuel consumption.
- Remove cover.
- Wash filter in petrol (do not use fuel which is mixed with oil).
- The filter can also be cleaned with compressed air.
- Replace filter if damaged or if it does not seal tightly in the air box.

3 SPARK PLUG

- Remove and clean the spark plug every 30 hours. Check the electrode gap (0,5/0,6 mm. - 0.025 inches).
- Replace spark plug about every 100 working hours or whenever it is extremely encrusted.
 - Heavily encrusted electrodes can result from an incorrect carburetor setting or from wrong fuel mixture (too much oil in the fuel mix) or a poor quality of oil in the fuel mix. Check and correct.

4 OIL FILTER

The oil filter is on the end of the oil suction hose inside the oil tank.

Remove the chain catcher by twisting it anticlockwise and remove the oil filter. Use a piece of bent wire or long forceps. To remove deposits from the oil tank half-fill it with kerosene or petrol and shake thoroughly. Drain off and fill the tank with fresh saw chain oil.

Never use waste oil.

5 FUEL FILTER

To change fuel filter remove the tank cap and pull out the filter with a piece of bent wire or long forceps. Replace the filter as shown in the illustration and reposition it. It is recommended to replace the fuel filter at least once a year.

CHAIN BRAKE

- **WARNING:** Contact your service dealer if anything appears wrong with your chain brake. Do not disassemble or manipulate the mechanism of the chain brake.
- Clean the brake mechanism periodically (without disassembling it) and control the wear of the band visually.

- **PERIODICALLY:** It is important to clean the saw thoroughly particularly around cylinder fins to avoid overheating of the engine.

- **LONG STORAGE:** Empty fuel and run engine until dry.

SAFETY CHAIN BRAKE I

Your chain saw is fitted with a safety chainbrake designed to stop the chain in milliseconds in case of kickback. Always hold the saw firmly in both hands.

The chain brake does not provide a total protection if the machine is used without taking the necessary precautions and maintenances.

The chain brake is intended to engage automatically in case of kickback.

The chain brake can also be engaged manually by pushing the chain brake lever forwards. The manual use of the chain brake is recommended only at idle.

Always test the chain brake before using your saw. Do this by engaging the brake at idle (see below).

Always release the brake before starting.

Kickback may occur if the end of the bar (see illustrated angle) touches any solid object.

Never attempt to start a cut with the end of the bar.

Kickback is a violent upward and rearward movement of the bar and may cause you to lose control of the machine.

Therefore you should avoid starting a cut with this part of the bar. Always keep a firm grip on the saw with both hands because, in case of kickback, it is the contact of the left hand with the brake lever which will help to engage the brake.

CHAIN BRAKE TESTING:

- 1 The chain brake (A) is disengaged when brake lever is pulled back and locked(chain can move).
- 2 The chain brake (A) is engaged when brake lever is in the position (chain cannot rotate).The chain brake should snap into both positions.If strong resistance is felt or lever does not move into either position, DO NOT USE YOUR SAW. Take it immediately to an authorized servicing dealer.

3 CHAIN CATCHER

This unit is fitted with a chain catcher below the drive sprocket. This is intended to stop the rearward movement of the chain in case of breakage or if it should come out of the bar. It should never be removed.

CHAIN SHARPENING L

- 1 Chain cutter teeth can be sharpened with a round file, as follows:

CHAIN	FILE
SPR 378 GX	7/32"

The exact chain type is marked on the bottom half of the drive link which runs inside the bar groove.

Filing can be made easier by also using a file holder.

The chain can remain fitted on the bar during sharpening. Before commencing, the chain should be tensioned correctly and the chain brake should be activated to prevent the chain from moving.

- 2 To obtain a correct sharpening the file must be carefully held to maintain 3 basic angles:

- "A" Top angle	30° - 35°
- "B" External, side angle	85° - 90°
- "C" Internal, side angle	60°

File in one direction only, from the "inside" of the cutter tooth towards the "outside".

Do not allow the file to touch the chain as you bring it back to re-position it. Each cutter tooth should be filed with the same number of strokes.

- 3 The file should be held horizontally to the cutter tooth being sharpened.
- 4 Best results to obtain a precise sideways angle can be obtained by holding the file so that it rises 0,5 mm above the top face of the cutter tooth.

5 DEPTH GAUGE

Correct depth gauge height is vital to ensure maximum chain life and cutting efficiency.

The height of the depth gauge should be lowered as the cutter tooth is filed back; this height should be checked every 4 or 5 sharpenings.

The best way to do this is to use a flat file and a depth gauge tool.

The correct setting is 0.65 mm below the top edge of the cutter tooth.

The cutter tooth depth gauge should then be rounded (D).

FAULT FINDING TABLE

	Engine runs badly or loses power when cutting	Engine will not start	The machine runs but does not cut well
Check STOP switch is in the position I.	●		
Control fuel level min. 25% tank capacity.	●	●	
Check air filter is clean.	●	●	
Remove spark plug, dry it, clean it and adjust it, and replace it, if necessary.	●	●	
Control and adjust the carburetor screws if necessary.		●	
Change fuel filter. Contact your dealer.		●	
Carefully follow the cutting accessory assembly instructions.			●
Check chain is sharp. Otherwise, contact your dealer.			●

Engine still gives trouble: contact your dealer.

GB EC Declaration of Conformity

The undersigned, authorised by E.O.P.I., declares that the petrol-driven chainsaw **MS55, MS60**, manufactured by E.O.P.I., 23868 Valmadrera (LC), Via Como 72, Italy, is in accordance with the European Directives **98/37/CEE** (Machinery Directive), **73/23/EEC** (Low Voltage Directive), **93/68/CEE** (CE Marking Directive) & **89/336/CEE** (Directive on electromagnetic compatibility). Directive **2000/14/ECC** (Annex V).

DE CE Konformitätserklärung

Der Unterzeichnete, bevollmächtigt durch E.O.P.I., erklärt, daß die Kettensägen mit Benzinmotor **MS55, MS60**, hergestellt durch E.O.P.I., 23868 Valmadrera (LC), Via Como 72, Italy, den Europäischen Richtlinien **98/37/CEE** (Maschinenrichtlinie), **73/23/EEC** (Niederspannungsrichtlinie), **93/68/CEE** (CE Kennzeichnungsrichtlinie) & **89/336/CEE** (EMV Richtlinie) entspricht. Richtlinie **2000/14/ECC** (Anhang V).

FR Déclaration de conformité Européenne

Le soussigné, dûment mandaté par E.O.P.I., déclare que les tronçonneuses thermiques **MS55, MS60**, fabriqué par E.O.P.I., 23868 Valmadrera (LC), Via Como 72, Italy, est conforme aux Directives Européennes **98/37/CEE** (Directive Sécurité Machine), **73/23/EEC** (Directive Basse Tension), **93/68/CEE** (Directive Marquage CE) & **89/336/CEE** (Directive EMC). Directive **2000/14/ECC** (Annexe V).

NL EG Conformiteitsverklaring

Ondergetekende, gemachtigd door E.O.P.I., verklaart dat de benzine aangedreven kettingzaag **MS55, MS60**, geproduceerd door E.O.P.I., 23868 Valmadrera (LC), Via Como 72, Italy voldoet aan de Europese Richtlijnen **98/37/CEE** (Machinerie Richtlijn), **73/23/EEC** (Mataala jännite-direktiivi), **93/68/CEE** (EG Markering Richtlijn) & **89/336/CEE** (Richtlijn aangaande elektromagnetische compatibiliteit). Richtlijn **2000/14/ECC** (Annex V).

NO EF Erklæring om Overensstemmelse

Undertegnede, autorisert av E.O.P.I., erklærer at bensindrevne kjedesager **MS55, MS60**, produsert av E.O.P.I., 23868 Valmadrera (LC), Via Como 72, Italy, er i overensstemmelse med følgende europeiske direktiver: **98/37/CEE** (Maskindirektiv), **73/23/EEC** (Direktiv for lavspenning), **93/68/CEE** (CE-mærkningsdirektiv) & **89/336/CEE** (Direktiv om elektromagnetisk kompatibilitet). Direktiv **2000/14/ECC** (Annex V).

FI EU Julistus Vastaavuudesta

Allekirjoittanut, E.O.P.I. in valtuuttamana, vakuuttaa että bensiinimootorisahat **MS55, MS60**, ja jotka on valmistanut E.O.P.I., 23868 Valmadrera (LC), Via Como 72, Italy, on Euroopan direktiivien **98/37/CEE** (Koneisto-direktiivi), **73/23/EEC** (Matala jännite-direktiivi), **93/68/CEE** (CE Merkintä-direktiivi) & **89/336/CEE** (Elektromagneettinen Yhteensopivuus-direktiivi) mukainen. Direktiivi **2000/14/ECC** (Lite V).

SE EC Declaration of Conformity

Underteknad, auktoriserad av E.O.P.I., försäkrar att bensindrivna kedjesågar **MS55, MS60**, tillverkade av E.O.P.I., 23868 Valmadrera (LC), Via Como 72, Italy, är i överensstämmelse med följande europeiska direktiv **98/37/CEE** (Maskindirektiv), **73/23/EEC** (Lågspanningsdirektiv), **93/68/CEE** (CE-märknings-direktiv) & **89/336/CEE** (Elektromagnetisk kompatibilitet). Direktiv **2000/14/ECC** (Annex V).

DK EU Overensstemmelse-erklæring

Undertegnede, bemyndiget af E.O.P.I., erklærer herved, at benzindrevne kædesave **MS55, MS60**, E.O.P.I., 23868 Valmadrera (LC), Via Como 72, Italy, er i overensstemmelse med de europæiske direktiver **98/37/CEE** (Maskineri direktiv), **73/23/EEC** (Direktiv for lavspænding), **93/68/CEE** (CE mærkningsdirektiv) & **89/336/CEE** (EMC-direktiv). Direktiv **2000/14/ECC** (Annex V).

ES Declaracion de cumplimiento de la directriz de la UE

El abajo firmante, autorizado por E.O.P.I., afirma que las motosierras de gasolina **MS55, MS60**, fabricado por E.O.P.I., 23868 Valmadrera (LC), Via Como 72, Italy, cumple con las directivas Europeas **98/37/CEE** (Directiva sobre Maquinaria), **73/23/EEC** (Directiva sobre Bajo Voltaje), **93/68/CEE** (Directiva sobre Marcas de la CE) & **89/336/CEE** (Directiva sobre 'Compatibilidad Electro Magnetica'). Directiva **2000/14/ECC** (Anexo V).

PT Declaração de Conformidade CE

O abaixo assinado, autorizado por E.O.P.I., declara que as serras mecânicas a gasolina **MS55, MS60**, fabricada por E.O.P.I., 23868 Valmadrera (LC), Via Como 72, Italy, estão de acordo com as Directivas Europeas **98/37/CEE** (Directiva de Maquinaria), **73/23/EEC** (Directiva sobre Baixas Tensões), **93/68/CEE** (Directiva de Marcação CE) e **89/336/CEE** (Directiva de Compatibilidade Electromagnética). Directiva **2000/14/ECC** (Apêndice V).

IT Dichiarazione di Conformità CE

Il sottoscritto, autorizzato dalla E.O.P.I., dichiara che la sega a catena portatile da legno **MS55, MS60**, costruito dalla E.O.P.I., 23868 Valmadrera (LC), Via Como 72, Italia, è conforme alle Direttive Europee: **98/37/CEE** (Direttiva Macchine), **73/23/EEC** (Direttiva Bassa Tensione), **93/68/CEE** (Direttiva Marcatura CEE) & **89/336/CEE** (Direttiva Compatibilità Elettromagnetica). Direttiva **2000/14/ECC** (Allegato V).

GR Δήλωση Συμμόρφωσης προς τις Εντολές της ΕΕ

Ο υπογεγραμμένος, με εξουσιοδότηση της Ε.Ο.Π.Ι., δηλώνω ότι: τα βενζινοκίνητα αλυσοπίσθια **MS55, MS60**, κατασκευασθέντα από την Ε.Ο.Π.Ι., 23868 Valmadrera (LC), Via Como 72, Italy, ανταποκρίνονται προς τις Ευρωπαϊκές Εντολές, **73/23/CEE** Οδηγία χυμλής τάσης (ασφάλεια), **98/37/CEE** (η περί Μηχανημάτων Εντολή), **93/68/CEE** (η περί του Σήματος CE Εντολή) & **89/336/CEE** (η περί Ηλεκτρομαγνητικής Συμβατότητας Εντολή). Κανονισμού **2000/14/ECC** (V).

HU EC nyilatkozat

Alulírott, a E.O.P.I. által meghatalmazott ezennek kijelenti, hogy a benzinmotoros láncfűrész **MS55, MS60**, amelyet a E.O.P.I., 23868 Valmadrera (LC), Via Como 72, Italy gyárt, megfelelnek a **98/37/CEE** európai irányelvnek (gépi berendezések irányelve), a **73/23/ EEC**, a **93/68/CEE** európai irányelvnek (CE-irányelv) és a **89/336/CEE** (az elektromágneses kompatibilitásra vonatkozó irányelv). Direktíva **2000/14/ECC** (Melléklet V).

Electrolux Outdoor Products

Via Como 72

23868 Valmadrera (Lecco)

ITALIA

Phone +39 0341 203111 - Fax +39 0341 581671



Valmadrera, 15.12.01
Pino Toderò (Direttore Tecnico)
E.O.P.I.

Our policy of continuous improvement means that the specification of products may be altered from time to time without prior notice. Electrolux Outdoor Products manufacture products for a number of well known brands under various registered patents, designs and trademarks in several countries.

© Electrolux Outdoor Products

**The Electrolux Group. The world's No. 1 choice.**

The Electrolux Group is the world's largest producer of powered appliances for kitchen, cleaning and outdoor use. More than 55 million Electrolux Group products (such as refrigerators, cookers, washing machines, vacuum cleaners, chain saws and lawn mowers) are sold each year to a value of approx. USD 14 billion in more than 150 countries around the world.



Free Manuals Download Website

<http://myh66.com>

<http://usermanuals.us>

<http://www.somanuals.com>

<http://www.4manuals.cc>

<http://www.manual-lib.com>

<http://www.404manual.com>

<http://www.luxmanual.com>

<http://aubethermostatmanual.com>

Golf course search by state

<http://golfingnear.com>

Email search by domain

<http://emailbydomain.com>

Auto manuals search

<http://auto.somanuals.com>

TV manuals search

<http://tv.somanuals.com>