



USER MANUAL

Rotary Lawn Mower

SAFETY OPERATION MAINTENANCE



Your lawn mower has been engineered and manufactured to our high standard for dependability, ease of operation, and operator safety.



WARNING: To reduce the risk of injury, the user must read and understand the operator's manual before using this product.

Thank you for your purchase.

SAVE THIS MANUAL FOR FUTURE REFERENCE

Model No. M48A



AU

LAWN MOWER WARRANTY

The benefits conferred by this warranty are in addition to all other conditions and warranties in respect of this product which the consumer may have taken under the Competition and Consumer Act 2010 or by any legislation of a State or Territory of Australia. This product is warranted by Husqvarna Australia Pty Ltd (ABN 45 115 475 619) (the "Company") to be free from defects in material and workmanship for a period of 24 months from the date of original purchase. The Company during the period of the warranty, will at its option, and subject to the conditions stated herein, repair or replace without charge this product or any component part, which upon examination by an Authorised Service Agent or by the Company is found to be defective.

Warranty conditions:

This warranty will not apply:

- (i) where this product has been subjected to misuse, abuse, accident or want of care;
- (ii) where this product has been used for a purpose for which it was not designed or is not suited;
- (iii) where the service of this product has been undertaken by a person not authorised by the Company to carry out such work or where parts that have not been approved by the Company have been used;
- (iv) where this product has been used for industrial purposes.

Should service become necessary during the warranty period, the purchaser should contact an Authorised Service Agent or the Company. In order to obtain warranty service, the purchaser must present the store receipt showing the name of the retailer and the date of purchase together with a completed Warranty Card. The period of the warranty begins from the original date of purchase, notwithstanding any subsequent repair or parts replacement. No additional warranty or guarantee other than set out in this document, whether written or verbal, is authorised to be made on the Company's behalf. The purchaser shall be responsible for delivery or causing the product to be delivered to the Company or the Authorised Service Agent and the purchaser shall be responsible for all charges in connection with re-delivery of the product and/or the delivery of parts. Damage in transit is not covered by this warranty and purchasers should remove from the product any liquids (if applicable) before sending and pack the product securely to prevent damage.

WARRANTY EXCLUSIONS

Normal wear parts or components are subject to separate terms as follows: Normal wear parts, components or service required when performing normal and regular maintenance of this product are not covered by warranty unless it is found to be defective by an Authorised Service Agent or by the Company. Normal wear parts include, but are not limited to:

Worn Blades.

Lubricants.

Spark Plugs

Engine Tune-ups.

Carburetor Tune-ups.

Filters.

Returns based on the above listed normal wear parts will not be accepted under this warranty as they are considered consumable items and are at the expense of the purchaser.

WARNING

Discharge openings must be guarded at all times. Do not hold the safety flap while moving.

- 1 Inspect the area where the equipment is to be used and remove all stones, sticks, wire, bones and other foreign, hard objects before mowing; they could be thrown by the blade.
- 2 Never mow while barefoot or wearing open toe sandals or thongs. Wear long trousers and heavy-duty shoes. It is advisable to wear suitable eye and hearing protection.
- 3 Read the Owner's Manual carefully and know the controls. Learn how to stop the engine quickly in an emergency.
- 4 Stop the engine and disconnect the spark plug lead before attempting to clear blockages, checking or working on the mower.
- 5 Never attempt to adjust cutting height with the engine running.
- 6 Never operate the equipment in wet grass, always be sure of your footings, keep a firm grip on the handles and walk, never run and never walk backwards while cutting grass.
- 7 Check all nuts, bolts and screws before starting. Always be sure your mower is in a safe operating condition. Use only replacement parts made or guaranteed by Husqvarna.
- 8 Refuel outdoors only. Do not smoke while refueling engine. Add fuel before starting the engine. Never remove fuel cap with engine running or add petrol while the engine is running. If petrol is spilt, do not attempt to start the engine. Clean all spilt fuel and move the mower away from the spilled area. Avoid creating any source of ignition until petrol vapours have dissipated.
- 9 Replace worn or damaged blades, as worn blades and worn bolts are major hazards.
- 10 Mow only in good daylight.
- 11 Do not operate the engine in a confined space where exhaust fumes can collect, as they can be lethal.
- 12 Do not put hands or feet near or under rotating parts. Always keep clear of the blades and discharge opening.
- 13 Stop the engine whenever you leave the mower even for a moment, before cleaning and when making any adjustments or inspections.
- 14 Mow across the face of slope, never up and down. Exercise extreme caution when changing direction on slopes. Do not mow excessively steep slopes.
- 15 Stop the engine when crossing gravel driveways, walks or roads.
- 16 Start the engine carefully with feet well away from the blades.
- 17 Store fuel in a cool place in an approved container specifically designed for the purpose. In general, plastic containers are unsuitable.
- 18 Stop the engine and disconnect the spark plug lead before inspecting the mower if:
 - (a) the mower begins to vibrate abnormally, or
 - (b) after striking a foreign object.
- 19 Check the catcher for wear and tear, and replace any worn or broken parts.
- 20 To reduce fire hazard, keep engine free of grass, leaves and any spilt fuel.
- 21 Shut the engine off and wait until the blades come to a complete stop before removing the catcher or un-clogging the chute.
- 22 Never pick up or carry a mower when it is operating.
- 23 Replace worn or faulty muffler.
- 24 Before using, always visually inspect to see that blades, blade bolts and cutter assemblies are not worn or damaged. Replace worn or damaged blades and bolts in sets to preserve balance.
- 25 Do not mow whilst people, especially children, or pets are in the mowing area.
- 26 Do not allow children or people unfamiliar with these instructions to use the mower.
- 27 Store the mower in a well-ventilated room away from naked flames such as may be found in hot water heaters.
- 28 Do not over-speed the engine or alter governor settings. Excessive speed is dangerous and shortens mower life.
- 29 Turn the fuel off at the conclusion of mowing and reduce the throttle setting during engine run-out.
- 30 Never cut grass while walking backwards.
- 31 Walk, never run.
- 32 Never use the mower unless the grass catcher, or guards provided, are in position.

TABLE OF CONTENTS

■ General safety Rules	1
■ Introduction	2
■ Specifications	2
■ Description	3
■ Assembly Instructions	4
■ Preparing the Engine	5-6
■ Running the Engine	6-7
■ Starting the Engine	7-8
■ Cutting Height Control	8
■ Blade Maintenance	10
■ Maintenance	11-13
■ Mowing tips	14

GENERAL SAFETY RULES

The purpose of safety rules is to attract your attention to possible dangers. The safety symbols and the explanations with them, require your careful attention and understanding. The safety warning by themselves do not eliminate any danger. The instruction or warnings they give are not substitutes for proper accident prevention measures.



SAFETY ALERT SYMBOL

Indicates caution or warning. May be used in conjunction with other symbols or pictures.

Failure to obey a safety warning can result in serious injury to yourself or to others. Always follow the safety precautions to reduce the risk of fire, electric shock and personal injury.

Do not attempt to operate this tool until you have read thoroughly and completely understood the

safety rules, etc. contained in this manual. Failure to comply can result in accidents involving fire, electric shock or serious personal injury. Save this User Manual and review it frequently for continual safe operation and for instructing others who may use this tool.



The operation of any tool can result in foreign objects being thrown into your eyes, which can result in severe eye damage.

Before beginning power tool operation, always wear safety goggles or safety glasses with side shields and a full face shield when needed. We recommend Wide Vision Safety Mask for use over eye glasses or standard safety glasses with side shields.

INTRODUCTION

Your new lawnmower has been engineered and manufactured to McCulloch's high standard of dependability, ease of operation, and operator safety. Properly cared for, it will give you years of rugged, trouble free performance. If you use your lawnmower properly and only for what it is intended, you will enjoy years of safe, reliable service

Keep this manual safe for future reference.

Important: Servicing of a tool with double Insulation requires extreme care and knowledge of the system and should be performed only by a qualified service technician. For service we suggest you return the tool to your nearest McCulloch Authorised Service Centre for repair. When servicing, use only identical McCulloch's replacement parts.



WARNING

Carefully read through this entire owner's manual. Pay close attention to the general safety rules and rules for safe operation, before using your new unit.

SPECIFICATIONS

MODEL NO	M48A
Engine Speed	3000 r.p.m
Fuel Tank Capacity	900ml
Oil Tank Capacity	500ml
Air Cleaner Element	Paper Cartridge
Air Cleaner Location	Handle Bar
Cutting Width	480cm (19")
Blades	4 Swing Back
Height Adjustment	12 Position Single Lever
Cutting Heights	15mm to 55mm
Wheel Size (F/Rmm)	200/200mm
Bearing Type	Dual Metal Ball Bearing
Tread	Rubber
Grass Catcher	Solid Plastic
Under Deck Wash Port	Yes
Weight (Incl. Catcher)	45.7kg

DESCRIPTION

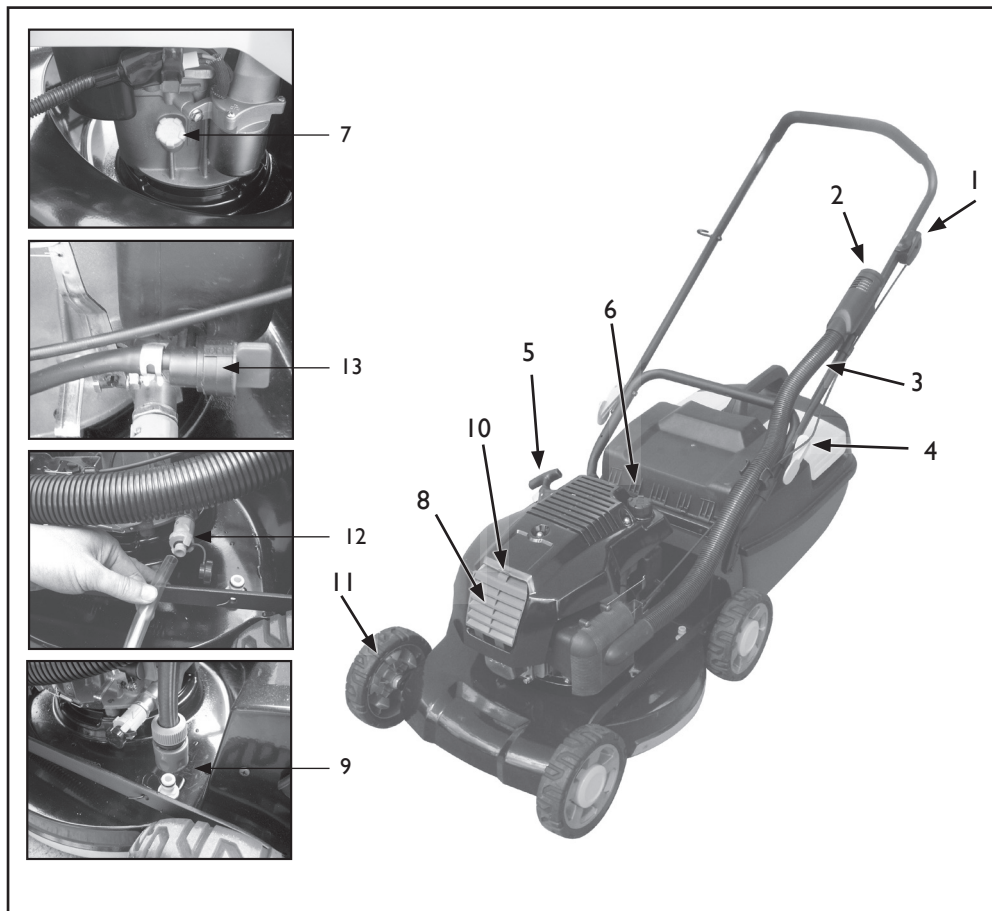

- | | |
|--|--|
| 1. Dash Panel for Key Start and Engine Control Lever | 6. Fuel Filler Cap |
| 2. High Intake Air Cleaner | 7. Oil Filler Cap |
| 3. Air Tube | 8. Muffler Housing |
| 4. Locking Knob | 9. Under Deck Wash Connector |
| 5. Starter Handle | 10. Spark Plug |
| | 11. Cast Aluminium Ball Bearing Wheels |
| | 12. Above Deck Oil change Tap |
| | 13. Fuel Tap |

ASSEMBLY INSTRUCTIONS

Please refer to the following sections when preparing the mower for its first use

GRASS CATCHER

1. Position the two catcher halves as shown in (Figure 1A).

Ensure the catcher door is pushed down firmly onto the catcher to lock in place.

Align the locating lugs marked 1 & 2 at the front of the catcher. With the catcher base on the ground, push the top section on each side of locator lug 1 until it clicks into place. (Figure 1B)

Repeat this process for locator lug 2

2. Continue working from the front and push each locator lug into position from number 1 through 8 until completed. i.e. start with locator lug number 1 then 2, 3, 4, 5, 6, 7, and 8. (Figure 1A)
3. **WARNING: DO NOT HIT THE CATCHER WITH YOUR HAND OR A MALLET.** This will break the plastic. ALWAYS START AT POSITION 1. Do not try to assemble the catcher from any other starting point as this will make it difficult to assemble the clips.
4. Before use, check that all the lugs are completely clipped. Test the assembly by holding the top handle and pushing down on the base of the catcher. (Figure 1C)

I. List of Components:

- A. Lower Catcher
- B. Upper Catcher
- C. Mid Handle Assembly
- D. Upper Handle Assembly

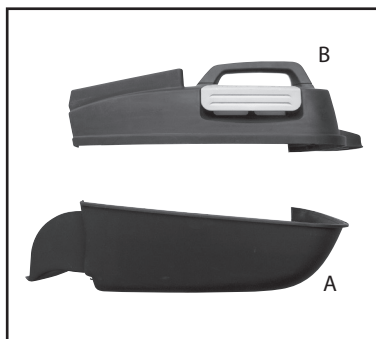

Figure. 1A



Figure. 1B



Figure. 1C

PREPARING THE ENGINE

Please read and understand the engine instructions prior to operating the lawnmower.

OIL - SAE30

CAUTION

DO NOT START your four stroke engine before making sure that it has been filled with the right amount of the correct grade of oil.

Four stroke (cycle) engines are shipped without oil. Place the mower on a level position, unscrew the 'OIL FILL' cap and slowly pour oil provided into the sump. Fill to the full mark on the dipstick. The capacity is approximately 500ml. To check engine oil in. Remove cap and observe oil level on dip stick.

NOTE There may be a small amount of oil in the engine after draining. Fill using dip stick to avoid over filling

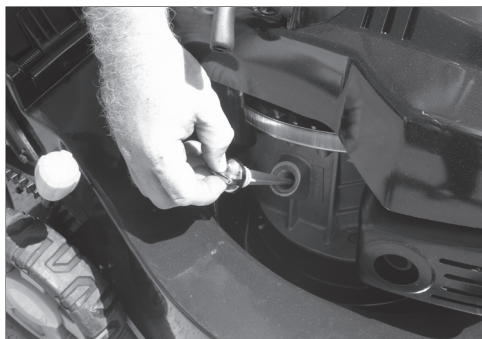

Figure 3

CHANGING THE ENGINE OIL

FOUR STROKE ENGINES should be checked for oil level every 8 hours running (or daily), and the oil should be drained and replaced after every 50 hours of use.

See Engine Lubrication section for oil change information.



Figure 4

PREPARING THE ENGINE

WARNING

Petrol vapour is highly flammable and explosive. Handle with extreme care. Store in an approved container. Do not fill tank when engine is running or is still hot. Do not allow open flame, matches or smoking nearby. Fill tank outdoors in a well-ventilated area. Wipe away any spills and move the mower away from any petrol fumes before starting engine.

CAUTION

When filling the fuel tank, always leave an air space of about 5mm to allow for expansion of fuel

FUEL

USE ONLY CLEAN FRESH PETROL AT ALL TIMES, preferably unleaded, with an octane rating of at least 91. Four stroke (cycle) engines use straight fuel.

FUEL FILLING

1. Position the mower on a level surface in a well-ventilated area.
2. Clean around the fuel tank.

3. Remove the fuel tank cap
4. Place a clean funnel in the fuel filler.
5. Fill the fuel tank with unleaded petrol, allowing room in tank for fuel expansion.
6. Replace the fuel tank cap.
7. Clean up any spilt fuel.

RUNNING THE ENGINE

ENGINE

Regular attention to a few simple items will ensure long and trouble-free service from your mower. Carry out the regular maintenance described in the manual, and check the engine mounting bolts regularly to be sure they are tight.

WARNING

Before making any adjustments to your mower make sure that the engine is turned off and that the blade has STOPPED ROTATING. Always disconnect the spark plug wire and make sure it cannot accidentally contact the spark plug before touching anything under the mower housing.

ENGINE CONTROL

This is mounted at the centre of the handle. It operates the choke, for starting, and allows you to set the governed speed of the engine while cutting or to stop the engine.



RUNNING THE ENGINE

You will not need to change the control setting constantly while mowing because the governor holds the selected speed, even under varying cutting loads. The positions for START, RUN, SLOW and STOP are marked.

STARTING THE ENGINE

Ensure that the engine has been prepared correctly and that the fuel tap is turned ON. We recommend that you check the oil level before every mowing session.



WARNING

Never run the engine indoors or in poorly ventilated areas. Engine exhaust contains carbon monoxide, an odourless and deadly gas. Keep hands, feet, hair and loose clothing away from moving parts.

COLD STARTING

1. Set the engine control to the START position
2. Turn the fuel tap to the "ON" position and wait 60 seconds.

3. MANUAL START

- Stand behind the mower. Hold the top the mower stationary. Grasp the starter rope and pull slowly until resistance is felt, then pull briskly.
4. When engine has warmed up for a short time move the engine control lever to the desired speed position for cutting

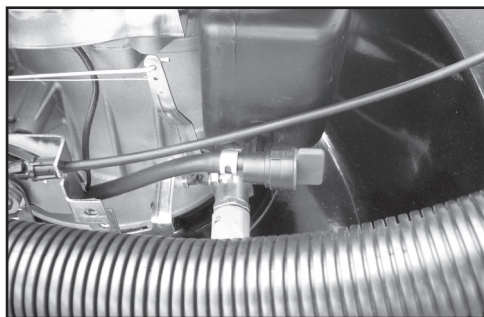

STARTING THE ENGINE

HINTS FOR EASY STARTING

- Stand the mower on a paved drive or path where the blade is clear of the grass. If you must start on the lawn, move to an already cut area and/or raise the cutting height. Do not start the mower on a gravel surface.
- Start a WARM engine with the control in the START position.
- Keep the mower clean underneath

STOPPING

Move the engine control to STOP.

HARD START CHECKLIST

Look for these faults

- | | |
|--|---|
| <p>FUEL</p> <ol style="list-style-type: none"> 1. Insufficient fuel in tank 2. Fuel tap shut off 3. Stale fuel 4. Water or dirt in fuel 5. Blocked air vent in fuel tank cap | <p>IGNITION</p> <ol style="list-style-type: none"> 1. Loose spark plug wire 2. Dirty spark plug electrodes 3. Incorrect spark plug gap 4. Incorrect spark plug type <p>OTHER</p> <ol style="list-style-type: none"> 1. choked air filter (dirt or oil) 2. Incorrect adjustment of engine control cable 3. Cutting blade obstructed |
|--|---|

CUTTING HEIGHT CONTROL LEVER

Turn mower off before adjusting cutting height. The single point cut height control adjusts all four wheels simultaneously. To operate, steady the mower by grasping the handle with one hand, pull the lever outwards from the mower with the other hand, and move it to the desired setting.

For heavy or very long grass it is recommended setting the mower cut height to #4 or more to avoid the possibility of clogging. If clogging becomes persistent because of unfavourable conditions, try walking slower, cutting a narrower strip or raising the cutting height further.



FITTING THE MULCHING PLUG TO THE MOWER (OPTIONAL)

1. Stop the engine.
2. Make sure the discharge chute and the underside of the mower are clean. If not, clean the mower.
3. Raise the flap with left hand, and using the hand-hold on the mulching plug, insert the mulching plug, with the angled section to the mowers right, into the discharge chute. Make sure the back of the plug is sitting on the rear axle, then lower the flap.



Fig. 8A



Fig. 8B

BLADES

Check the blade mounting bolts at frequent intervals for proper tightness.

To check blades, fold top handle down and tilt mower backward and view blades under deck from the front. (see pic) do not place mower on its side! Check the blade condition frequently, particularly if the mower has hit a foreign object or is vibrating. Sub-standard cutting and catching will result from a neglected blade. Your Authorised Dealer can replace blades as necessary, or if you prefer, supply the parts for you to do yourself.



CAUTION

Always use genuine original equipment parts to ensure safety and proper performance. Substitute parts can be disappointing and dangerous.

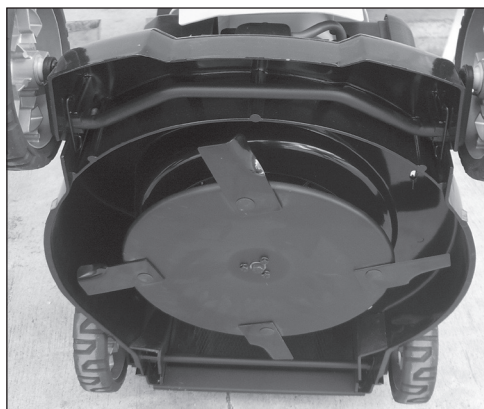

BLADE CHANGE

1. Disconnect the spark plug wire.
2. Adjust the mower to the high cut position.
3. Lift the rear flap and prop open to give full access to the blades.
4. Remove the blades, blade retaining bolts, nuts and washers and discard.
5. Fit the new blades, blade bolts, washers and nuts in set sequence, refer drawing below (to loosen rotate anti-clockwise, to tighten rotate clockwise).

Blade bolt torque : 14.8-22.0 ft-lb (20-30 N•m)

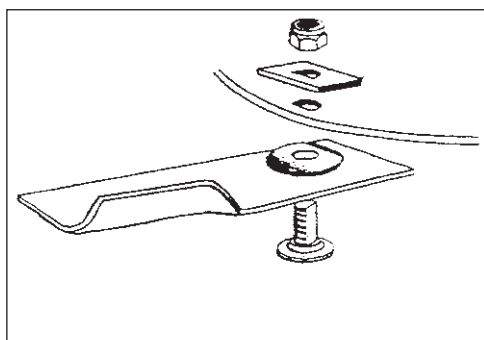

MAINTENANCE



CAUTION

Never tip mower sideways. To gain access to blades or cutting disc tilt backwards so spark plug is up.



CAUTION

Failure to properly service your mower will reduce its operating performance and could void warranty. Service costs are not covered by warranty.

ENGINE LUBRICATION

Check engine oil before every mowing session or every 8 hours or daily.

ENGINE MAINTENANCE SCHEDULE

First 5 Hours

Change engine oil - Oil SAE30. 500ml.

Every 25 Hours or Every Season Change engine oil if operated under heavy load or in high ambient temperature above 35 C. SAE30. 500ml.

Every 50 Hours or Every Season Change engine oil. Use 500 ml of SAE30 oil.

Clean mower.

Mower service should be carried out by an authorised McCulloch service agent.

STORAGE

If mower is to be stored for over 60 days, you will need to drain the fuel, if full, to prevent gum from forming in fuel system or on essential carburettor parts.

Remove spark plug and pour about 10ml of engine oil into cylinder; replace spark plug and turn engine over (pull cord slowly).

SPARK PLUG

Use only genuine replacement spark plug type 5223761-01. For best results, replace the spark plug every 100 hours of use.

1. Stop the engine and remove the spark plug wire.
2. Remove spark plug
3. Screw the replacement spark plug into the engine and tighten to 25-30 N•m torque and replace spark plug wire.
4. Spark plug gap. 0.6 — 0.7mm



CAUTION

Do not over-tighten the spark plug as engine damage may occur

DECK CLEANING

Wipe deck with a damp cloth.



CAUTION

Do not hose engine. Water can damage engine or contaminate the fuel system

MAINTENANCE

ABOVE DECK OIL CHANGE

1. Place 12mm (inside diameter) tube onto outlet of above deck oil change tap. Fig. 11A
2. Push and turn tap to allow oil to flow. Fig. 11B
3. Ensure oil is drained into a suitable container for proper disposal.

Note To ensure full drainage of oil sump it may be necessary to prop up the wheels on the opposite side of mower so that the engine is tilted towards the outlet.

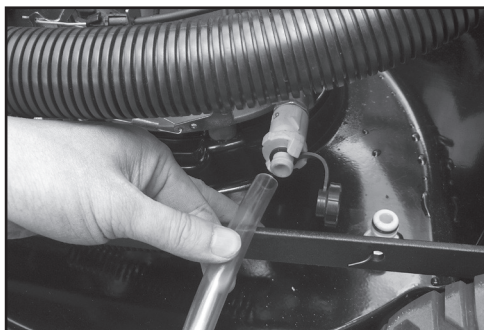

Fig. 11A

UNDER DECK WASH CONNECTOR

1. Attach click on hose fitting to the connector. (Fig. 11C)
2. Start mower and set engine speed control to FAST.
3. Turn hose on.
4. Allow approximately ONE MINUTE to clean the underside of the deck.
5. Turn off hose and stop engine.
6. Disconnect hose from mower.
7. Allow mower to dry before storage.

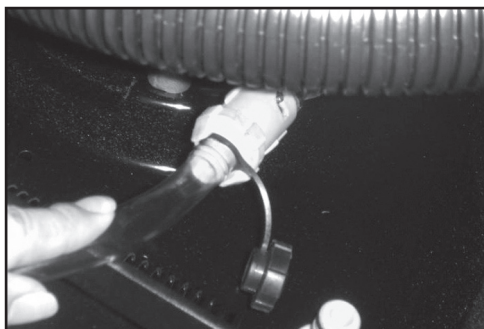

Fig. 11B



Fig. 11C

MAINTENANCE



CAUTION

Do not allow dirt or dust to clog the air filter element.

ENGINE AIR CLEANER

The engine air cleaner element must be serviced (cleaned) after 25 hours normal mowing.

TO REPLACE HIGH INTAKE PAPER AIR FILTER

1. To access filter element push down air snorkel release clip pull air snorkel away from air filter box. (Fig. 12A)
2. Remove old air filter element and replace with new. (Fig. 12B)
3. Insert new filter into housing so that the end with the opening fits into the inner tube in the housing.
4. Replace air snorkel and clip into place.



Fig. 12A



Fig. 12B

MOWING TIPS

- The best time to mow your lawn is the late afternoon. By this time the grass has had a chance to dry out. Also the sensitive newly cut grass area isn't exposed to the direct sun.
- For healthy growth, grass should not be cut too short. Using the lowest settings can result in destruction of the crown of grass, allowing flat lying weeds to develop.
- Vary your cutting pattern from week to week. One week mow your lawn from north to south, the next week, mow your lawn from east to west. This will help prevent matting and graining of the grass.
- For best performance, always keep the mower blade sharp. A blunt blade tends to tear, not cut, the blades of grass.
- When cutting very long grass, a preliminary cut on a high setting, followed by a lower cut (preferably a day or so later), will minimise the overall time required for the job.
- Do not try to cut too much off the grass at one time. This can cause excessive loads to be put on the engine and also affect the mulching performance.
- Clean the mowing chamber frequently to remove grass build-up. This will keep mowing performance at its best, especially when mulching. Avoid cutting your lawn when it is wet. Wet grass tends to form clumps and interferes with the mulching action of the mower.
- If you are not collecting the cut grass, mow in a pattern that deposits the clippings on the previously cut path. So, if your mower discharges clippings on the left, the next cut should be to the right of the previous one, and vice-versa.
- When cutting close to obstructions such as tree trunks, and when mowing to the edge of a lawn where there is no wheel support, use the left side of the mower, giving a useful blade 'overhang' for ready access to awkward areas.

Free Manuals Download Website

<http://myh66.com>

<http://usermanuals.us>

<http://www.somanuals.com>

<http://www.4manuals.cc>

<http://www.manual-lib.com>

<http://www.404manual.com>

<http://www.luxmanual.com>

<http://aubethermostatmanual.com>

Golf course search by state

<http://golfingnear.com>

Email search by domain

<http://emailbydomain.com>

Auto manuals search

<http://auto.somanuals.com>

TV manuals search

<http://tv.somanuals.com>