

OPERATOR'S MANUAL

ROUTER

WITH FIXED AND PLUNGE BASES

DOUBLE INSULATED

R2900

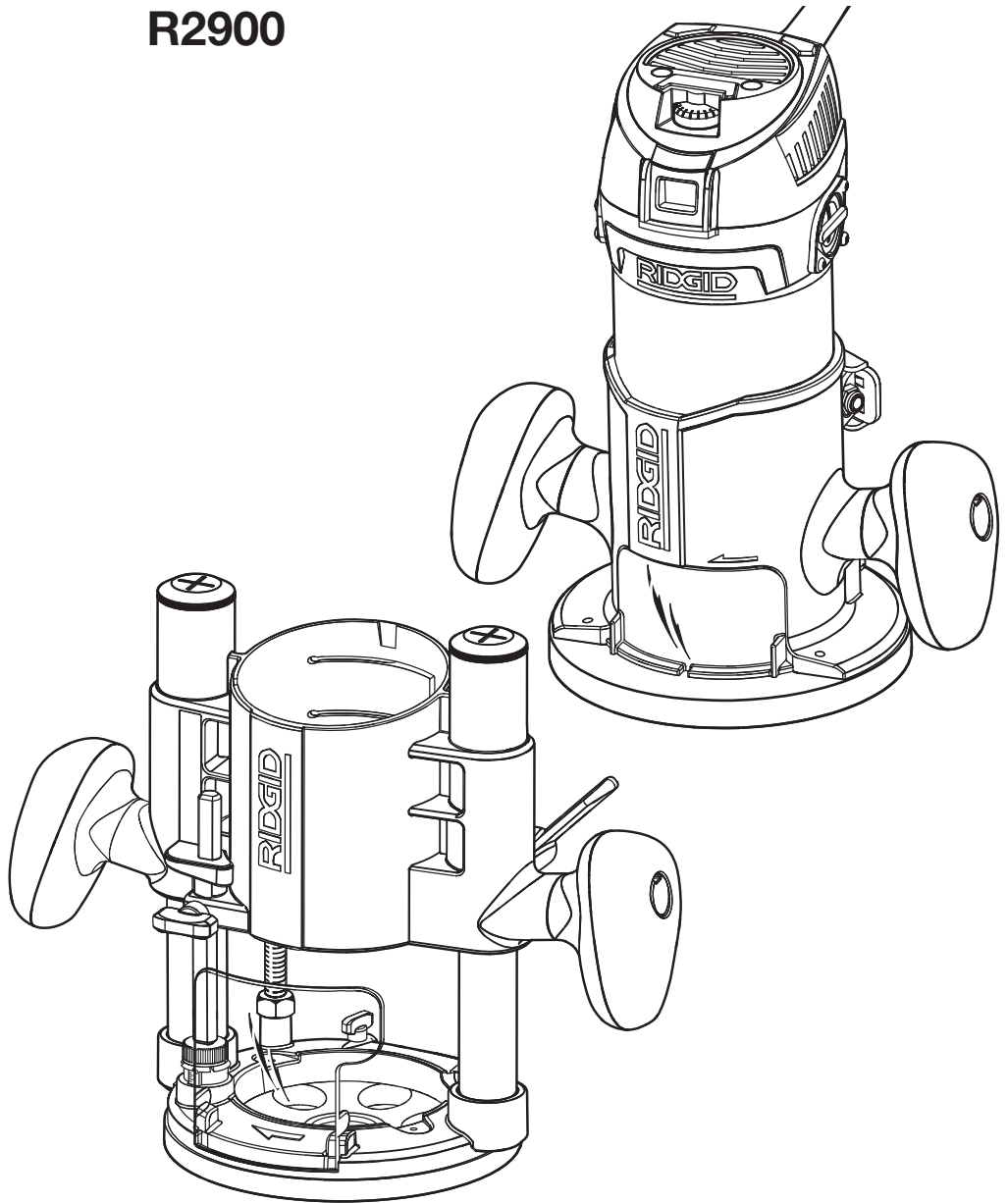

Your router has been engineered and manufactured to our high standard for dependability, ease of operation, and operator safety. When properly cared for, it will give you years of rugged, trouble-free performance.

⚠ WARNING:

To reduce the risk of injury, the user must read and understand the operator's manual before using this product.

Thank you for buying a RIDGID product.

SAVE THIS MANUAL FOR FUTURE REFERENCE

TABLE OF CONTENTS

■ Introduction	2
■ General Safety Rules	3-4
■ Specific Safety Rules.....	4
■ Symbols.....	5-6
■ Electrical	7
■ Features.....	8-9
■ Assembly	9
■ Operation.....	10-20
■ Adjustments.....	20-21
■ Maintenance	22
■ Accessories	22
■ Warranty	23
■ Customer Service Information.....	24

INTRODUCTION

This tool has many features for making its use more pleasant and enjoyable. Safety, performance, and dependability have been given top priority in the design of this product making it easy to maintain and operate.

GENERAL SAFETY RULES

WARNING:

Read all instructions. Failure to follow all instructions listed below may result in electric shock, fire and/or serious injury. The term “power tool” in all of the warnings listed below refers to your mains-operated (corded) power tool or battery-operated (cordless) power tool.

SAVE THESE INSTRUCTIONS

WORK AREA SAFETY

- **Keep work area clean and well lit.** Cluttered or dark areas invite accidents.
- **Do not operate power tools in explosive atmospheres, such as in the presence of flammable liquids, gases or dust.** Power tools create sparks which may ignite the dust or fumes.
- **Keep children and bystanders away while operating a power tool.** Distractions can cause you to lose control.

ELECTRICAL SAFETY

- **Power tool plugs must match the outlet. Never modify the plug in any way. Do not use any adaptor plugs with earthed (grounded) power tools.** Unmodified plugs and matching outlets will reduce risk of electric shock.
- **Avoid body contact with earthed or grounded surfaces such as pipes, radiators, ranges and refrigerators.** There is an increased risk of electric shock if your body is earthed or grounded.
- **Do not expose power tools to rain or wet conditions.** Water entering a power tool will increase the risk of electric shock.
- **Do not abuse the cord. Never use the cord for carrying, pulling or unplugging the power tool. Keep cord away from heat, oil, sharp edges or moving parts. Damaged or entangled cords increase the risk of electric shock.**
- **When operating a power tool outdoors, use an extension cord suitable for outdoor use. Use of a cord suitable for outdoor use reduces the risk of electric shock.**

PERSONAL SAFETY

- **Stay alert, watch what you are doing and use common sense when operating a power tool. Do not use a power tool while you are tired or under the influence of drugs, alcohol or medication.** A moment of inattention while operating power tools may result in serious personal injury.
- **Use safety equipment. Always wear eye protection.** Safety equipment such as dust mask, non-skid safety shoes, hard hat, or hearing protection used for appropriate conditions will reduce personal injuries.
- **Avoid accidental starting. Ensure the switch is in the off-position before plugging in.** Carrying power tools

with your finger on the switch or plugging in power tools that have the switch on invites accidents.

- **Remove any adjusting key or wrench before turning the power tool on.** A wrench or a key left attached to a rotating part of the power tool may result in personal injury.
- **Do not overreach. Keep proper footing and balance at all times.** This enables better control of the power tool in unexpected situations.
- **Dress properly. Do not wear loose clothing or jewelry. Keep your hair, clothing and gloves away from moving parts.** Loose clothes, jewelry, or long hair can be caught in moving parts.
- **If devices are provided for the connection of dust extraction and collection facilities, ensure these are connected and properly used.** Use of these devices can reduce dust-related hazards.
- **Do not wear loose clothing or jewelry. Contain long hair.** Loose clothes, jewelry, or long hair can be drawn into air vents.
- **Do not use on a ladder or unstable support.** Stable footing on a solid surface enables better control of the power tool in unexpected situations.

POWER TOOL USE AND CARE

- **Do not force the power tool. Use the correct power tool for your application.** The correct power tool will do the job better and safer at the rate for which it was designed.
- **Do not use the power tool if the switch does not turn it on and off.** Any power tool that cannot be controlled with the switch is dangerous and must be repaired.
- **Disconnect the plug from the power source and/or the battery pack from the power tool before making any adjustments, changing accessories, or storing power tools.** Such preventive safety measures reduce the risk of starting the power tool accidentally.
- **Store idle power tools out of the reach of children and do not allow persons unfamiliar with the power tool or these instructions to operate the power tool.** Power tools are dangerous in the hands of untrained users.
- **Maintain power tools. Check for misalignment or binding of moving parts, breakage of parts, and any other condition that may affect the power tool's operation. If damaged, have the power tool repaired before use.** Many accidents are caused by poorly maintained power tools.
- **Keep cutting tools sharp and clean.** Properly maintained cutting tools with sharp cutting edges are less likely to bind and are easier to control.
- **Use the power tool, accessories and tool bits etc., in accordance with these instructions and in the manner intended for the particular type of power tool, taking into account the working conditions and the work to be performed. Use of the power tool for operations different from those intended could result in a hazardous situation.**

GENERAL SAFETY RULES

SERVICE

- **Have your power tool serviced by a qualified repair person using only identical replacement parts.** This will ensure that the safety of the power tool is maintained.

WARNING!

To reduce the risk of injury, user must read instruction manual.

- **When servicing a power tool, use only identical replacement parts. Follow instructions in the maintenance section of this manual.** Use of unauthorized parts or failure to follow Maintenance instructions may create a risk of shock or injury.

SPECIFIC SAFETY RULES

- **Hold tool by insulated gripping surfaces when performing an operation where the cutting tool may contact hidden wiring or its own cord.** Contact with a “live” wire will make exposed metal parts of the cutting tool “live” and shock the operator.
- **Use clamps or another practical way to secure and support the workpiece to a stable platform.** Holding the work by hand or against your body leaves it unstable and may lead to loss of control.
- **Know your power tool. Read operator’s manual carefully. Learn its applications and limitations, as well as the specific potential hazards related to this tool.** Following this rule will reduce the risk of electric shock, fire, or serious injury.
- **Always wear safety glasses. Everyday eyeglasses have only impact-resistant lenses; they are NOT safety glasses.** Following this rule will reduce the risk of serious personal injury.
- **Protect your lungs. Wear a face or dust mask if the operation is dusty.** Following this rule will reduce the risk of serious personal injury.
- **Protect your hearing. Wear hearing protection during extended periods of operation.** Following this rule will reduce the risk of serious personal injury.
- **Inspect tool cords periodically and, if damaged, have repaired at your nearest authorized service center. Constantly stay aware of cord location.** Following this rule will reduce the risk of electric shock or fire.
- **Check damaged parts. Before further use of the tool, a guard or other part that is damaged should be carefully checked to determine that it will operate properly and perform its intended function. Check for alignment of moving parts, binding of moving parts, breakage of parts, mounting, and any other conditions that may affect its operation. A guard or other part that is damaged should be properly repaired or replaced by an authorized service center.** Following this rule will reduce the risk of shock, fire, or serious injury.
- **Make sure your extension cord is in good condition. When using an extension cord, be sure to use one heavy enough to carry the current your product will draw. A wire gauge size (A.W.G.) of at least 14 is recommended for an extension cord 50 feet or less in length. A cord exceeding 50 feet is not recommended. If in doubt, use the next heavier gauge. The smaller the gauge number, the heavier the cord.** An undersized cord will cause a drop in line voltage resulting in loss of power and overheating.
- **Inspect for and remove all nails from lumber before using this tool.** Following this rule will reduce the risk of serious personal injury.
- **Save these instructions.** Refer to them frequently and use them to instruct others who may use this tool. If you loan someone this tool, loan them these instructions also.
- **Bits coast after router has been turned off.**

WARNING:











Some dust created by power sanding, sawing, grinding, drilling, and other construction activities contains chemicals known to cause cancer, birth defects or other reproductive harm. Some examples of these chemicals are:

- lead from lead-based paints,
- crystalline silica from bricks and cement and other masonry products, and
- arsenic and chromium from chemically-treated lumber.

Your risk from these exposures varies, depending on how often you do this type of work. To reduce your exposure to these chemicals: work in a well ventilated area, and work with approved safety equipment, such as those dust masks that are specially designed to filter out microscopic particles.



SYMBOLS

Some of the following symbols may be used on this tool. Please study them and learn their meaning. Proper interpretation of these symbols will allow you to operate the tool better and safer.

SYMBOL	NAME	DESIGNATION/EXPLANATION
V	Volts	Voltage
A	Amperes	Current
Hz	Hertz	Frequency (cycles per second)
W	Watt	Power
min	Minutes	Time
~	Alternating Current	Type of current
≡	Direct Current	Type or a characteristic of current
n_0	No Load Speed	Rotational speed, at no load
	Class II Construction	Double-insulated construction
.../min	Per Minute	Revolutions, strokes, surface speed, orbits etc., per minute
	Wet Conditions Alert	Do not expose to rain or use in damp locations.
	Read The Operator's Manual	To reduce the risk of injury, user must read and understand operator's manual before using this product.
	Eye Protection	Always wear safety goggles or safety glasses with side shields and, as necessary, a full face shield when operating this product.
	Safety Alert	Precautions that involve your safety.
	No Hands Symbol	Failure to keep your hands away from the blade will result in serious personal injury.
	No Hands Symbol	Failure to keep your hands away from the blade will result in serious personal injury.
	No Hands Symbol	Failure to keep your hands away from the blade will result in serious personal injury.
	No Hands Symbol	Failure to keep your hands away from the blade will result in serious personal injury.
	Hot Surface	To reduce the risk of injury or damage, avoid contact with any hot surface.

SYMBOLS

The following signal words and meanings are intended to explain the levels of risk associated with this product.

SYMBOL	SIGNAL	MEANING
	DANGER:	Indicates an imminently hazardous situation, which, if not avoided, will result in death or serious injury.
	WARNING:	Indicates a potentially hazardous situation, which, if not avoided, could result in death or serious injury.
	CAUTION:	Indicates a potentially hazardous situation, which, if not avoided, may result in minor or moderate injury.
	CAUTION:	(Without Safety Alert Symbol) Indicates a situation that may result in property damage.

SERVICE

Servicing requires extreme care and knowledge and should be performed only by a qualified service technician. For service we suggest you return the product to your nearest **AUTHORIZED SERVICE CENTER** for repair. When servicing, use only identical replacement parts.



WARNING:

To avoid serious personal injury, do not attempt to use this product until you read thoroughly and understand completely the operator's manual. If you do not understand the warnings and instructions in the operator's manual, do not use this product. Call RIDGID customer service for assistance.



WARNING:



The operation of any power tool can result in foreign objects being thrown into your eyes, which can result in severe eye damage. Before beginning power tool operation, always wear safety goggles or safety glasses with side shields and, when needed, a full face shield. We recommend Wide Vision Safety Mask for use over eyeglasses or standard safety glasses with side shields. Always use eye protection which is marked to comply with ANSI Z87.1.

SAVE THESE INSTRUCTIONS

ELECTRICAL

DOUBLE INSULATION

Double insulation is a concept in safety in electric power tools, which eliminates the need for the usual three-wire grounded power cord. All exposed metal parts are isolated from the internal metal motor components with protecting insulation. Double insulated tools do not need to be grounded.

WARNING:

The double insulated system is intended to protect the user from shock resulting from a break in the tool's internal wiring. Observe all normal safety precautions to avoid electrical shock.

NOTE: Servicing of a tool with double insulation requires extreme care and knowledge of the system and should be performed only by a qualified service technician. For service, we suggest you return the tool to your nearest authorized service center for repair. Always use original factory replacement parts when servicing.

ELECTRICAL CONNECTION

This tool has a precision-built electric motor. It should be connected to a **power supply that is 120 volts, 60 Hz, AC only (normal household current)**. Do not operate this tool on direct current (DC). A substantial voltage drop will cause a loss of power and the motor will overheat. If the tool does not operate when plugged into an outlet, double-check the power supply.

EXTENSION CORDS

When using a power tool at a considerable distance from a power source, be sure to use an extension cord that has the capacity to handle the current the tool will draw. An undersized cord will cause a drop in line voltage, resulting in overheating and loss of power. Use the chart to determine the minimum wire size required in an extension cord. Only round jacketed cords listed by Underwriter's Laboratories (UL) should be used.

When working outdoors with a tool, use an extension cord that is designed for outside use. This type of cord is designated with "WA" on the cord's jacket.

Before using any extension cord, inspect it for loose or exposed wires and cut or worn insulation.

**Ampere rating (on tool data plate)

Cord Length	Wire Size (A.W.G.)					
	0-2.0	2.1-3.4	3.5-5.0	5.1-7.0	7.1-12.0	12.1-16.0
25'	16	16	16	16	14	14
50'	16	16	16	14	14	12
100'	16	16	14	12	10	—

**Used on 12 gauge - 20 amp circuit.

NOTE: AWG = American Wire Gauge

WARNING:

Keep the extension cord clear of the working area. Position the cord so that it will not get caught on lumber, tools or other obstructions while you are working with a power tool. Failure to do so can result in serious personal injury.

WARNING:

Check extension cords before each use. If damaged replace immediately. Never use tool with a damaged cord since touching the damaged area could cause electrical shock resulting in serious injury.

FEATURES

PRODUCT SPECIFICATIONS

Depth of Cut.....	2 in.	Peak Horsepower.....	2-1/4 HP
Depth of Plunge.....	2-1/2 in.	No Load Speed.....	10,000-23,000/min.
Collet.....	1/4, 1/2 in.	Input.....	120 V, 60 Hz, AC only, 12 Amps

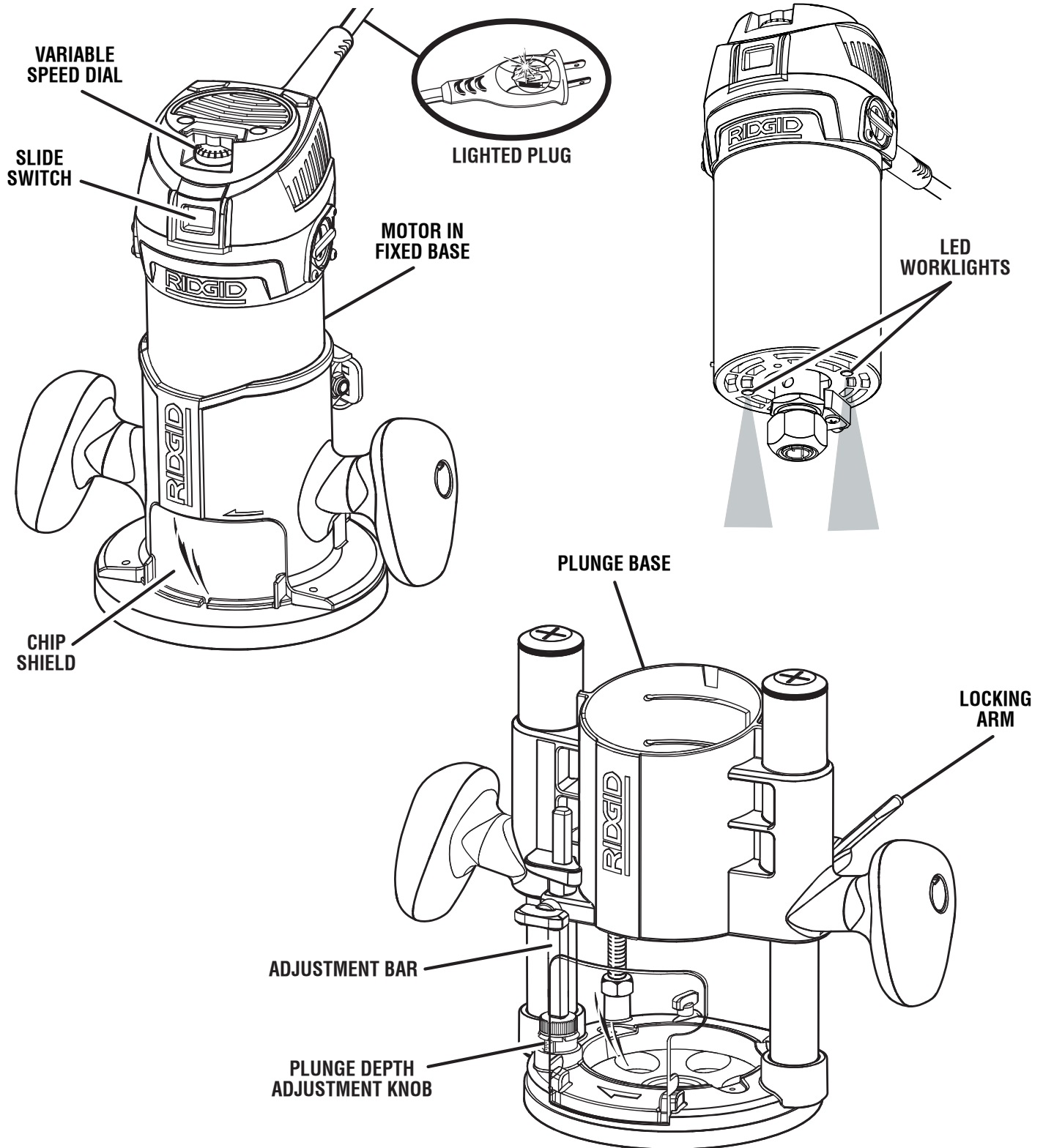

Fig. 1

FEATURES

KNOW YOUR ROUTER

See Figure 1.

Before attempting to use this product, familiarize yourself with all operating features and safety rules.

CENTERING TOOL

The centering tool aligns the subbase with the center of the collet when reattaching the subbase to the router.

CHIP SHIELD

A clear plastic chip shield is installed on the front of the router for protection against flying dust and chips. The shield is designed to fit the opening of the router base.

LED WORKLIGHTS

The LED worklights, located on the bottom of the router motor, illuminate when the slide switch is on. This provides extra light for increased visibility.

LIGHTED PLUG

The lighted plug with tool icon helps to easily identify live tools.

ASSEMBLY

UNPACKING

This product has been shipped completely assembled.

- Carefully remove the tool and any accessories from the box. Make sure that all items listed in the packing list are included.
- Inspect the tool carefully to make sure no breakage or damage occurred during shipping.
- Do not discard the packing material until you have carefully inspected and satisfactorily operated the tool.
- If any parts are damaged or missing, please call 1-866-539-1710 for assistance.

PACKING LIST

Router Motor

Fixed Base

Plunge Base

Router Table Attachment Screws (3)

1/2 in. Collet

1/4 in. Collet

1-1/4 in. Vacuum Adaptors (2)

Vacuum Adaptor Screws (2)

Centering Tool

Collet Wrenches (2)

T-Handle Wrench

Operator's Manual

PLUNGE DEPTH ADJUSTMENT KNOB

The plunge depth adjustment knob, located on the base of the plunge base, provides precise stops for repetitive depth of cut changes. A depth adjustment scale makes quick adjustments to depth of cut changes possible.

SLIDE SWITCH

The slide switch is located on top of the motor housing. It features a soft start to prolong motor life and gives the operator more control when starting the router.

SPINDLE LOCK

The spindle lock keeps the collet from turning while installing and removing bits.

VACUUM ADAPTORS

The vacuum adaptors attach to the router base for dust free routing when used in combination with a vacuum.

VARIABLE SPEED DIAL

The variable speed dial enables speed adjustment of the bit from 10,000/min to 23,000/min.

WARNING:

If any parts are damaged or missing do not operate this tool until the parts are replaced. Failure to heed this warning could result in serious personal injury.

WARNING:

Do not attempt to modify this tool or create accessories not recommended for use with this tool. Any such alteration or modification is misuse and could result in a hazardous condition leading to possible serious personal injury.

WARNING:

Do not connect to power supply until assembly is complete. Failure to comply could result in accidental starting and possible serious personal injury.

OPERATION

⚠ WARNING:

Do not allow familiarity with tools to make you careless. Remember that a careless fraction of a second is sufficient to inflict severe injury.

⚠ WARNING:

Always wear safety goggles or safety glasses with side shields when operating tools. Failure to do so could result in objects being thrown into your eyes resulting in possible serious injury.

⚠ WARNING:

Never attempt to use the router motor without first installing it in one of the approved bases. Failure to heed this warning could result in personal injury and damage to the motor.

CAUTION:

Do not tighten the lock lever without the motor installed in the base. Failure to heed this caution may result in damage to the mechanism.

APPLICATIONS

You may use this tool for the purposes listed below:

- Rout grooves, carve designs, mortise door jambs, and create joints in wood and wood products
- Cabinet making, routing counter tops, and finishing work in wood and wood products

SWITCHING FROM FIXED BASE TO PLUNGE BASE

See Figures 2 - 3.

To remove the fixed base:

- Unplug the router.
- Loosen the lock lever on the fixed base.

NOTE: It should not be possible to move the router motor with the lock lever tightened and the motor correctly installed in either base. If movement is possible with the lock lever tightened in either of the bases, an adjustment to the lock lever needs to be made. See *Adjustments*.

- Hold the router motor with one hand, and with the other, depress and hold the adjustment button.
- Pull the adjustment bar tab from the slot in the motor base.
- Lift the motor up from the slot until the adjustment bar passes out of the slot area.

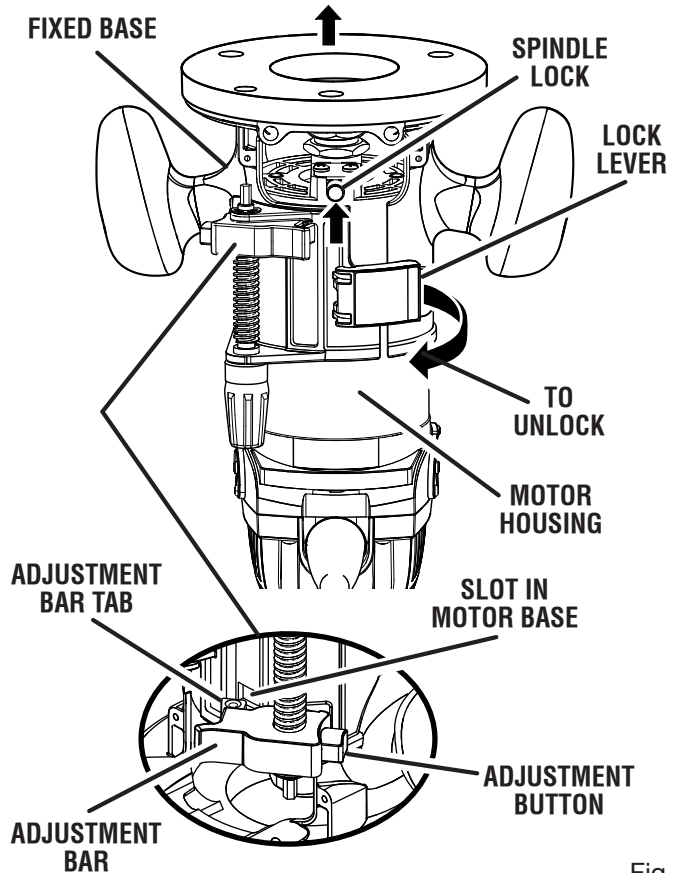

Fig. 2

- After the slot in the motor has cleared the tab, release the adjustment button and press and hold the spindle lock (until it fully locks in the collet spindle) so that it slides behind the fixed base housing.

NOTE: When using the spindle lock for any application, make sure that the button goes all the way in. If the button is depressed and does not go all the way in, turn the collet with the wrenches provided until the spindle lock locks into place.

- Pull the base until it dislodges from the subbase. Use caution, as forcing may result in permanent damage to the locking mechanism.

To install the plunge base:

- Unplug the router.
- Loosen the lock lever.
- Tighten the locking arm for stability.
- Depress and hold the spindle lock until it fully locks in the collet spindle.
- Align the router motor tab with the slot in the plunge base.

OPERATION

- Push the base until it lodges into the motor housing. The spindle lock can be released once the motor slides inside plunge base. It will disengage once it has cleared the inside of the plunge base. Use caution as forcing may result in permanent damage to the locking mechanism.
- Tighten the lock lever.
- Loosen the locking arm if needed.

SWITCHING FROM PLUNGE BASE TO FIXED BASE

See Figures 3 - 4.

To remove the plunge base:

- Unplug the router.
- Loosen the lock lever.
- Tighten the locking arm for stability.
- Depress and hold the spindle lock (until it fully locks in the collet spindle) so that it will slide behind the plunge base housing.
- Pull the base until it dislodges from the motor housing. Use caution, as forcing may result in permanent damage to the locking mechanism. The spindle lock can be released once the motor slides up into the plunge base. It will disengage once it has cleared the inside of the plunge base.

To install the fixed base:

- Unplug the router.
- Loosen the lock lever on the fixed base.
- Depress and hold the spindle lock until it fully locks in the collet spindle.
- Push the base until it lodges into the motor housing. The spindle lock can be released once the motor slides down into the fixed base. It will disengage once it has cleared the inside of the fixed base. Use caution as forcing may result in permanent damage to the locking mechanism.
- Depress and hold the adjustment button.
- Place the adjustment bar tab in the slot on the motor base.
- Tighten the lock lever.

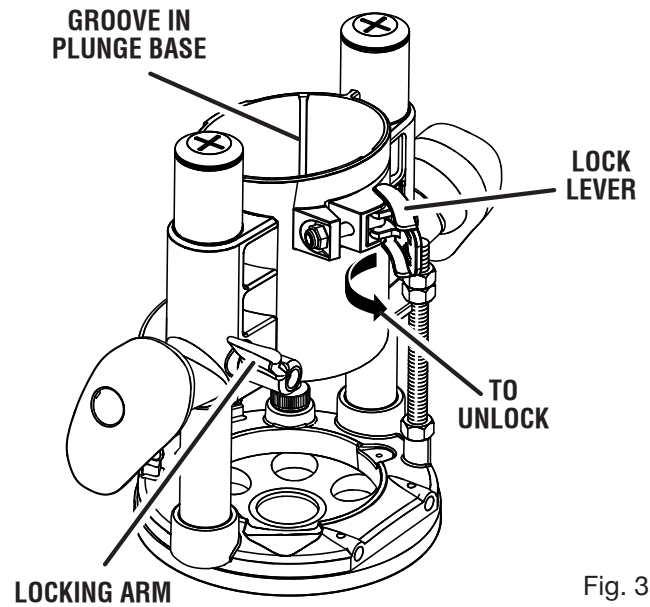

Fig. 3

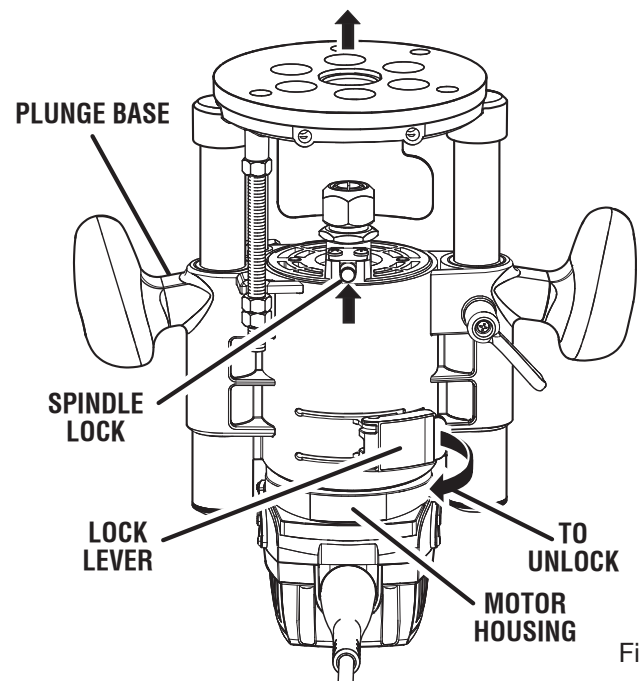

Fig. 4

OPERATION

⚠ WARNING:

If the collet nut is not securely tightened, the bit may detach during use, causing serious personal injury.

⚠ WARNING:

Do not use bits which are larger than 2-1/4 in. Never use bits which are larger in diameter than the opening in the router subbase. These situations could cause possible loss of control or create other hazardous conditions that could cause possible serious personal injury.

⚠ CAUTION:

To prevent damage to the spindle or spindle lock, always allow motor to come to a complete stop before engaging the spindle lock.

⚠ WARNING:

If you are changing a bit immediately after use, be careful not to touch the collet nut, bit, or collet with your hands or fingers. You will get burned because of the heat buildup from cutting. Always use the wrench provided.

INSTALLING/REMOVING COLLETS

The router has two different size collets, a 1/2 in., and a 1/4 in. The 1/4 in. collet should be used with smaller bits for finer work, while the 1/2 in. collet can be used with larger bits that require heavier use.

The collet must be attached to the collet nut before it is put into the shaft.

To remove collet:

- Unplug the router.
- Using the supplied wrench, hold the collet nut with one wrench or depress and hold the spindle lock until it locks into place.
- Loosen the collet nut and remove.
- Release the spindle lock if necessary.

To install collet:

- Unplug the router.
- Using the supplied wrench, hold the collet nut with one wrench or depress and hold the spindle lock until it locks into place.
- Attach collet assembly to collet shaft.
- Tighten the collet nut securely by turning it clockwise with the wrenches provided.
- Release the spindle lock if necessary.

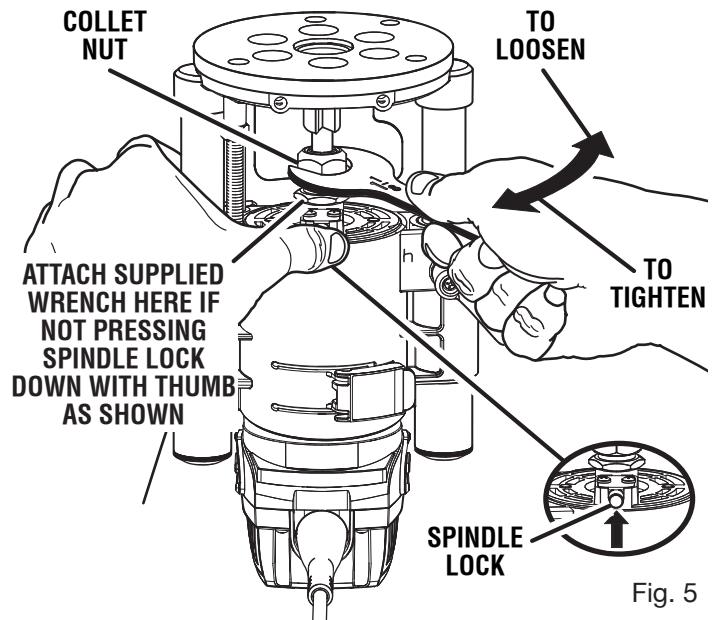

INSTALLING/REMOVING BITS

See Figure 5.

- Unplug the router.

⚠ WARNING:

Before performing any adjustment, make sure the tool is unplugged from the power supply and the switch is in the **OFF** position. Failure to heed this warning could result in serious personal injury.

To install the bit:

- Using the supplied wrench, hold the collet nut with one wrench or depress and hold the spindle lock until it locks into place.
- Loosen the collet nut and remove the bit.
- Insert the bit until the it is approximately 1/8 in. to 1/4 in. away from the collet nut face.
NOTE: Make sure that the collet always clamps the shank (non-cutting end) of the bit.
- Tighten the collet nut securely by turning it clockwise with the wrenches provided.
- Release the spindle lock if necessary.

⚠ WARNING:

Bit continues to rotate after the router has been turned off. To avoid injury, wait until the bit has come to a complete stop before removing router from the workpiece.

OPERATION

To remove the bit:

- Using the supplied wrench, hold the collet nut with one wrench or depress and hold the spindle lock until it locks into place.
- Loosen the collet nut and remove the bit.
- Release the spindle lock if necessary.

SELECTING DEPTH OF CUT

Proper depth of cut depends on several factors: the horsepower of the router motor, the type of bit, and the type of wood. A lightweight, low horsepower router is designed for making shallow cuts; a router with higher horsepower is designed for deeper cuts. Small bits, such as veining bits with 1/16 in. cutting diameters, are designed to remove only small amounts of wood. Large bits, such as straight-flute bits, remove larger amounts of wood and make deeper cuts in soft woods, such as white pine.

Choose a depth of cut that will not place excessive strain on the router motor. If you need extra force or the motor speed slows down considerably, turn off the router and reduce the depth of cut. Then, make the cut in two or more passes.

When routing a groove that is too deep to safely cut in one pass, make the cut in several passes. We recommend that cuts be made at a depth not exceeding 1/8 in. and that several passes be made to reach deeper cuts.

SETTING DEPTH OF CUT FOR FIXED BASE ROUTING

See Figures 6 - 7.

The bit depth can be adjusted by turning the depth adjustment knob clockwise or counterclockwise. The depth of the cut can be read on the depth adjustment knob. Each mark on the scale indicates a 1/64 in. change in depth setting.

- Unplug the router.
- Loosen the lock lever.
- Turn the depth adjustment knob counterclockwise to move the collet down or clockwise to move the collet up.

NOTE: It should not be possible to make depth adjustments with the lock lever tightened. If depth adjustments are possible with the lock lever tightened, an adjustment to the lock lever needs to be made. See *Adjustments*.

- When the desired depth of cut is set, tighten the lock lever.

NOTE: To adjust the depth of cut when the router is mounted to a router table, loosen the lock lever, turn the depth adjustment knob until the bit reaches the desired depth of cut, and retighten the lock lever.

When the router is mounted to a router table, depth adjustments can be made easily by using the supplied T-handle wrench.

To make through table adjustments:

- Unplug the router.
- Loosen the lock lever.

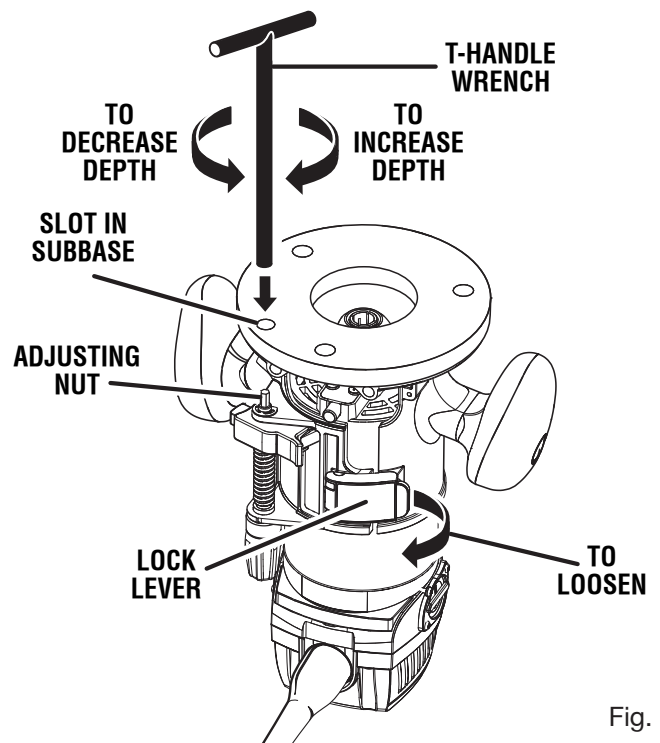
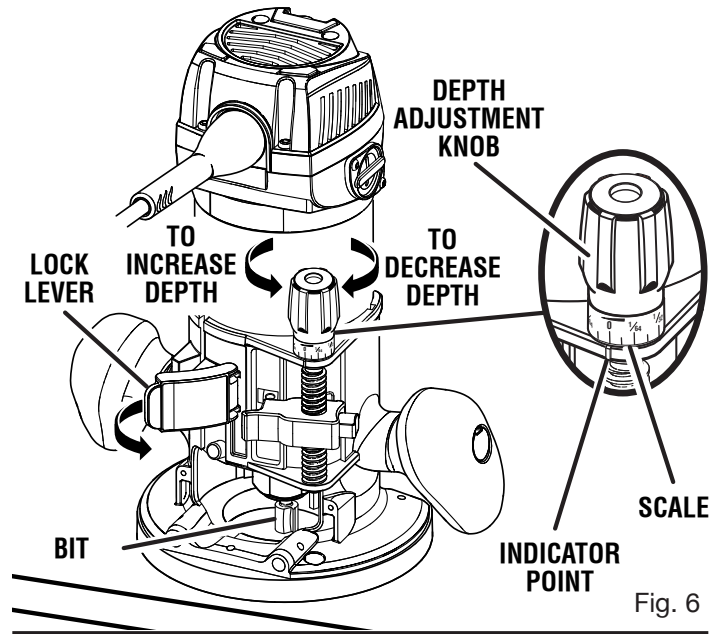

- Insert the T-handle wrench through the hole in the router table into the hole on the subbase, and place the end of the wrench socket over the adjusting nut.
- Turn the wrench counterclockwise to move the collet down or clockwise to move the collet up.

NOTE: It should not be possible to make depth adjustments with the lock lever tightened. If depth adjustments are possible with the lock lever tightened, an adjustment to the lock lever needs to be made. See *Adjustments*.

- When the desired depth of cut is set, tighten the lock lever.

OPERATION

⚠ WARNING:

Do not use with router tables that fail to conform to safe woodworking practices and offer proper guarding for the bit. Use router tables that are UL classified and identified suitable for use with the specific router model. Failure to comply can result in an accident causing possible injury.

⚠ WARNING:

Only use router tables with proper guarding for the bit and with on-board switch controlled receptacles. Failure to use router tables with appropriate safety features could result in serious personal injury.

SETTING DEPTH OF CUT FOR PLUNGE BASE ROUTING

See Figures 8 - 9.

The bit depth can be adjusted on the plunge base with a two way system. The adjustment bar measures bit depth in 1/32 in., while the plunge depth adjustment knob on the plunge base measures depth cuts in 1/64 in.

The plunge base adjustment knob, located on the base of the router, and the adjustment bar, located on the side of the router, make it possible to make deep or heavy cuts in successive passes. A preset cutting depth is achieved by plunging the router until the adjustment bar comes in contact with the plunge base adjustment knob.

The adjustment bar and the plunge base adjustment knob can be used together to find a “zero” depth of cut, or any depth of cut setting that is chosen as a starting point for a particular task.

- Unplug the router.
- Place the plunge base on a flat surface or on the workpiece.
- Loosen the locking arm if needed.
- Loosen the adjustment bar knob.
- Plunge the router to the selected depth, making sure the adjustment bar contacts the plunge depth adjustment knob. This will provide a positive stop at “zero” depth of cut.
- Lock the locking arm if needed.
- Tighten the adjustment bar knob.

NOTE: The depth indicator on the adjustment bar can be reset by loosening the adjustment bar knob and sliding the depth indicator to the desired position. Tighten the adjustment bar knob when depth is set.

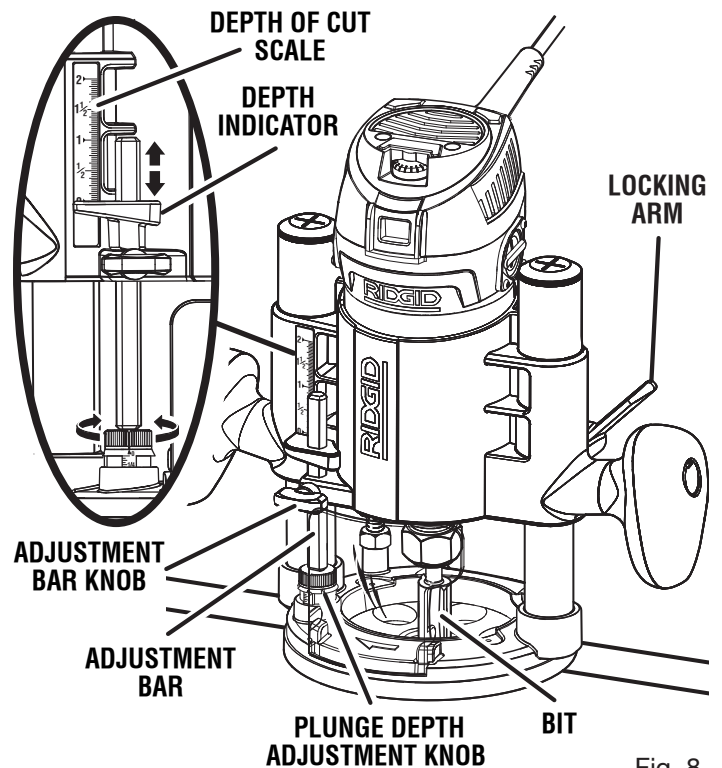

Fig. 8

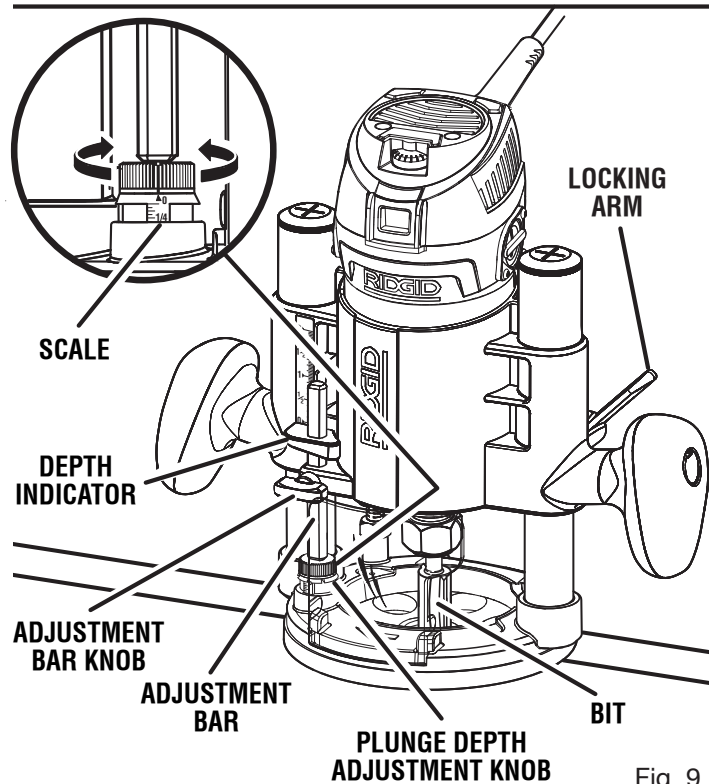

Fig. 9

OPERATION

For further adjustments:

- Unplug the router.
- Unlock the locking arm if needed.
- Loosen the adjustment bar knob.
- Use the depth indicator to measure the desired depth of cut for cuts measurable in 1/32 in.
- Tighten the adjustment bar knob.
- Plunge the router to the selected depth, making sure the adjustment bar contacts the plunge base adjustment knob.
- Retighten the locking arm if needed.

For finer cutting with the plunge depth adjustment knob:

- Unplug the router.
- Unlock the locking arm if needed.
- Loosen the adjustment bar knob.
- Set the plunge depth adjustment knob to the desired setting. Turn clockwise to lower the plunge depth adjustment knob, and counterclockwise to raise it.

NOTE: The plunge base adjustment knob provides depth of cut adjustments from 0-1/2 in. from the highest or lowest setting. Each 90° click on the plunge depth adjustment knob indicates a change in the depth of cut by 1/64 in. A full 360° clockwise rotation on the plunge depth adjustment knob represents 1/16 in.

- Depending on how deep the following cuts will need to be, plunge the router until the tip reaches the desired starting depth of cut using the adjustment bar as a depth stop.

NOTE: This will be the starting depth of cut for the routing work.

- Lock the locking arm if needed.
- Tighten the adjustment bar knob.

For successive cuts:

- Unplug the router.
- Adjust the adjustment bar knob to the desired height.
- Loosen the locking arm if needed.
- Plunge router until plunge depth adjustment knob and adjustment bar touch.
- Retighten locking arm if needed.

TURNING THE ROUTER ON AND OFF

See Figure 10.

The router features a soft start which allows for a gradual increase in speed from 0/min. to the variable speed dial setting. For example, if the router is set at 16,000/min. at the time it is switched off and is then activated again, the motor is designed to gradually rev up to that speed instead of starting out at the full 16,000/min.

To turn the router on, push the switch to the (I), or **ON** position. Return the switch to the (O), or **OFF** position when routing operation is finished.

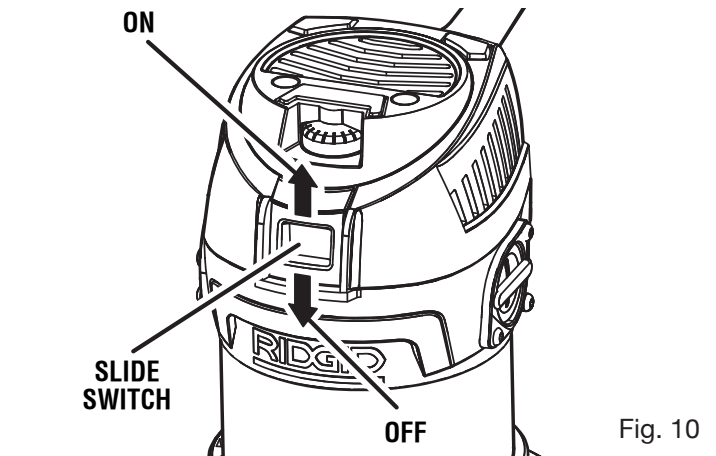

Fig. 10

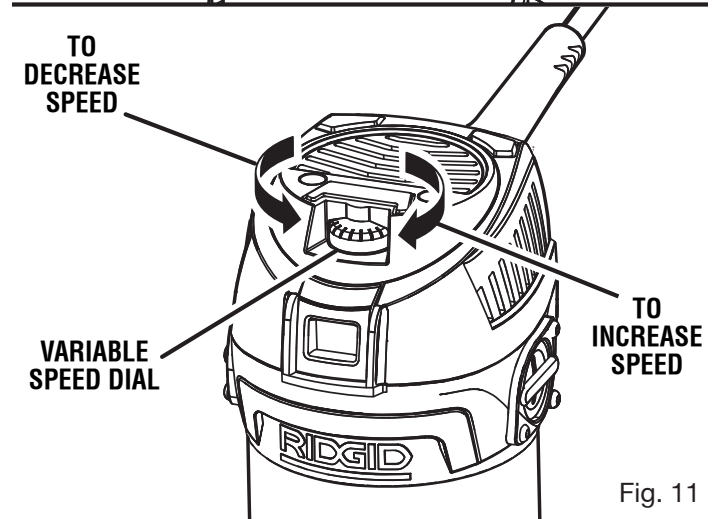

Fig. 11

VARIABLE SPEED DIAL

See Figure 11.

The router has a variable speed dial designed to allow the operator control and adjustment of speed and power limits. The speed and power of the router can be increased or decreased by rotating the variable speed dial in the direction of the arrows shown in figure 11.

NOTE: Hold the router in normal operating position and turn the variable speed dial to the higher numbers to increase speed and power. Turn to the lower numbers to decrease speed and power.

Avoid running the router at low speeds for extended periods of time. Running at low speeds under constant usage may cause the router to become overheated. If this occurs, cool the router by running it without a load and at full speed.

To adjust the router speed, turn the variable speed dial to the desired speed setting.

OPERATION

OPERATING THE ROUTER

See Figures 12 - 13.

When routing straight cuts across a workpiece, clamp a straight edge to the workpiece to use as a guide.

NOTE: Edge guides for the router are also available. See *Accessories*.

Position the straight edge parallel to the line of cut and offset the distance between the cutting edge of the bit and the edge of the router base. Hold the router base against the straight edge and rout the groove.

When routing a groove wider than the diameter of the bit, clamp a straight edge on both sides of the cut lines. Position both guides parallel to the desired line of cut and spaced equal distances from the desired edges of the groove. Rout along one guide then reverse direction and rout along the other guide. Clean out any remaining waste in the center of the groove.

When routing a groove, the travel should be in a direction that places the guide you are using at the right-hand side. When the guide is positioned as shown in the "guide inside" illustration (figure 17), tool travel should be from left to right and counterclockwise around curves. When the guide is positioned as shown in the "guide outside" illustration (figure 17), tool travel should be from right to left and clockwise around curves. If there is a choice, the first setup is generally the easier to use. In either case, the sideways thrust you use is against the guide.

INTERNAL ROUTING

- Tilt router and place on workpiece without the bit contacting the workpiece.
- Turn the router on and let the motor build up to full speed.
- Gradually feed bit into the workpiece until the subbase is level with the workpiece.
- Upon completion of the cut, turn the router off and let the bit come to a complete stop before removing the router from the workpiece.

EDGE ROUTING

- Clamp a straight edge to the workpiece as a guide.
- Place the router on the edge of the workpiece without the bit contacting the workpiece.
- Turn router on and let the motor build up to full speed.
- Gradually feed the bit into the workpiece using the clamped straight edge as a guide.
- Upon completion of the cut, turn the router off and let the bit come to a complete stop before removing the router from the workpiece.

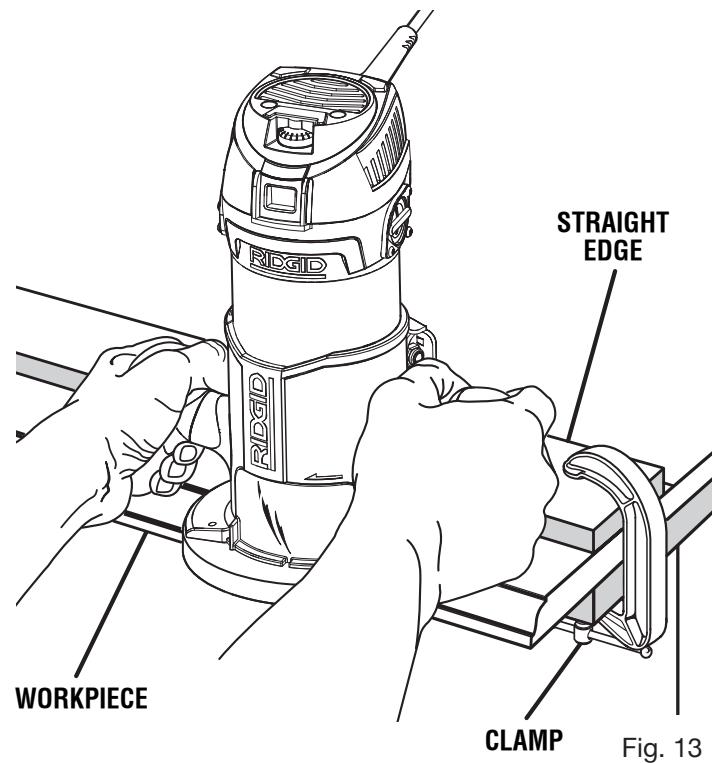
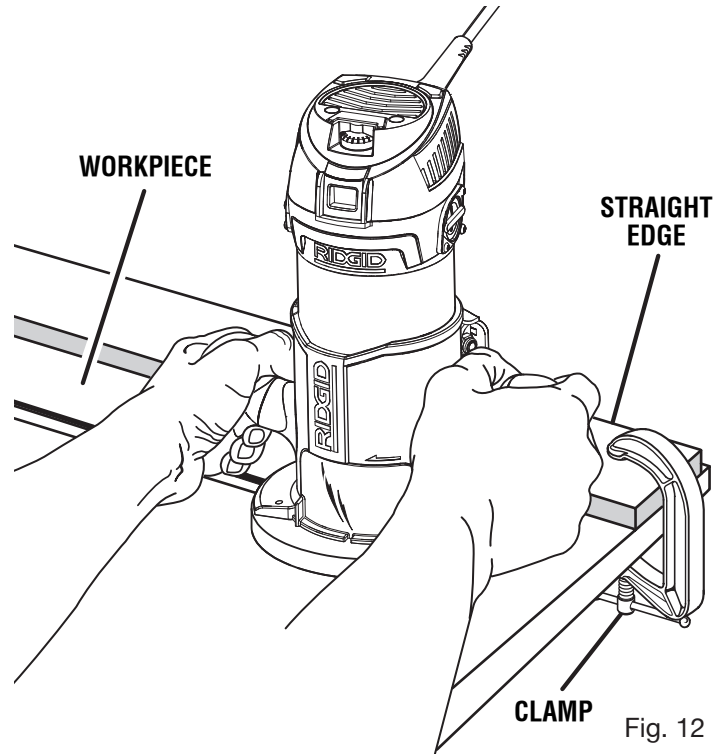

OPERATION

⚠ WARNING:

Do not use large router bits for freehand routing. Use of large router bits when freehand routing could cause loss of control or create other hazardous conditions that could result in personal injury. If using a router table, large bits should be used for edging only.

FREEHAND ROUTING

See Figure 14.

When used freehand, the router becomes a flexible and versatile tool. This flexibility makes it possible to easily rout signs, relief sculptures, etc. When freehand routing:

- Draw or layout the pattern on the workpiece.
- Choose the appropriate bit.

NOTE: A core box or V-groove bit is often used for routing letters and engraving objects. Straight bits and ball mills are often used to make relief carvings. Veining bits are used to carve small, intricate details.

- Rout the pattern in two or more passes. Make the first pass at 25% of the desired depth of cut. This will provide better control as well as being a guide for the next pass.

NOTE: Do not rout deeper than 1/8 in. per pass.

EDGING WITH PILOT BIT

See Figure 15.

The arbor-type bits with pilots are excellent for quick, easy, edge shaping of any workpiece edge that is either straight or curved at a curvature as great or greater than the radius of the bit to be used. The pilot prevents the bit from making too deep a cut; and holding the pilot firmly in contact with the workpiece edge throughout prevents the cut from becoming too shallow.

Whenever the workpiece thickness together with the desired depth of cut (as adjusted by router depth setting) are such that only the top part of the edge is to be shaped (leaving at least a 1/16 in. thick uncut portion at bottom), the pilot can ride against the uncut portion, which serves to guide it. However, if the workpiece is too thin or the bit set too low so that there will be no uncut edge to ride the pilot against, an extra board to act as a guide must be placed under the workpiece. This "guide" board must have exactly the same contour — straight or curved — as the workpiece edge. If it is positioned so that its edge is flush with the workpiece edge, the bit will make a full cut (in as far as the bit radius). On the other hand, if the guide is positioned as shown in figure 15 (out from the workpiece edge), the bit will make less than a full cut — which will alter the shape of the finished edge.

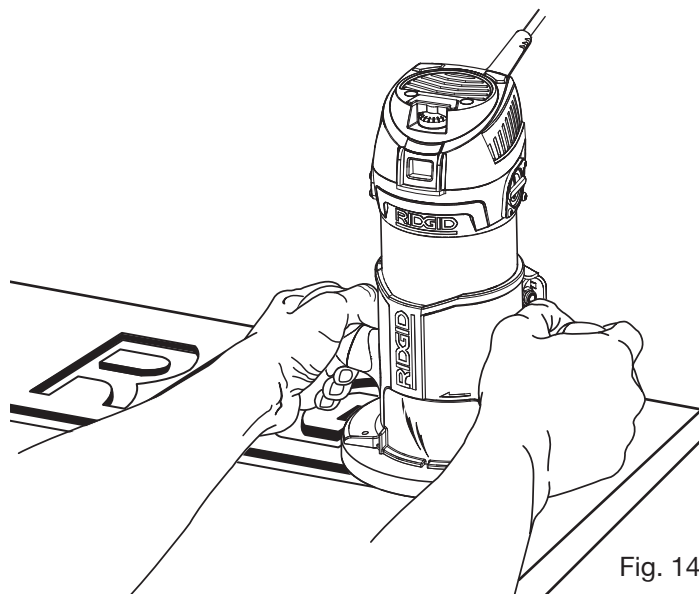

Fig. 14

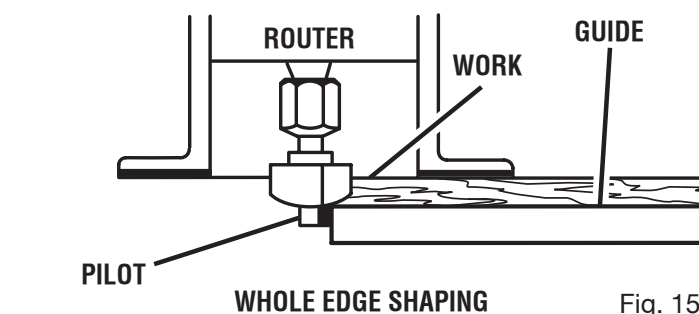
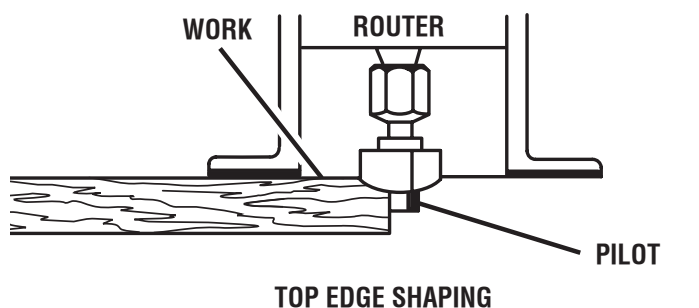

Fig. 15

NOTE: Any of the piloted bits can be used without a pilot for edge shaping with guides, as preceding. The size (diameter) of the pilot that is used determines the maximum cut width that can be made with the pilot against the workpiece edge (the small pilot exposes all of the bit; the large one reduces this amount by 1/16 in.).

OPERATION

DIRECTION OF FEED AND THRUST

See Figures 16 - 17.

The router motor and bit revolve in a clockwise direction. This gives the tool a slight tendency to twist in a counterclockwise direction, especially when the motor revs up.

Feed the router into the workpiece from left to right. When fed from left to right, the rotation of the bit pulls the router against the workpiece. If fed in the opposite direction, the rotation of the spinning bit will tend to throw the router away from the workpiece causing kickback. This could cause you to lose control of the router.

Because of the high speed of bit rotation during a proper feeding operation, there is very little kickback under normal conditions. However, if the bit strikes a knot, hard grain, or foreign object that affects the normal progress of the cutting action, there will be a slight kickback. The direction of kickback is always in the direction opposite bit rotation. This will affect the trueness of the cut.

To guard against kickback, plan the setup and direction of feed so that you will always be thrusting the tool in the same direction that the leading edge of the bit is moving. The thrust should be in a direction that keeps the sharp edges of the bit continuously biting straight into new (uncut) wood.

NOTE: For best results, make sure to take enough time to set up for cutting. While cutting, make sure to use the proper rate of feed.

PROPER RATE OF FEED

Professional routing depends upon careful setup and proper rate of feed which is learned through practice and use. The proper rate of feed is dependent upon:

- hardness and moisture content of the workpiece
- depth of cut
- cutting diameter of the bit

When cutting shallow grooves in soft woods such as pine, a faster rate of feed can be used. When making cuts in hardwoods such as oak, a slower rate of feed is required.

Several factors will help you select the proper rate of feed.

- Choose the rate that does not slow down the motor.
- Choose the rate at which the bit advances firmly and surely to produce a continuous spiral of uniform chips or a smooth edge.
- Listen to the sound of the motor. A high-pitched sound means you are feeding too slowly. A strained, lower pitched sound signals force feeding.
- Check the progress of each cut. Too slow feeding can cause the router to take off in a wrong direction from the intended line of cut. Force feeding increases the strain of holding the tool and results in loss of speed.

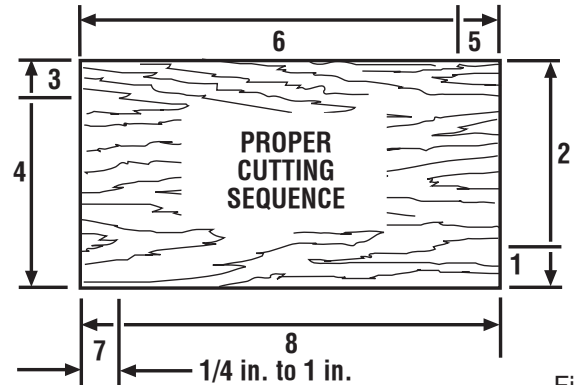

Fig. 16

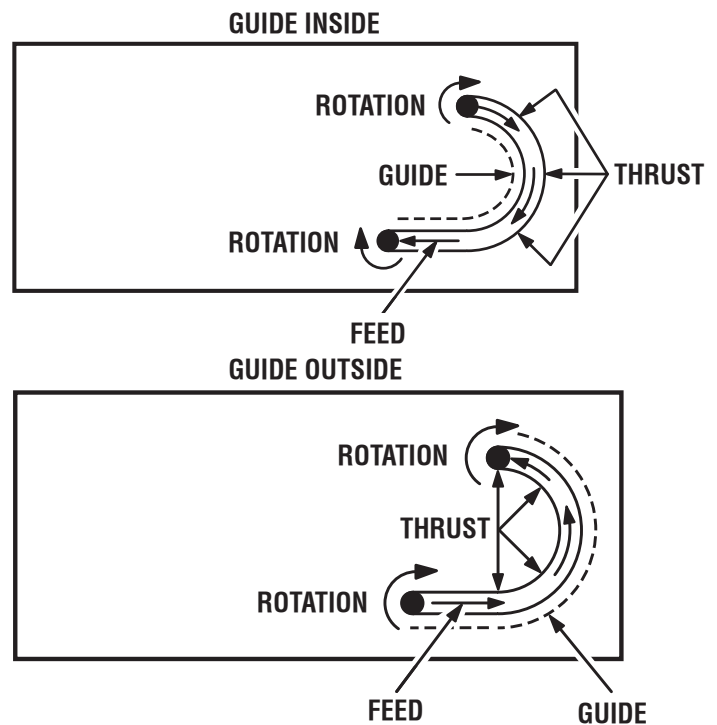

Fig. 17

- Notice the chips being produced as you cut. If the router is fed too slowly, it will scorch or burn the wood. If fed too fast, it will take large chips out of the wood and leave gouge marks.

Test a cut on a scrap piece of the workpiece before you begin. Always grasp and hold the router firmly with both hands.

If you are making a small diameter, shallow groove in soft, dry wood, the proper feed rate may be determined by the speed at which you can travel the router along the guide line. If the bit is a large one, the cut is deep, or the workpiece is hard to cut, the proper feed may be a very slow one. A cross grain cut may require a slower pace than an identical with grain cut in the same workpiece.

OPERATION

FEEDING TOO FAST

See Figure 18.

Clean, smooth routing and edge shaping can be done only when the bit is revolving at a relatively high speed and is taking very small bites to produce tiny, cleanly severed chips. If you force the router to move forward too fast, the RPM of the bit becomes slower than normal in relation to its forward movement. As a result, the bit must take bigger bites as it revolves. Bigger bites mean bigger chips and a rougher finish. Also, because bigger bites require more power, the router motor may become overloaded.

Under extreme force-feeding conditions, the relative RPM of the bit can become so slow—and the bites it has to take so large—that chips will be partially knocked off (rather than fully cut off). This causes splintering and gouging of the workpiece.

The router is an extremely high-speed tool, and will make clean, smooth cuts if allowed to run freely without the overload of a forced feed. You can always detect force feeding by the sound of the motor. Its high-pitched whine will sound lower and stronger as it loses speed. Also, the strain of holding the tool will be noticeably increased.

FEEDING TOO SLOWLY

See Figure 19.

It is possible to spoil a cut by moving the router forward too slowly. When you advance the router into the work too slowly, the revolving bit does not dig into new wood fast enough to take a bite; instead, it merely scrapes away sawdust-like particles. Scraping produces heat, which can glaze, burn, or mar the cut and in extreme cases, can overheat the bit, destroying its hardness.

When the bit is scraping instead of cutting, controlling the router is more difficult. With practically no load on the motor, the bit revolves at close to top RPM, and has a much greater than normal tendency to bounce off the sides of the cut (especially if the wood has a pronounced grain with hard and soft areas). As a result, the cut produced may have rippled, instead of straight, sides.

Feeding too slowly can also cause the router to take off in a wrong direction from the intended line of cut. Always grasp and hold the router firmly with both hands when routing.

You can detect when you are feeding the router too slowly by the runaway, high-pitched sound of the motor or by feeling the wiggle of the bit in the cut.

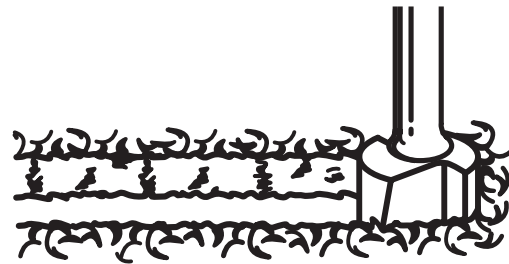

TOO FAST

Fig. 18



TOO SLOW

Fig. 19

OPERATION

DEPTH OF CUT

See Figures 20 - 21.

Depth of cut is important because it affects the rate of feed that, in turn, affects the quality of the cut and the possibility of damage to the tool's motor and bit.

A deep cut requires a slower feed than a shallow one. A cut that is too deep will slow the feed so that the bit is scraping rather than cutting. A too deep cut can cause smaller bits to be broken off. Bits that are 1/16 in. in diameter are easily broken off when subjected to too much side thrust. A large enough bit is not likely to break, but attempting a cut that is too deep may result in a rough cut, and it may be difficult to guide and control the bit as desired. It is recommended that you do not exceed 1/8 in. depth of cut in a single pass, regardless of the bit size or the softness or condition of the workpiece.

To make deeper cuts, make as many successive passes as needed, lowering the bit 1/8 in. for each new pass. To save time, perform all the cutting necessary at one depth setting before lowering the bit for the next pass. This will insure a uniform depth when you complete the final pass.

NOTE: Do not remove more than 1/8 in. in a single pass. Excessive depth of cut can result in loss of control and the possibility of serious personal injury.

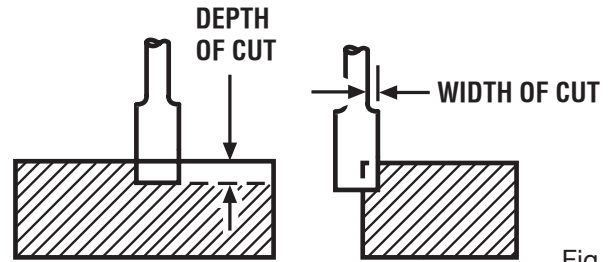

Fig. 20

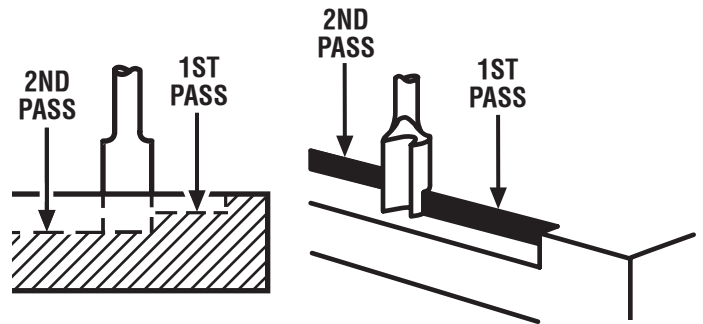

Fig. 21

ADJUSTMENTS

ADJUSTING LOCK LEVER TENSION ON THE FIXED BASE AND PLUNGE BASE ROUTER

See Figure 22.

Over time and with repeated use, the lock lever may become loose. When this occurs, tighten the stop nut slightly. The elastic stop nut should be loose enough so that there is some play in the lock lever when it is in the open position.

NOTE: Do not over tighten the elastic stop nut. The lock lever should clamp tightly to secure the motor housing.

CAUTION:

Make sure the motor housing does not move up or down when clamped. If motor is not securely clamped in base, adjustments will not be accurate.

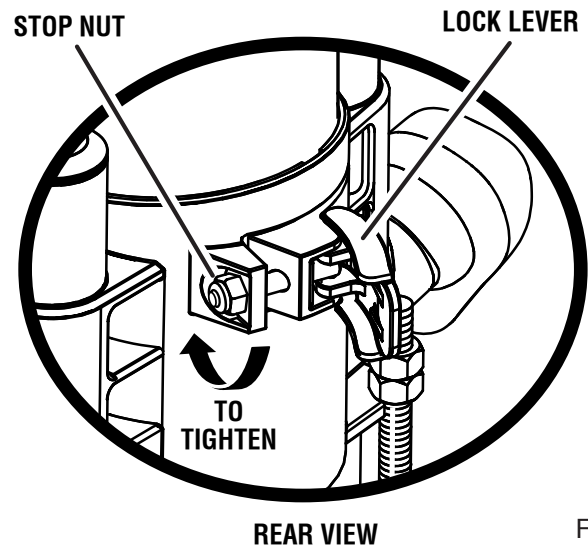

Fig. 22

WARNING:

Follow the provided proper instructions when mounting router to a routing table. Failure to use router tables with appropriate safety features could result in serious personal injury. Use router tables that are UL classified and identified suitable for use with the specific router model.

ROUTER TABLE ATTACHMENT

See Figure 23.

When attaching the router to a routing table, remove the subbase, and use the router table attachment screws provided with the router. Use these screws to replace the sub-base screws shown in figure 23.

ADJUSTMENTS

CENTERING TOOL

See Figure 23.

If the subbase needs to be replaced, removed, or changed, a centering tool is provided. The centering tool is double sided to center the subbase when using the 1/2 in. or 1/4 in. collet.

To remove the subbase on the router:

- Unplug the router.
- Loosen the subbase screws on the base.
- Remove the router subbase.

To install the centering tool and subbase:

- Unplug the router.
- Insert the subbase screws on the base.
- Tighten screws lightly so that the subbase can move freely.
- Using the supplied wrench, hold the collet nut with one wrench or depress and hold the spindle lock until it locks into place.
- Loosen the collet nut.
- Insert the centering tool pin into the collet and tighten the collet securely with the wrench provided.
- Release the spindle lock if necessary.
- Place the cone on the pin and lightly press down on the cone until it stops as shown in figure 23. This will center the subbase.
- While pressing down on the cone, tighten the subbase screws.

To remove the centering tool:

- Unplug the router.
- Using the supplied wrench, hold the collet nut with one wrench or depress and hold the spindle lock until it locks into place.
- Loosen the collet nut and remove the centering tool.
- Release the spindle lock if necessary.

ATTACHING/REMOVING VACUUM ADAPTORS

See Figure 24.

The provided vacuum adaptors provide dust free routing.

To attach/remove the vacuum adaptor to the plunge base:

- Unplug the router.
- Remove the vacuum adaptor screws on the subbase by turning counterclockwise.
- Place the plunge base vacuum adaptor on the plunge base with the screw openings lined up with the screw holes on the bottom of the subbase.
- Reinsert vacuum adaptor screws.
- Turn clockwise to tighten.
- To remove, turn screws counterclockwise.

To attach/remove the vacuum adaptor to the fixed base:

- Unplug the router.
- Using the supplied screws, place the fixed base vacuum adaptor on the fixed base with the openings in the vacuum adaptor lined up with the screw holes on the back of the base.
- Insert the supplied vacuum adaptor screws.
- Turn screws clockwise with a screwdriver to tighten.
- To remove, turn screws counterclockwise.

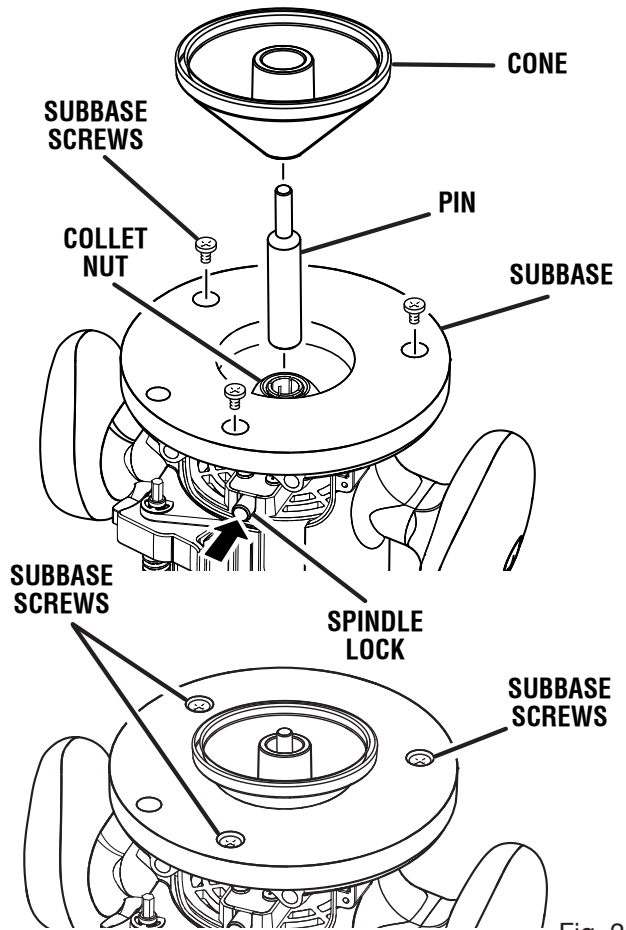

Fig. 23

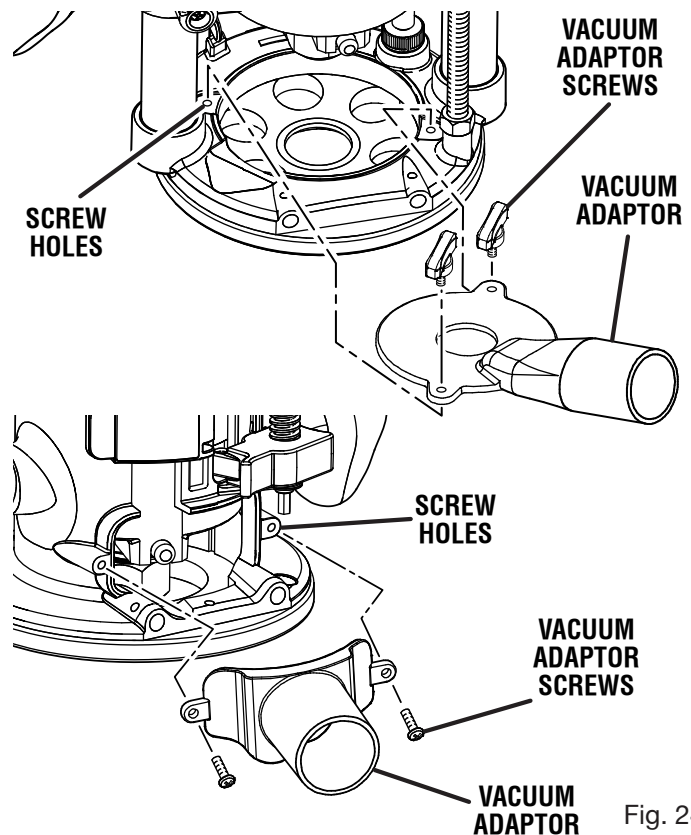

Fig. 24

MAINTENANCE

WARNING:

When servicing use only identical RIDGID replacement parts. Use of any other parts may create a hazard or cause product damage.

WARNING:

Always wear safety goggles or safety glasses with side shields during power tool operation or when blowing dust. If operation is dusty, also wear a dust mask.

GENERAL MAINTENANCE

Avoid using solvents when cleaning plastic parts. Most plastics are susceptible to damage from various types of commercial solvents and may be damaged by their use. Use clean cloths to remove dirt, dust, oil, grease, etc.

WARNING:

Do not at any time let brake fluids, gasoline, petroleum-based products, penetrating oils, etc., come in contact with plastic parts. Chemicals can damage, weaken or destroy plastic which may result in serious personal injury.

ACCESSORIES

Look for these accessories at your local home center:

- Edge Guide Assembly*.....Part no. 300869006
- Plunge Depth Adjustment Knob Extension*.....Part no. 200438001

* Available through customer service only. Call 1-866-539-1710 to order.

Electric tools used on fiberglass material, wallboard, spackling compounds, or plaster are subject to accelerated wear and possible premature failure because the fiberglass chips and grindings are highly abrasive to bearings, brushes, commutators, etc. Consequently, we do not recommend using this tool for extended work on these types of materials. However, if you do work with any of these materials, it is extremely important to clean the tool using compressed air.

LUBRICATION

All of the bearings in this tool are lubricated with a sufficient amount of high grade lubricant for the life of the unit under normal operating conditions. Therefore, no further lubrication is required.

CLEANING THE BITS

Get faster more accurate cutting results by keeping bits clean and sharp. Remove all accumulated pitch and gum from bits after each use. When sharpening bits, sharpen only the inside of the cutting edge. Never grind the outside diameter. When sharpening the end of a bit, be sure to grind the clearance angle the same as originally ground.

CLEANING THE COLLET

From time to time, it becomes necessary to clean the collet and collet nut. To do so, simply remove collet nut from collet and clean the dust and chips that have collected. Then return collet nut to its original position.

COMBINATION
PANEL
BIT



VEINING
BIT



CORE
BOX
BIT



V-GROOVE
CHAMFER



STRAIGHT
FACE
BIT



COMBINATION
STRAIGHT/BEVEL
BIT



HINGE
MORTISING
BIT



DOVETAIL
BIT



WARNING:

Current attachments and accessories available for use with this tool are listed above. Do not use any attachments or accessories not recommended by the manufacturer of this tool. The use of attachments or accessories not recommended can result in serious personal injury.

WARRANTY

RIDGID® HAND HELD AND STATIONARY POWER TOOL 3 YEAR LIMITED SERVICE WARRANTY

Proof of purchase must be presented when requesting warranty service.

Limited to RIDGID® hand held and stationary power tools purchased 2/1/04 and after. This product is manufactured by One World Technologies, Inc. The trademark is licensed from RIDGID, Inc. All warranty communications should be directed to One World Technologies, Inc., attn: RIDGID Hand Held and Stationary Power Tool Technical Service at (toll free) 1-866-539-1710.

90-DAY SATISFACTION GUARANTEE POLICY

During the first 90 days after the date of purchase, if you are dissatisfied with the performance of this RIDGID® Hand Held and Stationary Power Tool for any reason you may return the tool to the dealer from which it was purchased for a full refund or exchange. To receive a replacement tool you must present proof of purchase and return all original equipment packaged with the original product. The replacement tool will be covered by the limited warranty for the balance of the 3 YEAR service warranty period.

WHAT IS COVERED UNDER THE 3 YEAR LIMITED SERVICE WARRANTY

This warranty on RIDGID® Hand Held and Stationary Power Tools covers all defects in workmanship or materials and normal wear items such as brushes, chucks, motors, switches, cords, gears and even cordless batteries in this RIDGID® tool for three years following the purchase date of the tool. Warranties for other RIDGID® products may vary.

HOW TO OBTAIN SERVICE

To obtain service for this RIDGID® tool you must return it; freight prepaid, or take it in to an authorized service center for RIDGID® branded hand held and stationary power tools. You may obtain the location of the authorized service center nearest you by calling (toll free) 1-866-539-1710 or by logging on to the RIDGID® website at www.ridgid.com. When requesting warranty service, you must present the original dated sales receipt. The authorized service center will repair any faulty workmanship, and either repair or replace any part covered under the warranty, at our option, at no charge to you.

WHAT IS NOT COVERED

This warranty applies only to the original purchaser at retail and may not be transferred. This warranty only covers defects arising under normal usage and does not cover any malfunction, failure or defect resulting from misuse, abuse, neglect, alteration, modification or repair by other than an authorized service center for RIDGID® branded hand held and stationary power tools. Consumable accessories provided with the tool such as, but not limited to, blades, bits and sand paper are not covered.

RIDGID, INC. AND ONE WORLD TECHNOLOGIES, INC. MAKE NO WARRANTIES, REPRESENTATIONS OR PROMISES AS TO THE QUALITY OR PERFORMANCE OF ITS POWER TOOLS OTHER THAN THOSE SPECIFICALLY STATED IN THIS WARRANTY.

ADDITIONAL LIMITATIONS

To the extent permitted by applicable law, all implied warranties, including warranties of MERCHANTABILITY or FITNESS FOR A PARTICULAR PURPOSE, are disclaimed. Any implied warranties, including warranties of merchantability or fitness for a particular purpose, that cannot be disclaimed under state law are limited to three years from the date of purchase. One World Technologies, Inc. and RIDGID, Inc. are not responsible for direct, indirect, incidental or consequential damages. Some states do not allow limitations on how long an implied warranty lasts and/or do not allow the exclusion or limitation of incidental or consequential damages, so the above limitations may not apply to you. This warranty gives you specific legal rights, and you may also have other rights which vary from state to state.

One World Technologies, Inc.

Hwy. 8

Pickens, SC 29671

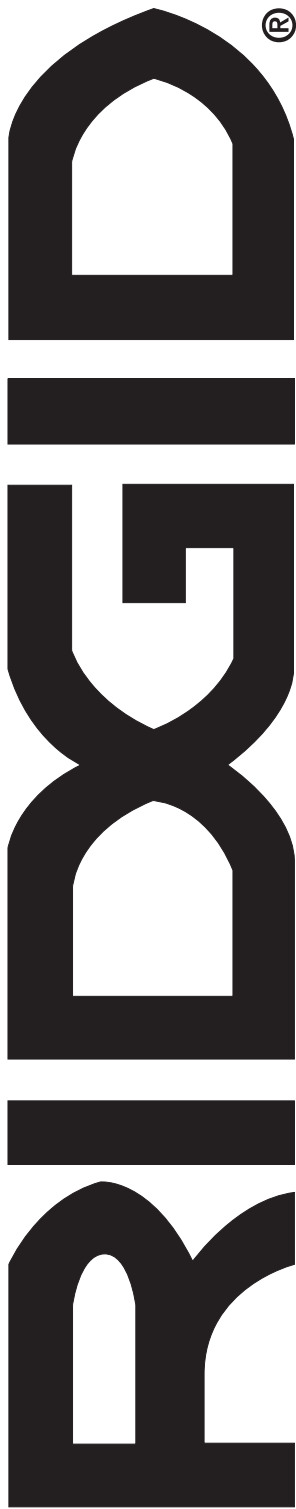

OPERATOR'S MANUAL

ROUTER

WITH FIXED AND PLUNGE BASES

DOUBLE INSULATED

R2900

Customer Service Information:

For parts or service, contact your nearest RIDGID authorized service center. Be sure to provide all relevant information when you call or visit. For the location of the authorized service center nearest you, please call 1-866-539-1710 or visit us online at www.ridgid.com.

The model number of this tool is found on a plate attached to the motor housing. Please record the serial number in the space provided below. When ordering repair parts, always give the following information:

Model No. R2900
 Serial No.

Free Manuals Download Website

<http://myh66.com>

<http://usermanuals.us>

<http://www.somanuals.com>

<http://www.4manuals.cc>

<http://www.manual-lib.com>

<http://www.404manual.com>

<http://www.luxmanual.com>

<http://aubethermostatmanual.com>

Golf course search by state

<http://golfingnear.com>

Email search by domain

<http://emailbydomain.com>

Auto manuals search

<http://auto.somanuals.com>

TV manuals search

<http://tv.somanuals.com>