



MODEL 5100-XX-IT

IT Series

TOXIC GAS SENSOR MODULE

Version 2.0

APPLICABILITY & EFFECTIVITY

Effective for all Model 5100-XX-IT and 5100-XX-IT-SS Modules manufactured after March 1, 2008 including.

**5100-03-IT
5100-04-IT
5100-05-IT
5100-06-IT**

**Instruction Manual Part Number T12020
Rev A**

THIS PAGE INTENTIONALLY LEFT BLANK

TABLE OF CONTENTS

1. PRODUCT DESCRIPTION	1
1.1 GENERAL.....	1
1.2 PRODUCT CONFIGURATION.....	1
1.3 THEORY OF OPERATION.....	1
1.4 MODES OF OPERATION.....	1
1.4.1 SENTRY INTERFACE.....	1
1.4.2 MODBUS OPERATION.....	2
1.4.3 ANALOG OPERATION.....	2
1.4.4 REMOTE SENSOR AND DISPLAY (APPENDIX D).....	2
1.4.5 REMOTE ALARM RESET (DIGITAL INPUT) (Figure 3-7).....	2
1.4.6 OPTIONAL INTEGRAL RELAYS.....	2
MECHANICAL.....	2
1.4.7 ENCLOSURE.....	2
1.4.8 TRANSMITTER ELECTRONICS.....	4
1.4.9 SENSOR ASSEMBLY.....	4
1.5 INTERCONNECT WIRING.....	4
1.6 POWER REQUIREMENTS.....	4
2. CAUTIONS & WARNINGS	5
2.1 INTRODUCTION.....	5
2.2 IT MODULES - GENERAL.....	5
2.3 WIRING.....	5
3. INSTALLATION	7
3.1 SENSOR MODULE LOCATIONS.....	7
3.2 WIRING.....	7
3.2.1 ANALOG 4-20 mA OPERATION.....	7
3.2.2 MODBUS OPERATION USING RS-485 CONNECTION.....	7
3.2.3 SENTRY OPERATION USING SMC SENTRY CONNECTION.....	7
3.2.4 GENERAL.....	7
3.3 ENCLOSURE INSTALLATION.....	8
3.4 TRANSMITTER AND SENSOR INSTALLATION.....	8
3.5 MODULE ADDRESS SWITCH.....	10
4. OPERATION	17
4.1 INTRODUCTION – HUMAN-MACHINE INTERFACE SYSTEM.....	17
4.2 HUMAN-MACHINE INTERFACE.....	17
4.3 MAIN MENU.....	18
4.4 CONFIGURE SET-POINTS.....	19
4.5 MAINTENANCE FUNCTIONS.....	22
5. CALIBRATION	24
5.1 CALIBRATION FREQUENCY.....	24
5.2 CALIBRATION PREPARATION.....	24
5.2.1 CALIBRATION GAS DELIVERY METHODS.....	24
5.3 CALIBRATION PROCEDURE.....	24
5.3.1 SENSOR EXPOSURE TO GAS.....	25
6. SERVICE	26
6.1 SENSOR MODULE CONFIGURATION.....	26
6.2 ENCLOSURE REPLACEMENT.....	26
6.3 TRANSMITTER REPLACEMENT.....	27
6.4 SENSOR REPLACEMENT.....	27

6.5	INSTALLATION INSPECTION	27
6.5.2	INSPECTION AND TROUBLESHOOTING GUIDE	28
6.5.3	IF MODULE DOES NOT RESPOND TO GAS	28
6.5.4	IF THE MODULE DISPLAYS "STARTING" FOR MORE THAN 1 HOUR	28
7.	APPENDICES	29
	APPENDIX A - SPECIFICATIONS	29
	APPENDIX B: - MODEL NUMBERS & PARTS LIST	31
	APPENDIX C: LIMITED WARRANTY	32
	APPENDIX D: REMOTE SENSOR/DISPLAY DRAWING 5394-52	33
	APPENDIX E: MODBUS MEMORY MAP	34

1. PRODUCT DESCRIPTION

1.1 GENERAL

The Model 5100-XX-IT Toxics Gas Sensor Module is a member of the **Information Technology "IT"** family of gas sensor transmitter modules. Members of the IT Toxics family include:

- 5100-03-IT Oxygen Deficiency Gas Sensor Module
- 5100-04-IT Carbon Monoxide Gas Sensor Module
- 5100-05-IT Hydrogen Sulfide Gas Sensor Module
- 5100-06-IT Chlorine Gas Sensor Module

IT modules offer a broad array of features, including:

- Integral alphanumeric LED display
- 180 day calibration frequency
- 4-20 mA output
- Modbus[®] RTU interface
- SMC Sentry interface
- 316 Stainless steel enclosure option
- Auxiliary integral relay option
- Remote display option
- Low maintenance and operation costs

IT modules are designed, and approved for installation and operation in hazardous locations.

1.2 PRODUCT CONFIGURATION

Various module configuration options are available. Where applicable, these options are factory configured prior to shipment. Options which can be re-configured by the installer or field technician are fully described in this manual.

1.3 THEORY OF OPERATION

Electrochemical sensors are fuel cell-like devices consisting of an anode, cathode and electrolyte. The components of the cell are selected so a subject gas, allowed to diffuse into the cell, will cause a chemical reaction and generate a current. The cells are diffusion limited so the rate the gas enters the cell is solely dependent on the gas concentration. The current generated is proportional to the rate of consumption of the subject gas in the cell.

1.4 MODES OF OPERATION

1.4.1 SENTRY INTERFACE

IT gas sensor modules can be installed on Sierra Monitor Sentry Model 5000 controllers. The gas sensor module communicates as a toxic gas sensor module (Type 4 – communication) and are automatically detected by the Sentry controller. When it is installed in a Sentry system the IT module must have a unique address which can be established by setting an address between 1 and 8 on the Module Address Switch



accessible from the cover plate as illustrated in Figure 3-1. Figure 3-6 in this manual provides the wiring terminations for connections to the Sentry controller.

When the module is operated in conjunction with a Sentry controller, the alarms outputs in the module can both be set to "Sentry", allowing the Sentry controller to manage alarm acknowledge and reset rather than the sensor module. The alarm relay outputs are triggered by the alarm values established in the module, and can be independent of the settings in the Sentry controller.

The Sentry configuration allows daisy chain installation using the Sentry multiplex capability, thus reducing costs by avoiding the requirement for wiring junction boxes. The connector card has two sets of connections, allowing for a continuous run to the next module.

1.4.2 MODBUS OPERATION

An RS-485 Modbus RTU serial interface allows direct connection to standard PLCs and DCSs. The Module Address Switch (section 3.5) allows the user to select up to 16 different Modbus addresses. Also, an additional 238 Modbus addresses (for a total of 254 different Modbus Addresses) are available via menu selection. Figure 3-6 in this manual provides the wiring terminations for Modbus connections. The 5100-XX-IT provides the additional terminal connectors to enable the user to connect In/Out terminations of a RS-485 connection.

1.4.3 ANALOG OPERATION

The 4-20 mA interface allows direct connection to standard analog controllers or PLCs. The 5100-XX-IT 4-20 mA connection can be wired as a Type 3 (3-wire) or Type 4 (4-wire) circuit as described by ANSI/ISA-50.00.01-1975 Standard (see figure 3-5).

1.4.4 REMOTE SENSOR AND DISPLAY (APPENDIX D)

The Remote Sensor and Display option (5394-52) can be used to remotely mount the sensor up to 100' from the transmitter.

1.4.5 REMOTE ALARM RESET (DIGITAL INPUT) (Figure 3-7)

An input is available for connection of remote alarm reset/acknowledge. Figure 3-4 provides the wiring termination for connecting the remote alarm reset. This only resets local alarms, not Sentry alarms. This input can be wired as supervised or non-supervised.

Note that when the Remote Alarm Reset is operated in a supervised mode that both the switch and resistor must be present as outlined in Figure 3-7.

1.4.6 OPTIONAL INTEGRAL RELAYS

The optional relays are integral to the gas sensor module and are rated as SPDT, 250VAC, 8 Amps for the High Alarm and Low Alarm relays and SPDT, 250 VAC, 2 Amp for the Trouble relay.

If the gas sensor module is provided with the optional relays, it will include Terminal P4 on the interface board (Figure 3-2). Relay output connections are on P4.

MECHANICAL

The sensor module of comprised of the following three primary components:

1.4.7 ENCLOSURE

Standard on the 5100-XX-IT is an explosion-proof, rain-tight cast aluminum electrical housing (Figure 1-1) with three ¾" FNPT conduit hubs. The 5100-XX-IT-SS (Figure 1-2) has a 316 Stainless Steel enclosure. Both enclosure covers have a viewing window. The design of the enclosure allows 3-way mounting choices as shown in figure 1-3.

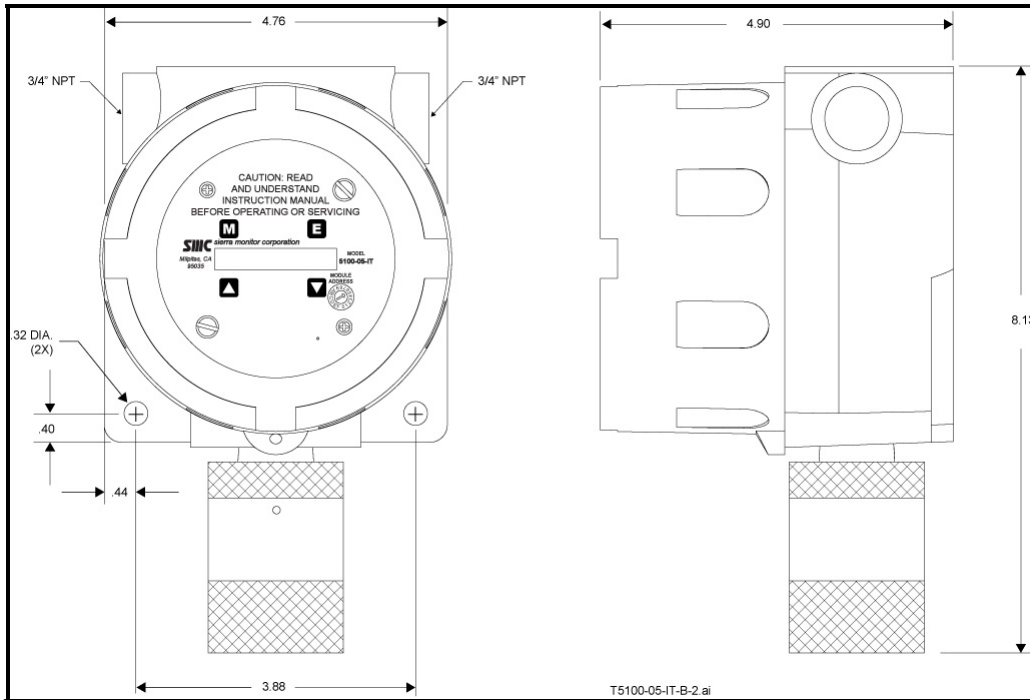

Figure 1-1
Model 5100-05-IT Toxic Gas Sensor Module – Aluminum Enclosures, Dimensions

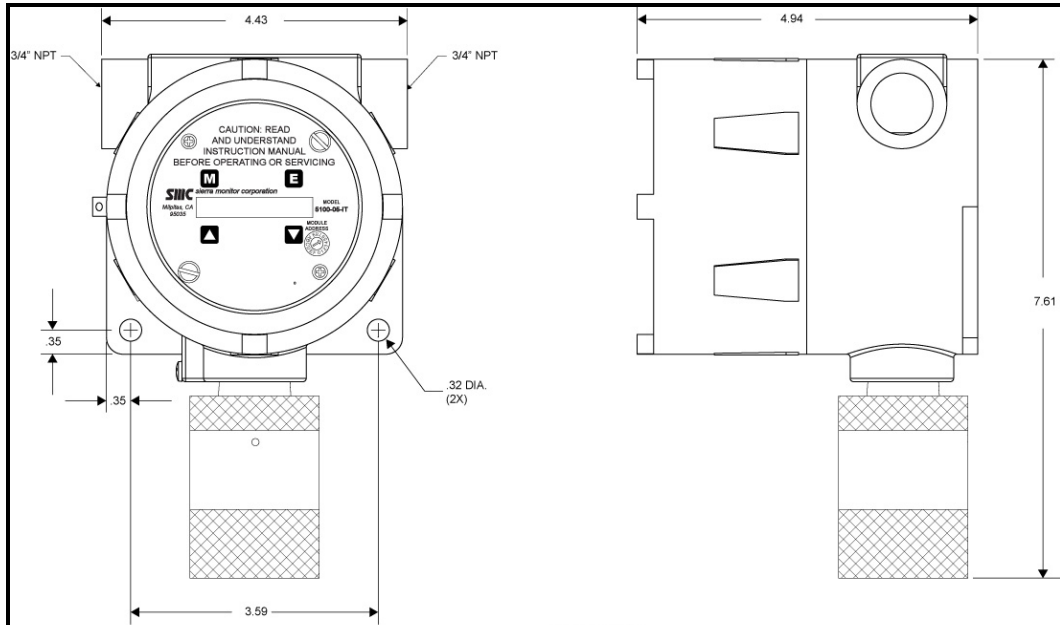
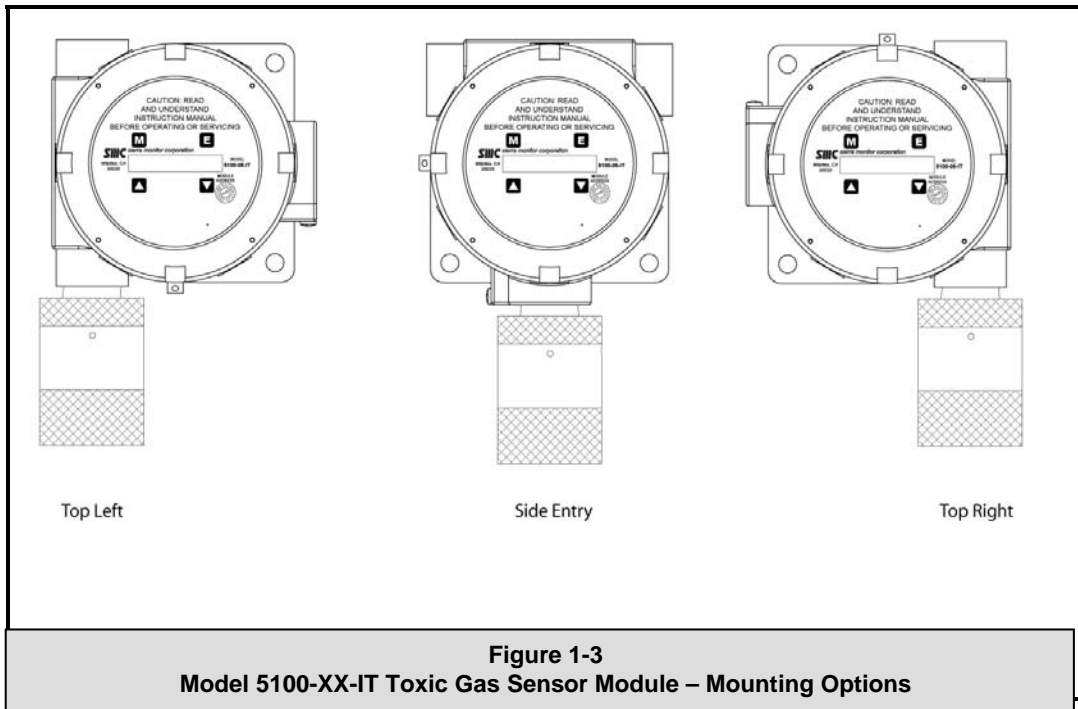

Figure 1-2
Model 5100-05-IT Toxic Gas Sensor Module – 316 Stainless Steel Enclosures, Dimensions



1.4.8 TRANSMITTER ELECTRONICS

Electronic Assembly consist of one top transmitter board (connected to the cover plate) and on lower interface board. Connectors for wiring for power, signal interface and alarm relays are located on the interface board assembly

1.4.9 SENSOR ASSEMBLY

The sensor assembly includes an explosion proof housing containing the gas sensor and a wiring harness for connection to the transmitter. The sensor assembly threads into one hub of the enclosure. The exposed end of the sensor assembly is threaded to allow connection of a rain-shield or calibration gas delivery fitting.

1.5 INTERCONNECT WIRING

Not supplied with the sensor module, but necessary to the installation and operation is the multi conductor wiring which connects the module to its power source and controller. Before this wiring is installed it is important to read and understand the control system installation instructions to determine wiring requirements and alternatives.

1.6 POWER REQUIREMENTS

IT modules operate on DC power between 10 VDC and 30 VDC. Regulated DC power must be supplied from a separate source, or from an approved Sentry or **IT** controller.

2. CAUTIONS & WARNINGS

2.1 INTRODUCTION

Although *IT* Transmitter Modules are designed and constructed for installation and operation in industrial applications including "hostile" environments, caution should be taken to insure that the installation is made in compliance with this instruction manual and that certain procedures and conditions are avoided. This chapter discusses the necessary cautions. **Read the entire chapter prior to installation of the equipment.**

2.2 IT MODULES - GENERAL

Avoid installing sensor modules where they will be unnecessarily exposed to wind, dust, water (esp. direct hose down), shock, or vibration. Observe temperature range limitations.

Sensors may be adversely affected by prolonged exposure to certain materials. Loss of sensitivity, or corrosion, may be gradual if such materials are present in low concentrations. These materials include: Halides (compounds containing chlorine, fluorine, bromine, iodine), acid vapors, caustic liquids or mists.

Care has been taken by the manufacturer to ship your modules in protective packaging to avoid contamination prior to installation. It is recommended that the modules remain protected during installation and that the covering be removed immediately prior to system start-up.

During normal use the sensor is protected from dirt and oil contamination by a sintered metal cover. If this cover becomes clogged, the response of the sensor will be reduced. Protect the sensor from contamination by careful placement, or by use of rain and dust shields.

Sensor modules must not be painted. Paint may contain compounds which will contaminate the sensor. Paint will cause clogging of the sintered metal cover and will cause difficulties during attachment of the calibration head or other maintenance activity. It is recommended that the module be tagged "**DO NOT PAINT**".

2.3 WIRING

The manufacturer recommends that extra caution be taken where the installation is near any sources of electromagnetic or radio frequency interference. Precautions include:

- Avoid running sensor module cable close to high power cables, radio transmission lines, or cables subject to pulses of high current.
- Avoid running cables near large electric motors or generators.
- When the sensor module is to be operated in analog (4-20mA output) mode shielded cable is required.
- When the risk of interference is present use shielded cables. In conduit installations the shield should be connected to the conduit. In cable applications the shield should be connected to the cable connector.
- All splices must be via either a termination hardware system or soldered. Improperly spliced cable can result in corrosion, resistance changes and system errors.

NOTE

Installation and wiring must be in accordance with the National Electrical Code. AC Voltage conductors are not to be run in the same conduit as DC voltage conductors.

THIS PAGE INTENTIONALLY LEFT BLANK

3. INSTALLATION

NOTE

*All IT modules are factory are pre-configured and calibrated.
All modules are tagged to indicate the configuration including the sensor module number.
Identify all components during unpacking and install using the factory configuration.*

3.1 SENSOR MODULE LOCATIONS

Select locations for each sensor modules based on the following:

- Modules should be placed close to the potential source of gas.
- Modules should be placed in areas accessible for calibration.
- Sensors should be pointed down and the conduit should include an inverse trap to reduce moisture (condensation) from accumulating in the electronics enclosure.
- Remote calibration fitting (5360-00) should be used to facilitate calibration gas delivery. Run polyurethane tubing (1/4" O.D. x 1/8" I.D.) from fitting to an accessible location.

3.2 WIRING

3.2.1 ANALOG 4-20 mA OPERATION

The 4-20 mA output for the 5100-XX-IT can be either 3-wire or 4-wire operation. If using 3-wire operation, use a minimum of 18 AWG, shielded, 3-conductor cable up to 2000'. For 4-wire operation, use a minimum of 2 each, 18 AWG, twisted, shielded, pair up to 2000'.

3.2.2 MODBUS OPERATION USING RS-485 CONNECTION

Use a minimum of 18 AWG, 2 conductor for DC power connection. No shield required. In addition use a minimum of 24 AWG, low capacitance, shielded data cable for RS-485 half duplex communication. The installation may be planned in a manner which provides up to 32 sensor modules on a single home run.

Refer to Figure 3-3 units ship with BIAS jumpers connected. For all installations, except very long cable runs, these jumpers connected. The TERM jumpers should be installed in the last (furthest) module of every loop.

3.2.3 SENTRY OPERATION USING SMC SENTRY CONNECTION

Wire shall be rated as 600 volt tray cable, such as Belden (or equivalent) 27331 or 27331 AS (shielded). If high RFI or EMI levels exist wiring should be protected by conduit or shield. The installation may be planned in a manner which provides up to 4 sensor modules on a single home run to a Sentry controller.

NOTE:

Be sure to follow all local electric code and safety requirements when installing the 5100-XX-IT Gas Sensor Module

3.2.4 GENERAL

Install conduit as required by local code or construction specifications. When sensor modules are to be multiplexed for Sentry or RS-485 communication two alternatives may be planned:

- Install splice boxes above each sensor module. Use multi-position positive contact terminals to connect daisy chain wiring and provide a pigtail to connect to the sensor module transmitter board.

NOTES

The drain wire of shielded cable must NOT be used as one of the conductors.

Installation and wiring must be in accordance with the National Electrical Code. Temperature rating of cable wire must be at least 75°C. If cable runs through higher temperature environments, it must be specified for that environment.

3.3 ENCLOSURE INSTALLATION

To protect the transmitter and sensor assembly they should be removed from the enclosure and preserved until final installation and wiring termination.

Prior to installation and wiring.

1. Remove the transmitter from the module housing by:
 - Unscrew the two captive panel screws in the face plate.
 - Lift the transmitter out of the housing.
 - Unplug the sensor cable from transmitter connector P2.
 - Remove the sensor assembly from the enclosure hub.
2. Install the module housing onto the end of the supply conduit and/or bolt into position as required.

NOTES

When housing earth grounding is required for the installation a grounding lug is located in the base of the enclosure. Install the earth ground wire under the green lug.

When installing the enclosure be sure to mount the FM Approved plate near the sensor enclosure. This plate states "Caution: this area must be known to be free of flammable concentrations prior to opening the enclosure."

3.4 TRANSMITTER AND SENSOR INSTALLATION

When all pre-wire is complete:

1. Install sensor assembly in the open hub on the module enclosure. The sensor assembly thread must be fully seated into the hub and tightened to maintain explosion proof assembly.
2. Connect the wires which return to the controller to interface board connectors P1, P2, P3 and P4 according to Figure 3-2.
3. Connect the sensor assembly cable to top transmitter board connector P2.
4. Align the headers between the top transmitter board and the lower interface board and push together.
5. Turn rotary switch to correct sensor address.

NOTE

The interface board should be wired to remote controllers first before installing the front transmitter board.

6. Carefully return the transmitter to the enclosure installing it over the two stand-offs. Tighten the retaining screws into the stand-offs.

P1	PCB Label	Function
1	Switch	IN +
2		IN -
3	4-20	IN +
4		IN -
5	GND	Ground
6	4-20	OUT +
7		OUT -

P2	PCB Label	Function
1	RS 485	+
2		-
3		S
4	RS 485	+
5		-
6		S

P3B	PCB Label	Function
1	P	Power
2	S	Signal
3	G	Ground
P3A		
4	P	Power
5	S	Signal
6	G	Ground

P4 Connections are only available when the optional Relays are included

P4	PCB Label	Function
1	LO ALM	N/C
2		COM
3		N/O
4	HI ALM	N/C
5		COM
6		N/O
7	TRBL ALM	N/C
8		COM
9		N/O
* Trouble relay is fail safe so it is energized for normal operation, functions are labeled for normal operation.		
Table 3-1 Sensor Module External Interfaces (See Figure 3-2)		

7. Establish the module address according to section 3.5.

NOTE

The starting delay period normally takes approximately 3 minutes but under some circumstances can take longer.

3.5 MODULE ADDRESS SWITCH

For digital interface applications the module address switch (or Modbus node) must be set per Table 3-2:

POSITION	ADDRESS	POSITION	ADDRESS
1	Sensor 1	9	Sensor 09
2	Sensor 2	A	Sensor 10
3	Sensor 3	B	Sensor 11
4	Sensor 4	C	Sensor 12
5	Sensor 5	D	Sensor 13
6	Sensor 6	E	Sensor 14
7	Sensor 7	F	Sensor 15
8	Sensor 8	0	Software Menu

**Table 3-2
Sensor Module Address Switch Positions**

NOTE

For Sentry applications only sensor addresses 1-8 are allowed. If using Modbus output sensor addresses 1-15 are available. Position 0 allows the Modbus Address to be set by software menu, in the range 16-254.

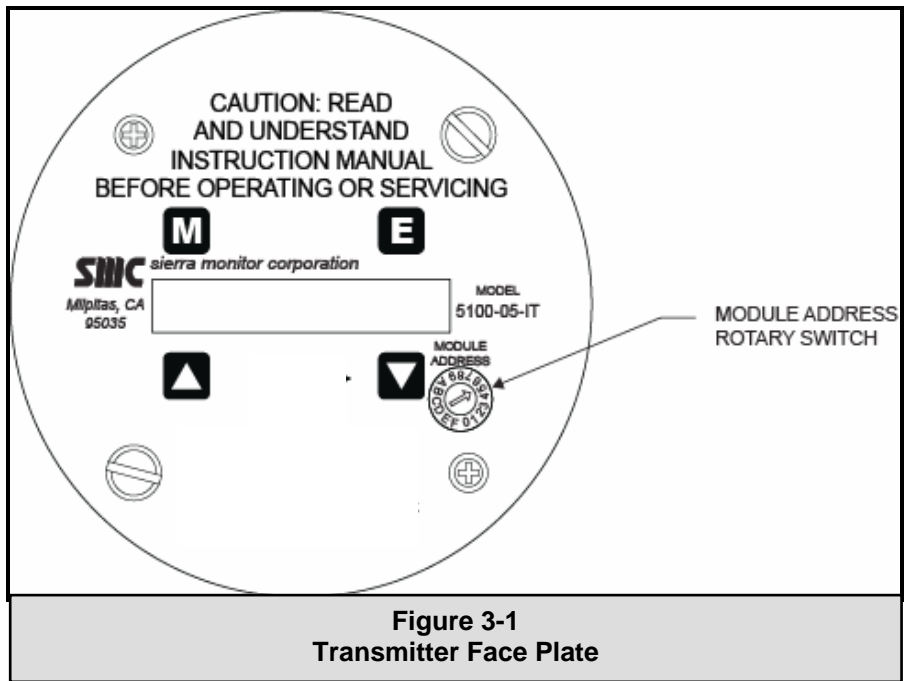

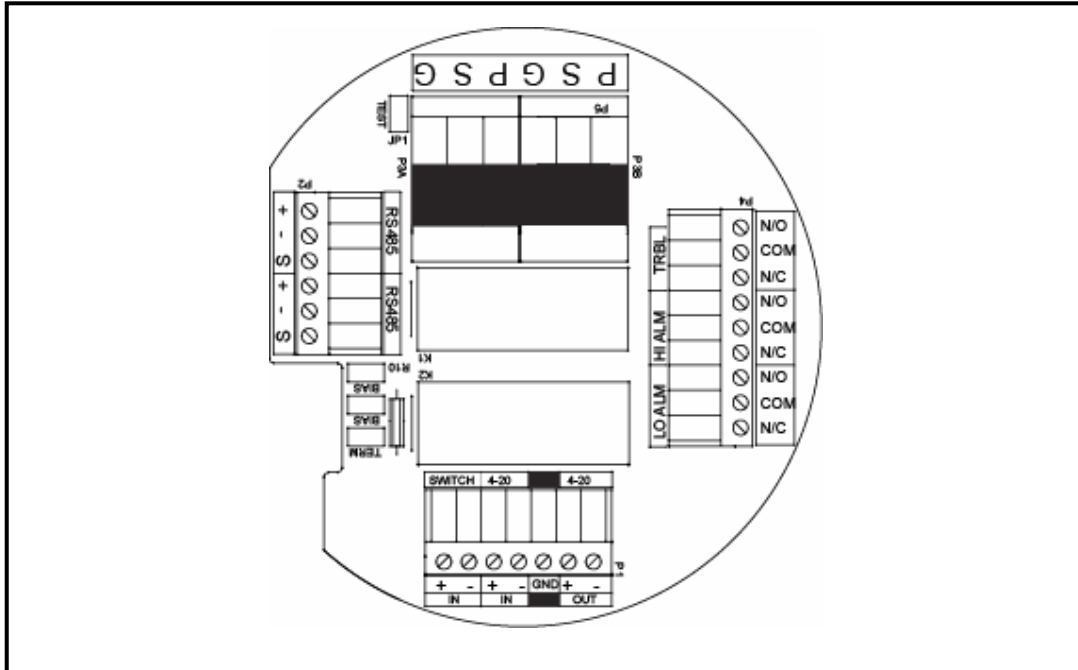
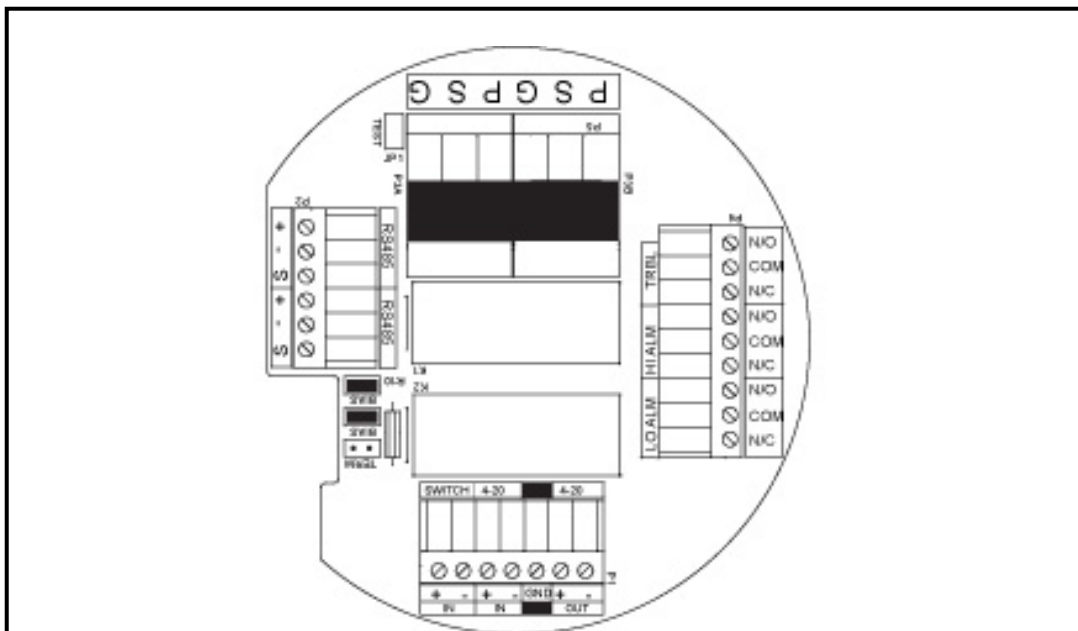

Figure 3-2
Interface Board Connectors



RS485 APPLICATION:
TERM REMOVED FOR NO TERMINATION (120 OHM), ADD JUMPER FOR TERMINATION.
BIAS SHUNTED FOR 100K OHM BIAS.

Figure 3-3
RS-485: 120 ohm termination not selected, BIAS shunted for 100K ohm bias

TYPE 3 CIRCUIT (3 WIRE)

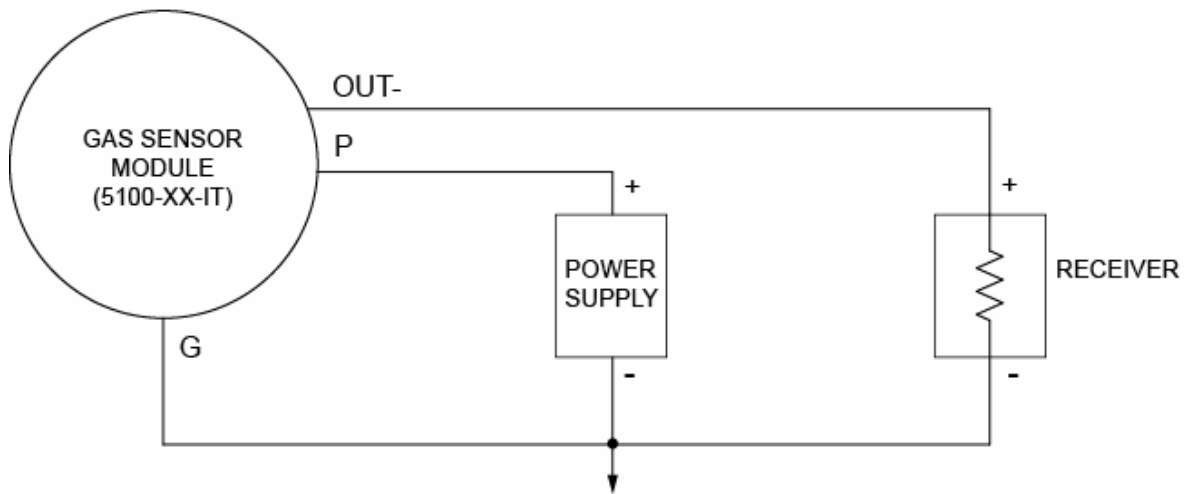

TYPE 4 CIRCUIT (4 WIRE)

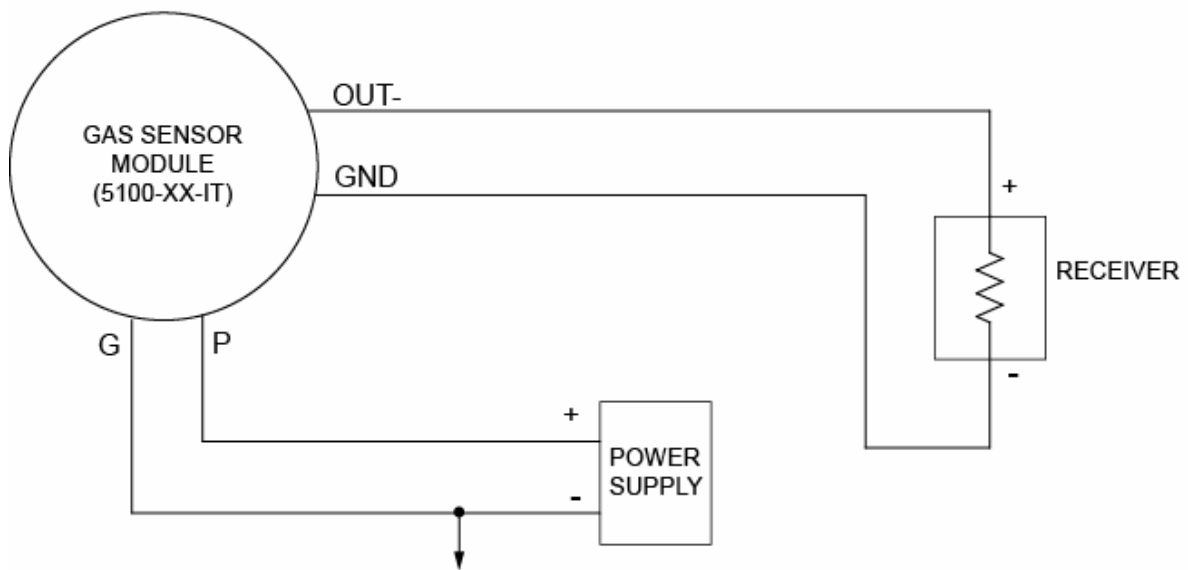
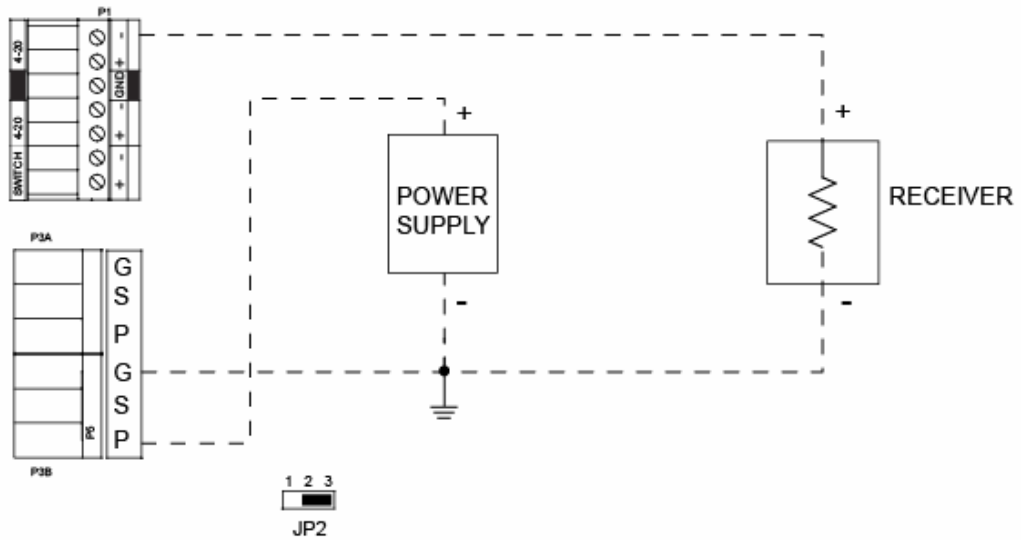

Figure 3-4
4-20mA Circuit Types

TYPE 3 CIRCUIT (3 WIRE)



TYPE 4 CIRCUIT (4 WIRE)

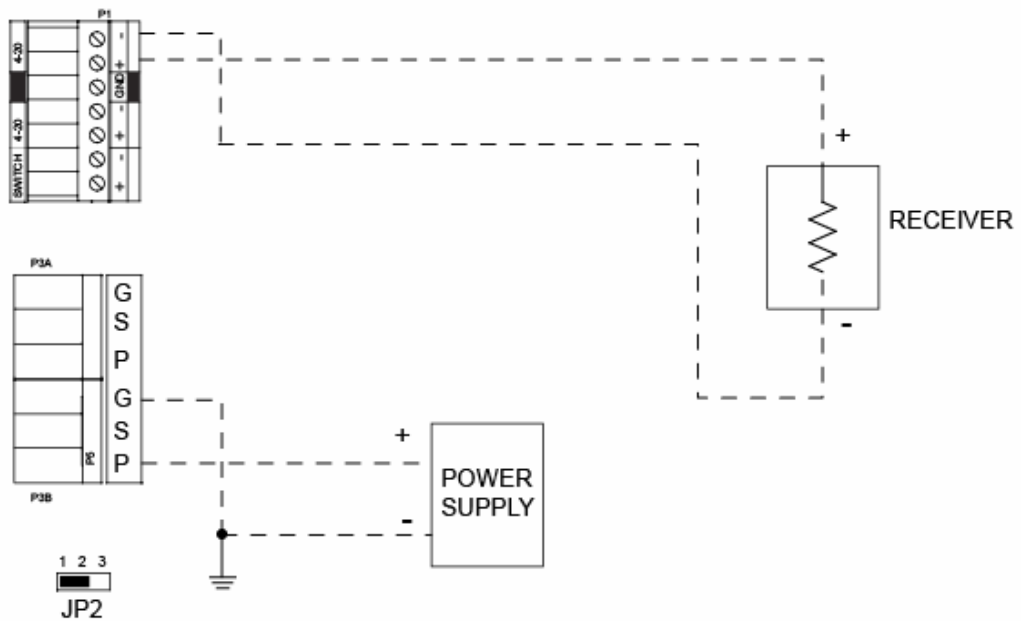
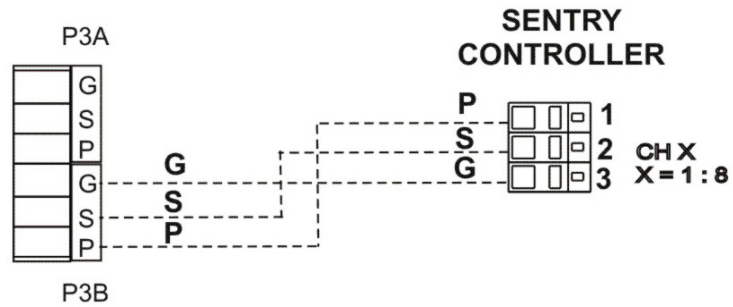
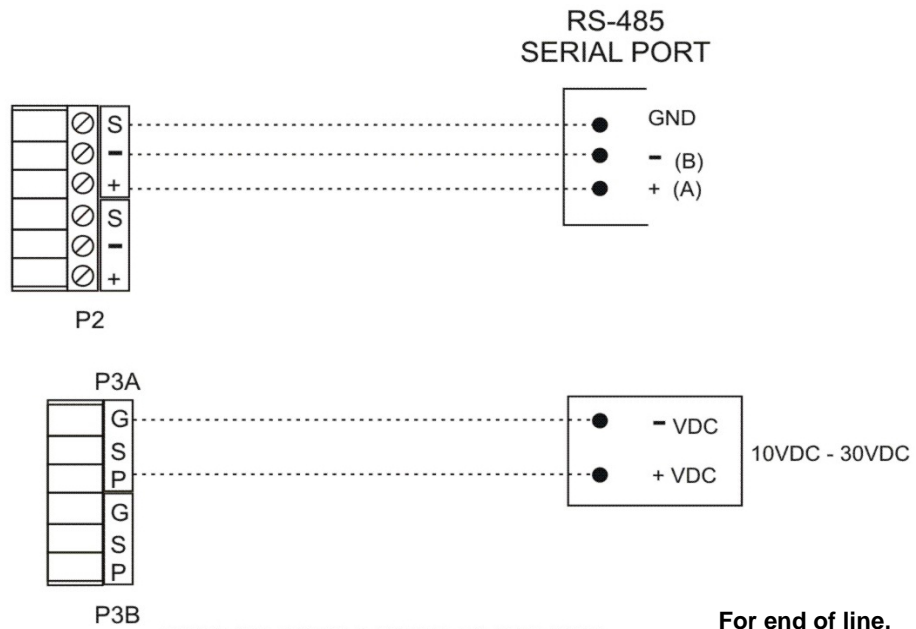

Figure 3-5
4-20mA Circuit Type Connections for 5100-XX-IT



5100-05-IT TO SENTRY



5100-05-IT TO MODBUS DEVICE

For end of line,
refer to Figure 3-3

Figure 3-6
Wiring Connections for Modbus and Sentry Interface

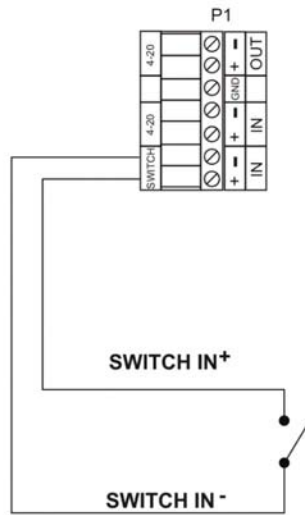

5100-05-IT REMOTE ALARM RESET (UNSUPERVISED)

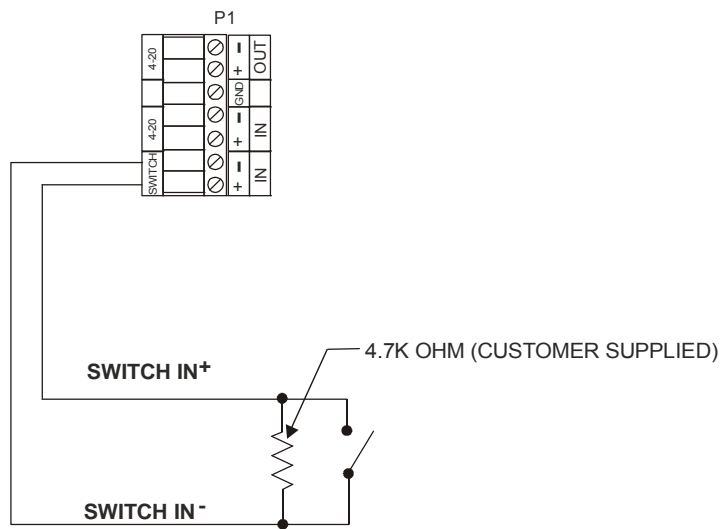

5100-05-IT REMOTE ALARM RESET (SUPERVISED)

Figure 3-7
Wiring Connections for Remote Alarm Reset

THIS PAGE INTENTIONALLY LEFT BLANK

4. OPERATION

4.1 INTRODUCTION – HUMAN-MACHINE INTERFACE SYSTEM

The Gas Sensor Module utilizes a visual menu system operated by means of a magnet. A magnetic tool (5358-50) is supplied for this purpose. The menu system is used to configure alarm set-points, calibrate the sensor module, and for maintenance procedures and alarms acknowledge.

4.2 HUMAN-MACHINE INTERFACE

The module menu system is operated by means of directing the magnet stick toward each of four independent hall-effect magnetic switches. Each switch functions as if it is a manually activated panel key. The keys are located above and below the faceplate display and are labeled **M**, **E**, **▲** and **▼** as shown in Figure 4-1. The key functions are as follows:

- Key **M**: **MODE**
- Key **E**: **ENTER**
- Key **▲**: **UP (+)**
- Key **▼**: **DOWN (-)**

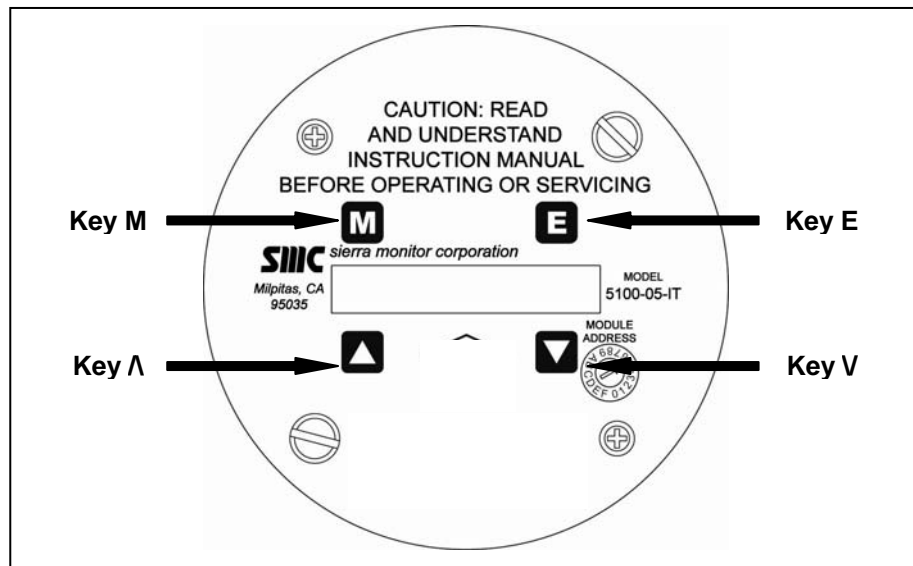

Figure 4-1:
IT Module – Menu Switch Locations

4.3 MAIN MENU

Table 4-1 describes the primary man-machine interface operation.

Key	Function	Display	Description	Reference
M E ▲ ▼	Mode		Switch [M]	
M E ▲ ▼	Enter		Switch [E]	
M E ▲ ▼	Up		Switch [▲] Previous Menu	
M E ▲ ▼	Down		Switch [▼] Next Menu	
		5100-XX	First screen at power up: Model No.	
		VXX-XX--	Second screen at power up: Version No.	
		STARTING	Third screen at start up: Starting Delay	
		XXXPPM	Normal condition - default display	
M E ▲ ▼	Mode	ALMRSET:	Mode Function - Alarm Reset	
			Banner: "Press [E] to reset alarm"	
M E ▲ ▼		RESET	Alarm Reset	
		XXXPPM	Default Display	
M E ▲ ▼	Mode	ALMRSET:	Mode Function - Alarm Reset	
M E ▲ ▼	Mode	CALIB:--	Mode Function - Calibrate	Table 5-1
M E ▲ ▼	Mode	SETUP:--	Mode Function - Set Point Adjustments	Table 4-3
M E ▲ ▼	Mode	MAINT:--	Mode Function - Maintenance	Table 4-4
M E ▲ ▼	Mode	EXIT-?--	Exit Menu	
M E ▲ ▼	Enter	XXXPPM	Apply Selected Mode (Exit)	
		XXXPPM	Default Display (Once a minute the sensor displays module address)	

Table 4-1 Master Menu

Table 4-2 describes the operational display values of the human-machine interface system.

DISPLAY	DESCRIPTION
STARTING	Delay from loss of power at start-up
XXX PPM	Concentration
LXXXPPM	Low Alarm
HXXXPPM	High Alarm
HIGH	Measures gas, concentration exceeds 100% to Full Scale
CXXXPPM	Calibration Mode
ACK	Acknowledged Function

Table 4-2 Operation Display Values

4.4 CONFIGURE SET-POINTS

The sensor module set-points menu is used to initially set-up the alarm set points, relay actions, gas type and range, 4-20 mA action and RS-485/Sentry address and baud rates.

- **Alarm Set-points:** Once the Set-up menu is selected, press [E] to activate the Alarm Set-point screen. Use the [▲] or [▼] keys to select Low Alarm or High Alarm menu. Key [▲] will adjust the setpoint upwards and Key [▼] will adjust the value downwards. Once it reaches the desired setpoint, Key [E] will accept it and ACK will appear.

Set-points can be configured using this menu up to the following values:

5100-03-IT	O ₂	19.5%
5100-04-IT	CO	500 PPM
5100-05-IT	H ₂ S	20 PPM
5100-06-IT	Cl ₂	5 PPM

- **Alarm Relay Set-up:** Once the Set-up menu is selected, press key [▼] once and press [E] to activate the Relay Set-up menu. Use the [▲] or [▼] keys to select High Alarm or Low Alarm relay menu and press [E]. Use the [▲] or [▼] keys to select the correct alarm relay action for the application, Latch, Sentry or Non-Latch. Selecting "Sentry" enables the Sentry controller to make all alarm action decisions. * indicates the current selection.
- **Range:** Once the Set-up menu is selected, press key [▼] twice and press [E] to activate the Range Set-up menu. Use the [▲] or [▼] keys to select Range menu and press [E]. When "Range" is selected menu provides any choices of ranges available for the gas type selected. Use the [▲] or [▼] keys to select the desired range. If the "User" range is selected, use the [▲] or [▼] keys to adjust the high end of the range desired.
- **4-20mA:** Once the Set-up menu is selected, press key [▼] three times and press [E] to activate the 4-20mA Set-up menu. Use the [▲] or [▼] keys to select Calib or CalibOut menu and press [E]. The "Calib" section of the menu allows the user to calibrate the 4 mA and 20 mA outputs. To calibrate the 4 mA and 20 mA outputs it is necessary to have an amp meter connected to the 5100-XX-IT and upon selecting the 4 mA output calibration then the [▲] or [▼] keys can be used to adjust the 4 mA reading on the amp meter until it reads 4 mA. Similar steps can then be performed for the 20 mA output. The CalibOut section allows the user to select the 4-20 mA output action desired during calibration. * indicates the current selected value. Available selections include:
 - **Track** – the 4-20mA value tracks the calibration gas exposed to the gas sensor module
 - **Zero** – the 4-20mA value is held at 0mA during calibration
 - **C1.50mA** – the 4-20mA value is held at 1.50mA during calibration
 - **C4.00mA** – the 4-20mA value is held at 4.0mA during calibration.
- **RS-485** - Once the Set-up menu is selected, press key [▼] four times and press [E] to activate the RS-485/Sentry Set-up menu. Use the [▲] or [▼] keys to select Address or Baud rate menu and press [E]. Note that the 5100-XX-IT has a rotary switch on the faceplate and it is used to select addresses 1-15. When connected to Sentry the user can select 1-8 and using Modbus RS-485 the user can select addresses 1-15. For Modbus addresses above 15, set the rotary switch to 0 and then use the "Address" menu to select any address between 16 and 254. The Baud rate menu allows the user to select a baud rate of 38400, 19200, 9600, 4800 or 2400. * indicates current selection.

Key	Function	Display	Description	Reference
		--0%LEL-	Default Display	
M ▲▼	Mode	ALMRSET:	Mode Function - Alarm Reset	
M ▲▼	Mode	CALIB:--	Mode Function - Calibrate	
M ▲▼	Mode	SETUP:---	Mode Function - Set Point Adjustments	
M ▲▼	Enter	Alarms	S.P. Function - Alarm Adjust	* A Below
M ▲▼	Down	Relays	S.P. Function - Relays Adjust	* B Below
M ▲▼	Down	Gas	S.P. Function - Range Adjust	* Page 21
M ▲▼	Down	4-20mA	S.P. Function - 4-20 mA Adjust	* Page 21
M ▲▼	Down	RS-485	S.P. Function - RS-485/Sentry Output Adjust	* Page 21
High Alarm Set Point Adjustment Example				
M ▲▼	Enter	H.Alarm	S.P. Function - High Alarm Adjust	*A
M ▲▼	Enter	HASP:60-	High Alarm Set Point: current = 60	
			Use ▲ or ▼ keys to adjust to new set point	
M ▲▼	Down (x5)	HASP:55-	High Alarm Set Point: new = 55	
M ▲▼	Enter	ACK	Momentary Acknowledge of new Set Point	
		H.Alarm	S.P. Function - High Alarm Adjust	
Relays Set Point Adjustment Example				
M ▲▼	Enter	H. Relay	S.P. Function - High Alarm Relay Adjust	*B
M ▲▼	Down	L.Relay	S.P. Function - Low Alarm Relay Adjust	
M ▲▼	Enter	Latch	Use ▲ or ▼ keys to adjust to new relay action (Latch, Sentry, NonLatac) * indicates current	
M ▲▼	Down	Sentry	NOTE: Sentry indicates that Sentry controls relay action and not the IT Sensor Module	
M ▲▼	Down	*Sentry	High Alarm Relay set to Sentry	
Table 4-3A Set-Up Configuration				

Gas Range Adjustment Example				
M E	Enter	Range	S.P. Function - Range Adjust	*C
▲ ▼				
M E	Enter	*100 PPM	Select [E] to select or ▲ or ▼ to select another and press [E]	
▲ ▼				
M E	Down	10 PPM	Press [E] if selecting 0-10 PPM range	
▲ ▼				
M E	Down	USER	Press [E] if selecting User adjustable range	
▲ ▼				
M E	Enter	100 PPM	Select [E] to select or ▲ or ▼ to select another and press [E]	
▲ ▼				
4-20 mA Adjustment Example				
M E	Enter	Calib	S.P. Function - Calib Adjust	*D
▲ ▼				
M E	Enter	Out: 4mA	Use ▲ or ▼ keys to select 4 mA or 20mA	
▲ ▼				
M E	Enter	4mA	Selects 4 mA	
▲ ▼				
M E	Enter	ACK	Momentary Acknowledge of new Set Point	
▲ ▼				
M E	Mode	Calib	S.P. Function - Calib Adjust	
▲ ▼				
M E	Down	CalibOut	S.P. Function - Output during Calibration Adjust	
▲ ▼				
M E	Enter	Track	Use ▲ or ▼ keys to select Track, Zero, C1.50mA, C4.00mA	
▲ ▼			Track = Output during calibration tracks the calibration gas, Zero = Output is Zero during calibration, C1.50mA = Output during calibration is 1.50 mA, C4.00mA = Output during calibration is 4.0 mA	
M E	Enter	*Track	* = Current selection	
▲ ▼				
RS-485 Adjustment Example				
M E	Enter	Address	S.P. Function - RS-485 Address Adjust	*E
▲ ▼				
M E	Enter	Addr:016	Use ▲ or ▼ keys to enter new address	
▲ ▼				
M E	Enter	ACK	New address selected	
▲ ▼				
M E	Enter	Address	S.P. Function - RS-485 Address Adjust	
▲ ▼				
M E	Down	Baud	S.P. Function - RS-485 Baud Rate Adjust	
▲ ▼				
M E	Enter	*38400	Press [E] to select or [▲] or [▼] to select another	
▲ ▼				
Table 4-3B Set-Up Configuration				

4.5 MAINTENANCE FUNCTIONS

The maintenance menu enables the operator to view sensor and software versions. Sierra Monitor technical support has access to other values as needed.. The maintenance menu operation is described in Table 4-4.

Key	Function	Display	Description	Reference
		XXXPPM	Default Display	
M E ▲ ▼	Mode	ALMRSET:	Mode Function - Alarm Reset	
M E ▲ ▼	Mode	CALIB:--	Mode Function - Calibrate	
M E ▲ ▼	Mode	SETUP:-	Mode Function - Set Point Adjustments	
M E ▲ ▼	Mode	MAINT:--	Mode Function - Maintenance	
M E ▲ ▼	Enter	Ver1.00aA	Module Software Version Number	
M E ▲ ▼	Enter	CCC001	Module Custom Configuration Control number	

**Table 4-4
Maintenance Menu**

THIS PAGE INTENTIONALLY LEFT BLANK

5. CALIBRATION

5.1 CALIBRATION FREQUENCY

The 5100-XX-IT has been calibrated in the factory prior to shipment. It is recommended that the user check calibration before placing in service. The toxic sensor module must be calibrated every six months. Periodic functional tests are advisable for critical applications and hostile environments.

The sensor module microprocessor software includes high level self checking algorithms which provide continuous sensor diagnostic and self adjustment. Users may elect to increase calibration periods based on low drift experience during the first two calibration periods.

5.2 CALIBRATION PREPARATION

Calibration of the Toxic Gas Sensor Module is accomplished by simple menu based steps and application of span gas.

NOTE
If an error is made during any stage of the calibration process, hold the magnet stick at the Switch [M] for 10 seconds. A scrolling display will indicate "Calibration aborted" and the sensor module will exit the calibration activity and return to normal operating mode. The calibration procedure can then be restarted

Calibration must be performed only when the area is known to be clear of the applicable toxic gas. If necessary, use a portable instrument to confirm that there is no background toxic gas.

For compliance with Factory Mutual (FM) Apparatus, the Sierra Monitor Model 1250-01, 1256-01, 1260-XX are the only FM Approved calibration gas delivery device. Use Model 5358-00 or 5358-01 Calibration Adapter or Model 5360-00 Gas Delivery Fitting.

5.2.1 CALIBRATION GAS DELIVERY METHODS

Calibration gas can be delivered to the sensors via the following delivery devices:

Model 5358-00: Calibration Adapter - used with portable calibrators. See 5-1.

Model 5360-00: Calibration Gas Delivery fitting - permanently installed fitting which allows tubing to be run to a convenient delivery location

5.3 CALIBRATION PROCEDURE

Table 5-1 shows the step by step process of the calibration procedure.

The procedure requires that the menu "keys" be activated using the magnet stick. Each key press steps through the process of setting the zero value for clean air and then setting the span value.

At each of these steps, apply calibration gas of the value corresponding to the setting accepted on the sensor module display.

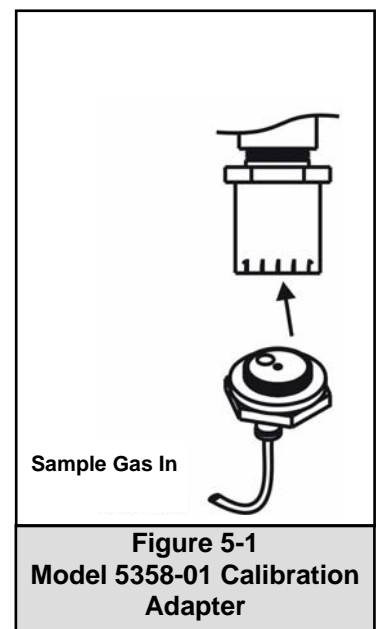

5.3.1 SENSOR EXPOSURE TO GAS

Calibration gas must be delivered to the sensor using the flow rate and duration listed in below:

Model	Gas	Flow	Period
5100-03-IT	Oxygen	300 cc/min	Until Stable
5100-04-IT	Carbon Monoxide	300 cc/min	Until Stable
5100-05-IT	Hydrogen Sulfide	300 cc/min	Until Stable
5100-06-IT	Chlorine	300 cc/min	Until Stable

Key	Function	Display	Description	Reference
		XXXPPM	Default Display	
M E ▲ ▼	Mode	ALMRSET:	Mode Function - Alarm Reset	
M E ▲ ▼	Mode	CALIB:--	Mode Function - Calibrate	
M E ▲ ▼	Enter	CAL-0PPM-	Banner: Apply zero gas, enter <E> when done	
			<i>Operation: Confirm area clear of gas, or apply zero air to sensor.</i>	
M E ▲ ▼	Enter	ACK	Zero gas setting acknowledged	
		10PPM-SP	Banner: Select span, enter <E> to calibrate sensor	Sub A
M E ▲ ▼	Enter	C 4 PPM	Banner: Apply span gas, then enter <E> to calibrate gas sensor	Sub B
		C 4 PPM	<i>Operation: Apply calibration gas.</i>	
		CXXXPPM	<i>Operation: As gas is applied the reading will increase - wait 3 minutes</i>	
M E ▲ ▼	Enter	CAL-OK	Calibration Passed - now remove gas	
		WAIT-300	<i>Operation: Five minute time out before sensor is returned to service.</i>	
Sub-Routines				
		10PPM-SP	Banner: Select span, enter <E> when done	Sub A
M E ▲ ▼	Up	25PPM-SP	<i>Operation: Change Span Gas Value to 25PPM</i>	
M E ▲ ▼	Up	Adj-SPAN	<i>Operation: User adjustable value</i>	
M E ▲ ▼	Enter	25PPM-SP	<i>Operation: Ready for user adjustment</i>	
M E ▲ ▼	Enter	C 25PPM	Banner: Apply 25PPM gas, then enter <E> to calibrate gas sensor	Sub B
		C 25PPM	<i>Operation: Apply calibration gas.</i>	
M E ▲ ▼	Enter	CAL-FAIL	<i>Operation: No calibration gas applied, or sensor did not respond correctly.</i>	
		WAIT-300	<i>Operation: Five minute time out before sensor is returned to service.</i>	
M E ▲ ▼	Mode	(Any)	<i>Operation: Hold magnet over Mode Switch for ten seconds to abort calibration</i>	Sub C
			Banner: Calibration Aborted	
		XXXPPM	Default Display	

**Table 5-1
Calibration**

6. SERVICE

6.1 SENSOR MODULE CONFIGURATION

The gas sensor module is comprised of the following sub-assemblies (Figure 6-1):

5100-XX-IT	Gas Sensor Module
SPL21810	Aluminum Enclosure (SPL32178 316SS Enclosure)
SPL21825	Transmitter Assembly
XXXXXXX	Sensor Assembly (See Appendix B)
5200-XX-IT	Sensor (See Appendix B)

6.2 ENCLOSURE REPLACEMENT

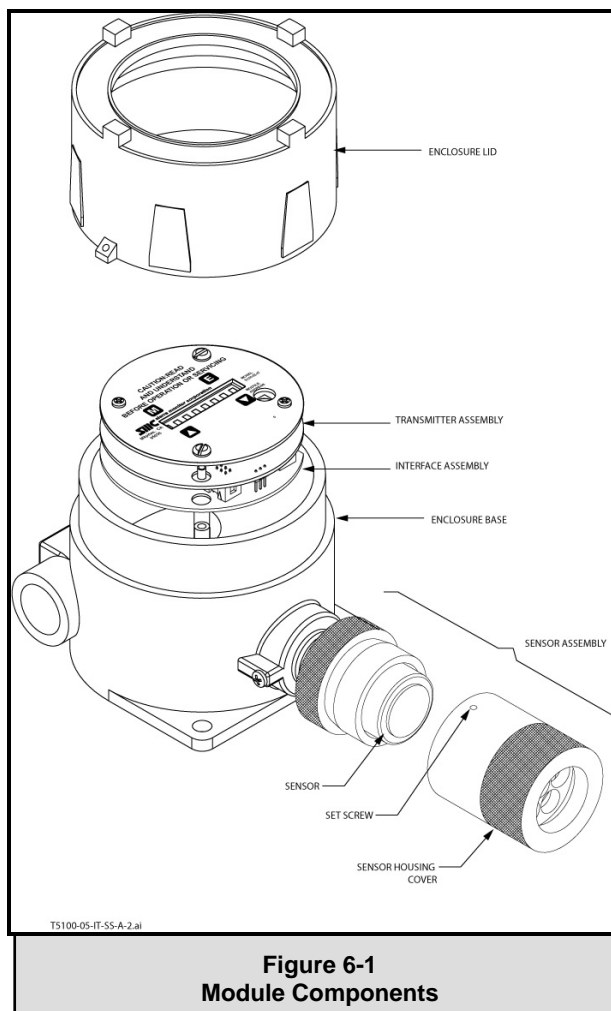

The enclosure should be replaced if the cover threads or conduit threads have been damaged, or if the enclosure has been damaged sufficiently that it no longer meets the required NEMA classification.

To replace the enclosure follow the transmitter and sensor assembly removal instructions, remove the damaged enclosure from its conduit, install a new enclosure and replace the transmitter and sensor assembly.

6.3 TRANSMITTER REPLACEMENT

The transmitter assembly should be replaced when it is determined that it is unreliable, noisy or cannot be adjusted for calibration. This may occur due to age, corrosion or failed components.

To replace the transmitter assembly:

- a. Remove the cover of the main enclosure
- b. Unscrew the two thumb screws in the top of the cover plate, lift the assembly and rotate 90° to relieve the wiring service loop
- c. Unplug the sensor connector from the transmitter
- d. Plug connector into new transmitter (be sure to match numbers between connector and socket).
- e. Restore power and allow a minimum of 3 hours for stabilization before re-calibration

6.4 SENSOR REPLACEMENT

The gas sensor which is located inside the sensor assembly housing can be replaced without replacement of the housing. The gas sensor needs replacement when:

- ◆ The "CAL-FAIL" message appears after calibration
- ◆ The sensor output signal is noisy, causing erroneous gas level readings

To replace the sensor:

- a. Confirm that system power has been removed
- b. Remove the gas sensor module enclosure cover,
- c. Unscrew the two thumb screws in the top of the faceplate, lift the transmitter assembly and rotate 90° to relieve the wiring service loop.
- d. Unplug the sensor connector from the transmitter
- e. Unscrew the old sensor assembly from the enclosure conduit hub. Remove the sensor assembly with its harness
- f. Unscrew sensor housing cover from the sensor (be sure to loosen the set screw first)
- g. Carefully pull the old sensor straight up from the socket
- h. Press the new sensor into the socket.
- i. Reverse the preceding steps to install the sensor assembly.
- j. Allow the new sensor to stabilize for a minimum of 3 hours and then calibrate using the procedure in Section 6.

6.5 INSTALLATION INSPECTION

Prior to system start-up or trouble shooting the entire system should be visually inspected. The following are guidelines for that inspection:

6.5.1.1 CONTROLLER INSTALLATION

- Controller installed in conformance to instruction manual recommendations.
- AC power is correctly grounded.
- Hot AC and relay connections have safety covers installed.

6.5.1.2 SENSOR MODULE INSTALLATION

- Module installation in conformance with this manual.
- Modules accessible for calibration.
- Wiring terminations clean and correct.

6.5.1.3 MOISTURE TRAPS AND RAINSHIELDS

- Conduit seals and drains installed to avoid moisture build up in electronics enclosure. Water accumulation in sensor module enclosures is a major cause of damage and system failures - take precautions to seal electrical conduits and provide moisture traps and drains to avoid water damage
- Rain-shields installed where applicable.

6.5.1.4 STANDARD VOLTAGES

- DC Voltage to be applied to the sensor module must be between 10 VDC and 30 VDC.

6.5.2 INSPECTION AND TROUBLESHOOTING GUIDE

The inspection and troubleshooting guide can be used to step through the system start-up and to determine the corrective action if a fault occurs.

6.5.3 IF MODULE DOES NOT RESPOND TO GAS

1. Repeat calibration procedure.
2. Remove the gas and wait for the timer to completely count down.
3. Apply 50 PPM and verify that the sensor sees 50 PPM gas after calibration.
4. If the sensor still does not see gas, power cycle the unit and repeat calibration.

6.5.4 IF THE MODULE DISPLAYS “STARTING” FOR MORE THAN 1 HOUR

1. Make sure the sensor is placed in an ambient room temperature environment.
2. Power cycle the sensor.
3. Ensure that the sensor is not exposed to the gas of interest during warm-up.

6.5.4.1 IF THE MODULE DOES NOT DISPLAY THE CORRECT PPM

1. Power cycle the unit
2. Recalibrate the sensor.

6.5.4.2 IF THE DISPLAY SHOWS ‘F’

1. Power down the unit
2. Open the enclosure and unplug the sensor assembly from the transmitter board.
3. Plug the sensor back into the transmitter board carefully and ensure a secure fit.
4. Power up the unit.

6.5.4.3 IF THE DISPLAY SHOWS ‘C’

1. Complete calibration and exit to operating mode.

6.5.4.4 IF THE DISPLAY SHOWS ‘S’

1. Check connections with Sentry Connections.

7. APPENDICES

APPENDIX A - SPECIFICATIONS

Sensor type: Electrochemical

	5100-03-IT O2	5100-04-IT CO	5100-05-IT H2S	5100-06-IT Cl2
Max. Range	0-25 %Vol	0-1000 PPM	0-100 PPM	0-10 PPM
User Settings Range		0-100, 0-500, variable	0-10, variable	0-5, variable
Zero Drift	+/- 0.1%	+/- 1 PPM	+/- 0.5 PPM	+/- 0.5 PPM
Repeatability	+/- 0.2%	+/- 1 PPM	+/- 1 PPM	+/- 0.5 PPM
Linearity	+/- 0.2%	+/- 1 PPM	+/- 1 PPM	+/- 0.5 PPM
Resolution	+/- 0.1%	0.5 PPM	0.1 PPM	0.1 PPM
Response Time (1)	<10 sec	<25 sec.	<30 sec.	<60 sec
Accuracy	+/- 0.2%	+/- 1 PPM	+/- 0.5 PPM	+/- 0.5 PPM
Sensor Life	2 years	2 years	2 years	2 years

- (1) Response time to 90% full signal value for applied concentration
- (2) Sensor life typical for use at standard temperature and pressure with occasional exposure to gas of interest

Output:

Display:	Fixed and Scrolling LED
Relays (Optional):	8 Amp, High Alarm, Low Alarm, 2 Amp Trouble all SPDT
Analog Output (Optional)	Analog 4-20 mA (Trouble 0 mA, Calibration 1.5 mA)
Signal Output:	Sentry bus Serial RS-485 Modbus RTU

Input:

Remote Alarm Reset:	Normally open digital input (supervised or non-supervised)
---------------------	--

Electrical Data:

Power consumption:	2 watts
Connection type:	3 wire
Input voltage:	24 VDC nominal: 10-30VDC

Operating Range:

	5100-03-IT O2	5100-04-IT CO	5100-05-IT H2S	5100-06-IT Cl2
Ambient Temp (°F)	5 to 122 °F	-4 to 122 °F	-40 to 122 °F	-4 to 122 °F
Ambient Temp (°C)	-15 to 50 °C	-20 to 50 °C	-40 to 50 °C	-20 to 50 °C
Relative Humidity	5 – 99%	5 – 99%	5 – 99%	5 – 99%

Enclosure:

Material - Standard:	Polyester powder-coated, sand-cast, copper-free aluminum
Material - Stainless Steel Option	316 Stainless Steel (FM approval pending)
Dimensions: (H x W x D)	7.5 x 5.0 x 4.8 inches Al, 7.5 x 5.0 x 4.4 inches SS (21.6 x 12.7 x 12.2 cm)
Weight:	2.7 lb. (1.3 Kg) (standard Aluminum enclosure) 5.4 lb. (2.6 Kg) 316 Stainless Steel
Housing:	NEMA 4X

Electrical Classification

Performance:	Explosion proof, Class 1, Div. I, Groups B, C, D Class I, Zone 1, groups IIB+H2 IP66
--------------	---

Approvals:

FM Approved	Performance and Safety Approval Pending
-------------	---

Modbus:

Baud:	38400 (Adjustable 2400 to 38400 Baud)
Parity:	None
Stop bit:	1
Data bits:	8
Flow Control:	None
Memory map:	Appendix E

Warranty: Limited Warranty 2 years
 Specifications subject to change without notice



Ordering Information:

5100	-	XX	-	IT	-	YY	-	ZZ
- 5100 Series								
- 03 = O ₂								
- 04 = CO		- IT Series						
- 05 = H ₂ S				- AI (Aluminum Enclosure)		- 01= Sentry, RS-485, 4-20mA, & Digital Input		
- 06 = Cl ₂				- SS (Stainless Steel)		- 02= Sentry, RS-485, 4-20mA, Digital Input & Relays		

APPENDIX B: - MODEL NUMBERS & PARTS LIST**Sensor Module**

5100-03-IT	Gas Sensor Module, Oxygen
5100-03-IT-SS	Gas Sensor Module, Oxygen, Stainless Steel Enclosure
5100-04-IT	Gas Sensor Module, Carbon Monoxide
5100-04-IT-SS	Gas Sensor Module, Carbon Monoxide, Stainless Steel Enclosure
5100-05-IT	Gas Sensor Module, Hydrogen Sulfide
5100-05-IT-SS	Gas Sensor Module, Hydrogen Sulfide, Stainless Steel Enclosure
5100-06-IT	Gas Sensor Module, Chlorine
5100-06-IT-SS	Gas Sensor Module, Chlorine, Stainless Steel Enclosure

Options

5394-52	Remote Sensor/Display Option
5311-00	Rainshield

Calibration Items

1250-01	Gas Sensor Calibration Kit, Type A (O ₂ , CO, H ₂ S)
1250-03	Gas Sensor Calibration Kit, Type C (Cl ₂)
1260-00	Gas Cylinder, Air, (Type A) , 105 litres
1260-04	Gas Cylinder, CO 100 PPM, (Type A) 57 litres
1260-05	Gas Cylinder, H ₂ S in N ₂ , 25 PPM, (Type A) 57 litres
1260-06	Gas Cylinder, Cl ₂ , 5 PPM, (Type C) 104 litres
1260-13	Gas Cylinder, CO, 1000 PPM, (Type A), 105 liters
5360-00	Calibrator Head Standard
1256-01	Regulator Type A Calibrator
1265-03	Regulator Type C Calibrator
5358-01	Calibration Adapter - Direct, Standard
5358-50	Calibration/Configuration Magnetic Tool

Spare Parts

5200-03-IT	Sensor, for 5100-03-IT
5200-04-IT	Sensor, for 5100-04-IT
5200-05-IT	Sensor, for 5100-05-IT
5200-06-IT	Sensor, for 5100-06-IT
SPL21834	Sensor Assembly, Aluminum, for 5100-03-IT
SPL21832	Sensor Assembly, Aluminum, for 5100-04-IT
SPL21830	Sensor Assembly, Aluminum, for 5100-05-IT
SPL21833	Sensor Assembly, Aluminum, for 5100-06-IT
SPM27082	Sensor Assembly, 316SS, for 5100-03-IT
SPM27083	Sensor Assembly, 316SS, for 5100-04-IT
SPM27079	Sensor Assembly, 316SS, for 5100-05-IT
SPM27084	Sensor Assembly, 316SS, for 5100-06-IT
SPL21824	Transmitter
SPL21810	Enclosure, Transmitter, Aluminum
SPL21825	Enclosure Transmitter, 316SS
SPL21825	Interface Board with Relay
SPL27826	Interface Board without Relay

APPENDIX C: LIMITED WARRANTY

SIERRA MONITOR CORPORATION warrants its products to be free from defects in workmanship or material under normal use and service for two years after date of shipment. SMC will repair or replace without charge any equipment found to be defective during the warranty period. Final determination of the nature and responsibility for defective or damaged equipment will be made by SMC personnel.

All warranties hereunder are contingent upon proper use in the application for which the product was intended and do not cover products which have been modified or repaired without SMC approval or which have been subjected to accident, improper maintenance, installation or application, or on which original identification marks have been removed or altered. This Limited Warranty also will not apply to interconnecting cables or wires, consumables (ie. calibration gases, batteries, sensors), nor to any damage resulting from battery leakage.

In all cases SMC's responsibility and liability under this warranty shall be limited to the cost of the equipment. The purchaser must obtain shipping instructions for the prepaid return of any item under this warranty provision and compliance with such instruction shall be a condition of this warranty.

Except for the express warranty stated above, SMC disclaims all warranties with regard to the products sold hereunder including all implied warranties of merchantability and fitness and the express warranties stated herein are in lieu of all obligations or liabilities on the part of SMC for damages including, but not limited to, consequential damages arising out of/or in connection with the use or performance of the product.

APPENDIX E: MODBUS MEMORY MAP
Read Register Table

Register	Description	Comments
40001	Concentration	Gas Concentration multiplied by 100
40002	Temperature	Temperature in degrees Celsius scaled by a factor of 100
40003	High Alarm Relay	Boolean indicating the High Alarm Status, 0 No Alarm, 1 High Alarm
40004	Low Alarm Relay	Boolean indicating the Low Alarm Status, 0 No Alarm, 1 Low Alarm
40005	Low Alarm Value	Low alarm set point, used for activating Alarms
40006	High Alarm Value	High alarm set point, used for activating High Alarms
40007	Reserved	
40008	Reserved	
40009	Reserved	
40010	Reserved	
40011	Trouble Bits	0 for no trouble
40012	Trouble	1 for any trouble, 0 for no trouble
40013	High Alarm Immediate	Like 40003. but never latched
40014	Low Alarm Immediate	Like 40004, but never latched
40015	Random ID	Randomly generated permanent ID of sensor
40016	Restart Count	
40017	Run time – high	In minutes
40018	Run time – low	In minutes
40019	Max. gas value	*scale ((see 40024)
40020	Model	51005, 51003, 51004, 51006, etc
40021	Range	*scale (see 40024)
40022	Units	3 is PPM
40023	Temperature Units	0 is C, 1 is F
40024	Gas Scale	Value like 1 or 100
40025	Temperature Scale	Value like 1 or 100

Free Manuals Download Website

<http://myh66.com>

<http://usermanuals.us>

<http://www.somanuals.com>

<http://www.4manuals.cc>

<http://www.manual-lib.com>

<http://www.404manual.com>

<http://www.luxmanual.com>

<http://aubethermostatmanual.com>

Golf course search by state

<http://golfingnear.com>

Email search by domain

<http://emailbydomain.com>

Auto manuals search

<http://auto.somanuals.com>

TV manuals search

<http://tv.somanuals.com>