



Owner's Manual

AMC550mp

Snell



SPECIFICATIONS

Frequency Response ($\pm 3\text{dB}$)	80Hz–20kHz
Recommended Amplifier Power	15–150 watts
Nominal Impedance	8 ohms
Sensitivity (2.83v at 1m)	85dB SPL
High Frequency Drivers	Two 2 $\frac{1}{2}$ -inch (65mm) polymer treated cones
Bass Unit	5 $\frac{1}{4}$ -inch (135mm) copolymer cone with butyl rubber surround
Crossover Frequency	900Hz
Grille	Perforated metal, painted white
Dimensions (H x W x D)	8 $\frac{1}{4}$ x 15 $\frac{1}{8}$ x 3 $\frac{1}{4}$ inches (210 x 384 x 64mm)
Rough Opening Requirements (H x W x D)	7 $\frac{1}{2}$ x 14 $\frac{1}{8}$ x 3 $\frac{3}{4}$ inches (190 x 358 x 95mm)
Shipping Weight / Pair	14 lbs. (6.4 Kg)
Finish	Matte white, suitable for painting

PRODUCT DESCRIPTION

By providing the choice of diffuse field or direct field response, and the means to easily switch between them, the AMC550mp offers the ideal performance for today's surround applications. Furthermore, this unique two-way system mounts flush with the wall surface and virtually disappears in the listening room. In addition to its superb surround performance, its excellent performance as a direct radiator makes it equally suitable for front channel use.

Inside the AMC550mp are two subenclosed 2 1/2" (65mm) high frequency drivers. One fires forward, the other rearward. Frequencies below 900Hz are handled by a 5 1/4" (135mm) driver with butyl rubber surround. Gold-plated five-way binding posts allow quick connection to virtually any speaker cable.

The front surface has a matte white finish, suitable for use in a variety of environments. For a

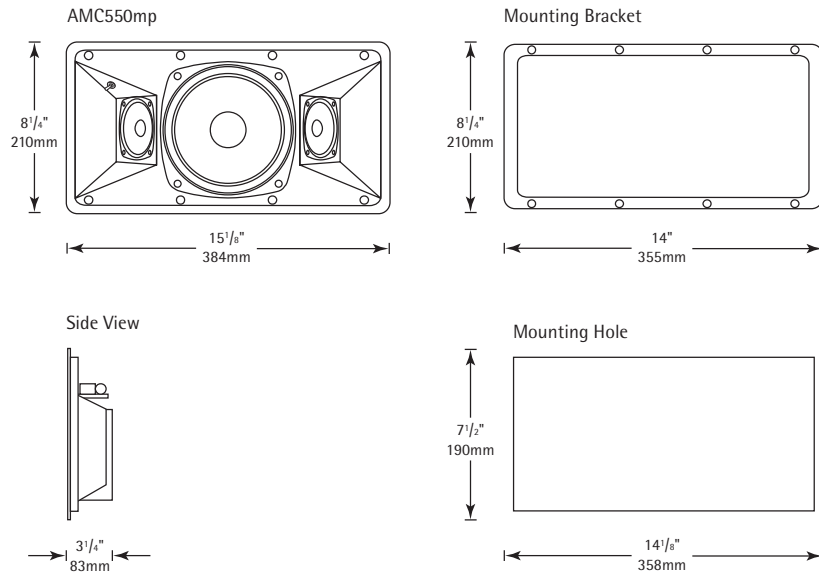

perfect custom finish, the grille may be painted using the supplied paint mask.

INSTALLATION INSTRUCTIONS

IMPORTANT: This manual assumes the installer possesses skill in the proper use of hand and power tools, knowledge of local building and fire codes, and a familiarity with the environment behind the wall or ceiling in which the speakers will be installed.

Examine the contents of the shipping carton and verify it contains the following:

- Model AMC550mp Loudspeaker
- Mounting Bracket
- Painting Mask
- Metal Grille
- Template
- Owner's Manual

PAINTING THE SPEAKERS

If you intend to paint the speakers, it is best to do so before installation

1. Remove the speaker grille by carefully prying each corner with an awl or small screwdriver.

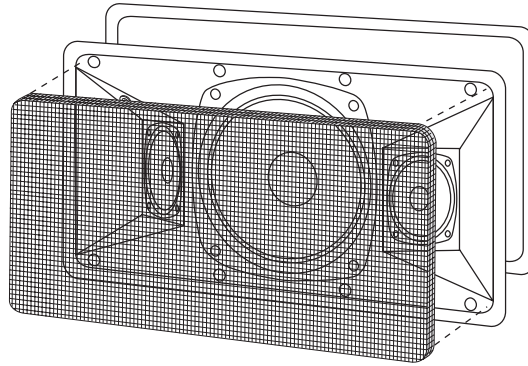

2. Place a strip of wide masking tape over each of the holes in the paint shield. Place the paint shield on the front of the speaker and press on the tape to hold it in position on the front of the speaker baffle.

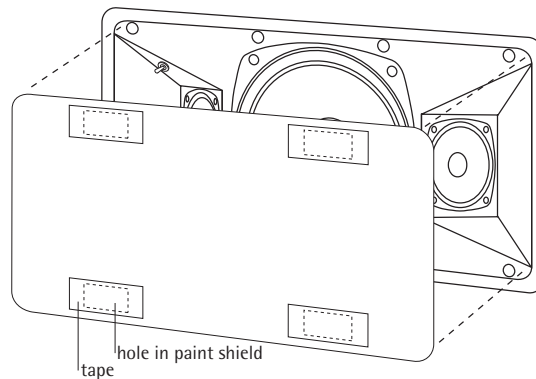

3. After painting carefully remove the paint shield.

HOW TO PLACE YOUR AMC550mp's

Determining Room Placement

Whether you prefer the enveloping sense of a diffusion-oriented surround speaker, or a more "direct" surround effect, proper placement of your AMC550mp's will enable you to achieve it. Using the following guidelines will help you get the most from your speakers. Every room is different, so there are no hard and fast rules for placement. Don't be afraid to experiment. A few minutes spent working on determining the best place for your speakers will help ensure they sound their best.

Height

Place the AMC550mp's at least 5 feet (1.5m) from a floor, yet 12 inches (30cm) from the ceiling. A fairly high mounting location will aid in sound diffusion and reduce the chance you will be able to audibly locate the speakers. Increased height will also help to even out the sound levels across the listening area.

Boundaries

Keep the AMC550mp's at least 12 inches (30cm) away from an adjacent wall or large obstacle.

Coverage Area

For large areas, multiple AMC550mp's can be used to ensure even coverage. Use one pair of AMC550mp's for every three rows of seats (approximately 10 feet between the speakers).

Placement

Please consult the placement diagram. To achieve the greatest sense of sound envelopment, place the AMC550mp's to the side of the listening area. If the listening area is against a wall (for example, if your couch is placed against a back wall), place the AMC550mp's to the side of the couch, leaving at least 12 inches (30cm) between the AMC550mp's and the back wall.

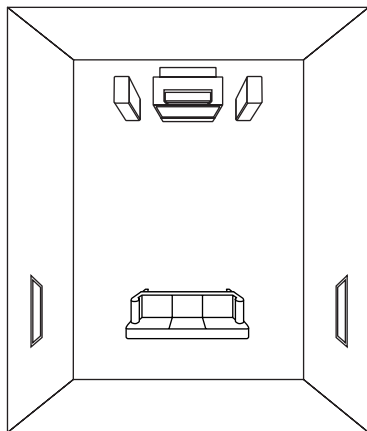

Conventional Room Layout

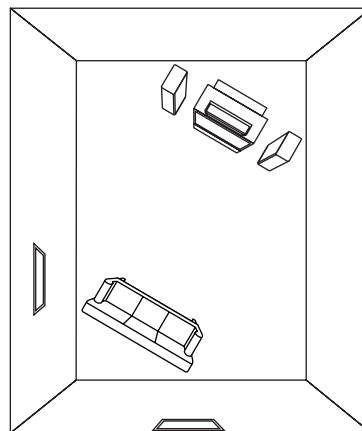

Alternative Room Layout



Back Wall Placement

When placing the AMC550mp's behind your listening area, keep them as close to the side walls as possible – but no closer than 12 inches (30cm).

Diffuse/Direct Surround Mode Patterns

Diffuse Setting

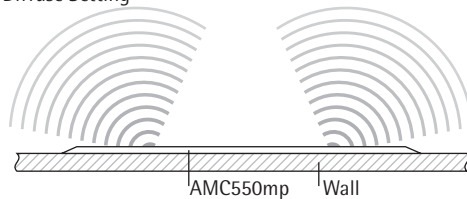

Direct Setting

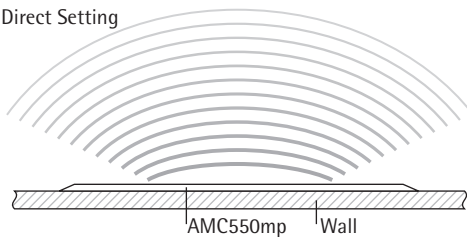

When the surround mode switch under the grille is set to "Diffuse", the AMC550mp produces the sound radiation pattern shown in the upper diagram. The speaker will radiate energy in all directions except perpendicular to the mounting plane. Listeners in this area will primarily hear sound that is reflected off of other surfaces in the room. This gives the system a diffuse, hard to localize effect that can be very good for surround applications.

Setting the switch to "Direct" makes the AMC550mp produce the sound radiation shown in the lower illustration. The sound energy is strongest directly in front of the speaker. The direct setting will draw your attention toward the speaker and produce more dramatic "off-screen pans". See the following section for more details.

Special Note For Use As Front Channel Speakers

If you are planning on using the AMC550mp's as wide coverage front channel speakers, use only the "Direct" setting, and place them as near to seated ear level as is practical.





AMC550mp OPERATION AND USE

One of the best features of the AMC550mp is that it can be switched between "Direct" and "Diffuse" radiation modes. The surround mode switch is conveniently located under the grille to allow easy access. See Diagram for toggle switch location. Refer to the switch diagram and the figures to determine the appropriate setting. You should take some time and experiment to best adapt the speaker to your listening habits.

The diffuse mode is preferable when the listener should not be able to localize the sound source. This should be perceived as "wall-of-sound". Music with side channels encoded with hall effects will produce a feeling of envelopment. Surround encoded baseball games will be heard as if the stadium were all around, with no clear source of off-the-field, realism-enhancing effects.

Both music and movies will have instances when either "direct" or "diffuse" surround sound will suit. Music recordings with musicians in the side channels will most likely sound best in "direct" mode. However, if the side channels are used to record the performance environment or audience sounds, the "diffuse" mode may be best.

Similarly, with movie soundtracks, some producers will use side channels to pan discrete sources off screen (e.g., jet fly-bys, etc.). This material will be well-served with the "direct" mode. Other movies will use the side channels to transport you to a remote environment with street noises, crowd noises, etc. These may be best reproduced in "diffuse" mode.

PREPARING FOR INSTALLATION

Preparing for Installation

Map out the wiring paths from the speakers to the amplifier. We recommend 16-gauge wire for runs up to 25 feet, and 14-gauge or thicker for longer runs. Be sure the speaker wire does not rest or rub against any sharp or pointed objects.

The speakers should be mounted on a flat surface to form a good seal between the speaker flange and the mounting surface.

Each speaker is 8 ohms nominal. When connecting more than two speakers per amplifier channel, you should use series/parallel wiring or line transformers. In all cases, make certain that the total impedance does not fall below the amplifier's minimum rating. If you are not sure, contact your Snell Acoustics dealer.

You Will Need

1. A utility knife, an electric jigsaw, or another means of cutting a hole in the mounting surface.
2. Phillips screwdriver.
3. A wire cutter or stripper for preparing the speaker wires.
4. An awl or a small screwdriver to remove the speaker grille.

With the hardware supplied, the speaker can be installed in existing walls and ceilings from 1/2" (12mm) to 1 1/2" (38mm) thick. For thinner walls, you will need to use spacers (not provided) for the mounting bracket. In walls greater than 1 1/2" (38mm) thick, you will need longer screws.

Installation

1. Make a cutout using the supplied template.



2. Run the wire from the amplifier to the cutout. Allow an extra foot of wire at the cutout. Strip 1/2" (12mm) off the wire, and tightly twist the wire strands together.
3. Remove speaker grille by carefully prying each corner with an awl or a small screwdriver.
4. Prepare the speaker/bracket assembly for installation as shown.

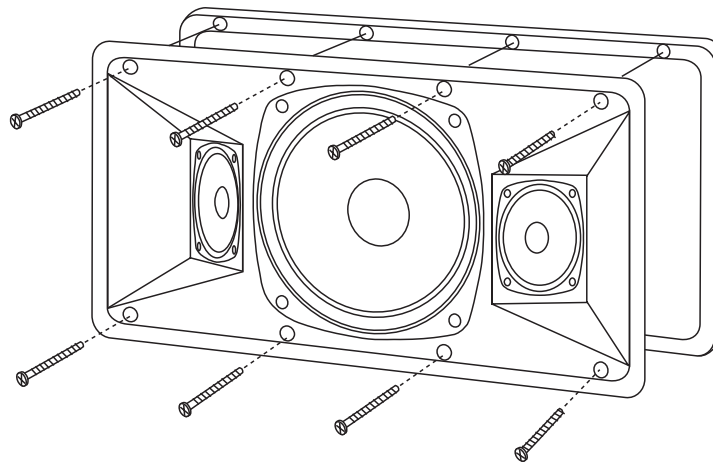



Note: The AMC550mp is sold in mirror-imaged pairs. On the back of each system is a label that specifies the screen direction. In the diffuse mode, the response will be slightly superior in this direction. Install the two systems so that the arrows point toward the screen. If listeners are not going to be located on or near the center axis of the speaker, the speaker should be oriented with the arrow toward the listener location (even if this is away from the screen).

Warning: To prevent electrical shock, always switch off the amplifier or receiver when making connections to the speaker.

Important: Typically, one side of the wire is smooth. Connect this side to the - (black) speaker terminal. The other side has a rib or stripe. Connect this to the + (red) speaker terminal. Connect wire at the amplifier in the same way. Failure to do so will result in degraded sound.

5. Install speaker according to diagram below.

Important: Do not overtighten screws. Doing so will break the frame and/or make it impossible to insert the grille.

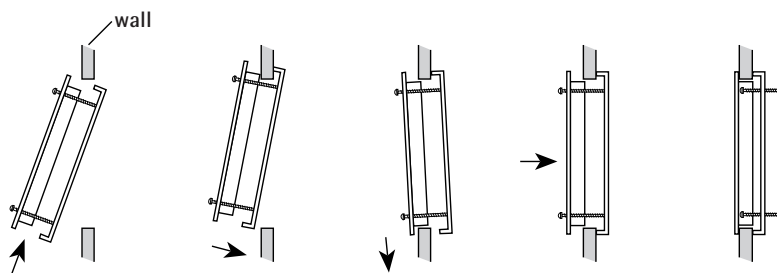
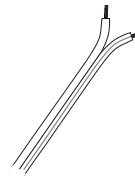

LISTENING LEVELS AND POWER HANDLING

- *The power recommendation for the system assumes you will operate the amplifier in a way that will not produce distortion. All speakers can be damaged by even a modest amplifier if it is producing distortion. If you hear a gritty noise or other signs of strain, turn down the volume. Prolonged or repeated operation of your speakers with a distorted signal can cause damage that is not covered by the warranty. It is especially important that you do not overdrive the bass capability of smaller speakers. Watch for noises, such as pops, caused by the music's bass line. Use of the loudness control and/or full bass boost at louder volumes is likely to overdrive the woofer. Use such controls sparingly.*





HOW TO CARE FOR YOUR SPEAKERS

- ▶ *Use a soft terry cloth towel slightly dampened with water, glass cleaner, or a diluted mild detergent. The towel should be just damp enough to wipe the surface clean without leaving a trail of moisture.*
- ▶ *Do not use abrasive cleaners or any cleaner containing chemicals harsher than those found in glass cleaner.*

LIMITED WARRANTY

For five years from the date of purchase, Snell Acoustics will repair for the original owner any defect in materials or workmanship that occurs in normal use of the speaker system, without charge for parts and labor.

Your responsibilities are to use the product according to the instructions supplied, to provide safe and secure transportation to an authorized Snell Acoustics service representative, and to present proof of purchase from an authorized Snell dealer in the form of your sales slip when requesting service.

Excluded from this warranty is damage that results from abuse, misuse, accidents, shipping, repairs, or modifications by anyone other than an authorized Snell Acoustics service representative. This warranty is void if the serial number has been removed or defaced.

This warranty gives you specific legal rights, and you may also have other rights that vary from state to state.

If Service Seems Necessary

Contact the dealer from whom you purchased the speaker system. If that is not possible, call us at 978-538-6262, or write to: Snell Acoustics
300 Jubilee Drive, PO Box 3717
Peabody, MA 01960

We will promptly advise you of what action to take. If it is necessary to return your speaker system to the factory, please ship it prepaid in the original factory packaging. Please note that Snell Acoustics will not be held liable for shipping damage due to improper packaging. After it has been repaired, we will return it freight-prepaid in the U.S. or Canada.







©2005 Snell Acoustics. All Rights Reserved.
Specifications are subject to change without notice.
Covered by patents issued and/or pending.
Part #542-1015

Snell

300 Jubilee Drive, PO Box 3717
Peabody, MA 01961-3717
phone: 978-538-6262
fax: 978-538-6266
email: info@snellacoustics.com
www.snellacoustics.com



Free Manuals Download Website

<http://myh66.com>

<http://usermanuals.us>

<http://www.somanuals.com>

<http://www.4manuals.cc>

<http://www.manual-lib.com>

<http://www.404manual.com>

<http://www.luxmanual.com>

<http://aubethermostatmanual.com>

Golf course search by state

<http://golfingnear.com>

Email search by domain

<http://emailbydomain.com>

Auto manuals search

<http://auto.somanuals.com>

TV manuals search

<http://tv.somanuals.com>