



# SDD Digital Dosing Units

Part Number: 882.00276.00  
Bulletin Number: BF3-600  
Effective: 12/01/05

Write Down Your Serial Numbers Here For Future Reference:

_____	_____
_____	_____
_____	_____

We are committed to a continuing program of product improvement. Specifications, appearance, and dimensions described in this manual are subject to change without notice.

DCN No. \_\_\_\_\_

© Copyright 2005

All rights reserved.

## Please note that our address and phone information has changed. Please reference this page for updated contact information.



These manuals are obsolete and are provided only for their technical information, data and capacities. Portions of these manuals detailing procedures or precautions in the operation, inspection, maintenance and repair of the products may be inadequate, inaccurate, and/or incomplete and shouldn't be relied upon. Please contact the ACS Group for more current information about these manuals and their warnings and precautions.

### Parts and Service Department

The ACS Customer Service Group will provide your company with genuine OEM quality parts manufactured to engineering design specifications, which will maximize your equipment's performance and efficiency. To assist in expediting your phone or fax order, please have the model and serial number of your unit when you contact us. A customer replacement parts list is included in this manual for your convenience. ACS welcomes inquiries on all your parts needs and is dedicated to providing excellent customer service.

#### For immediate assistance, please contact:

- North, Central and South America, 8am – 5pm CST +1 (800) 483-3919 for drying, conveying, heating and cooling and automation. For size reduction: +1 (800) 229-2919.  
North America, emergencies after 5pm CST (847) 439-5855  
**North America email: [acsuscanadacustserv@corpemail.com](mailto:acsuscanadacustserv@corpemail.com)**
- Mexico, Central & South America  
**Email: [acslatinamericacustserv@corpemail.com](mailto:acslatinamericacustserv@corpemail.com)**
- Europe, Middle East & Africa +48 22 390 9720  
**Email: [acseuropecustserv@corpemail.com](mailto:acseuropecustserv@corpemail.com)**
- India +91 21 35329112  
**Email: [acsindiacustserv@corpemail.com](mailto:acsindiacustserv@corpemail.com)**
- Asia/Australia +86 512 8717 1919  
**Email: [acsasiacustserv@corpemail.com](mailto:acsasiacustserv@corpemail.com)**

### Sales and Contracting Department

Our products are sold by a worldwide network of independent sales representatives. Contact our Sales Department for the name of the sales representative nearest you.

Let us install your system. The Contract Department offers any or all of these services: project planning; system packages including drawings; equipment, labor, and construction materials; and union or non-union installations.

#### For assistance with your sales or system contracting needs please Call:

North, Central and South America +1 (262) 641-8600 or +1 (847) 273-7700 Monday–Friday, 8am–5pm CST

Europe/Middle East/Africa +48 22 390 9720

India +91 21 35329112

Asia/Australia +86 512 8717 1919

#### Facilities:

ACS offers facilities around the world to service you no matter where you are located. For more information, please visit us at [www.acscorporate.com](http://www.acscorporate.com)

United States:

#### ACS Schaumburg – Corporate Offices

1100 E. Woodfield Road  
Suite 588  
Schaumburg, IL 60173  
Phone: + 1 847 273 7700  
Fax: + 1 847 273 7804

#### ACS New Berlin – Manufacturing Facility

2900 S. 160<sup>th</sup> Street  
New Berlin, WI 53151  
Phone : +1 262 641 8600  
Fax: + 1 262 641 8653

Asia/Australia:

#### ACS Suzhou

109 Xingpu Road SIP  
Suzhou, China 215126  
Phone: + 86 8717 1919  
Fax: +86 512 8717 1916

Europe/Middle East/Africa:

#### ACS Warsaw

Ul. Działkowa 115  
02-234 Warszawa  
Phone: + 48 22 390 9720  
Fax: +48 22 390 9724

India

#### ACS India

Gat No. 191/1, Sandbhor Complex  
Mhalunge, Chakan, Tal Khed,  
Dist. Pune 410501, India  
Phone: +91 21 35329112  
Fax: + 91 20 40147576

# **Table of Contents**

<b>SECTION 1: INTRODUCTION .....</b>	<b>3</b>
1.1 Controller.....	4
1.2 Keys and Symbols.....	6
<b>SECTION 2: QUICK START-UP.....</b>	<b>8</b>
<b>SECTION 3: INITIAL INSTALLATION AND OPERATION.....</b>	<b>11</b>
3.1 Initial Installation.....	11
3.2 Initial Operation.....	13
3.3 Injection Molding.....	14
3.4 Extrusion Constant.....	19
3.5 Extrusion Proportional.....	22
3.6 Calibration.....	26
<b>SECTION 4: ADVANCED OPERATIONS/CONTROL FUNCTIONS.....</b>	<b>29</b>
4.1 Recipe Storage/Recall.....	29
4.2 Clearing the Totalizer .....	31
4.3 Acknowledging Alarms .....	31
4.4 Optional Equipment.....	31
<b>SECTION 5: MAINTENANCE.....</b>	<b>34</b>
5.1 Maintenance Intervals.....	34
5.2 Removing the Scraper.....	34
5.3 Cleaning the DD Dosing Station.....	35
5.4 Changing the Dosing Disc in the DT Dosing Station .....	37
5.5 Removing/Replacing the Scraper in the DT Dosing Station .....	38
5.6 Cleaning the DT Dosing Station .....	39
5.7 Exchangeable Stations .....	40
5.8 Exchanging Fuses .....	40
<b>APPENDIX A: TROUBLESHOOTING.....</b>	<b>42</b>
A.1 General Troubleshooting.....	42
A.2 Malfunctions or Errors—Error Codes.....	42
A.3 Determining the Software Setup Factor.....	44
A.4 Recipe Formulas .....	44
<b>APPENDIX B: BASIC PARAMETER SETTINGS.....</b>	<b>46</b>
<b>APPENDIX C: DISC DOSING FACTORS AND EQUIPMENT DRAWINGS AND PARTS NUMBERS.....</b>	<b>53</b>
<b>APPENDIX D: SPARE PARTS LIST.....</b>	<b>62</b>

## **Section 1: Introduction**

This User's Manual is intended for use with the Digital Dosing Additive Feeder. The feeder precisely meters and controls the addition of master batches, chemical additives, and regrinds to primary plastics. The Digital Dosing unit can meter both powder and granular material of various sizes. It can be used on both extrusion and injection molding machines. Depending on the application and throughput, two models are available: 1 Station Digital Dosing Unit or 2 Station Digital Dosing Unit. See Figures 1 and 2. This manual covers the operation of both units.



*Figure 1. 1 Station Digital Dosing Unit*



*Figure 2. 2 Station Digital Dosing Unit*

## 1.1 Controller

The Digital Dosing additive feeder consists of a controller, dosing motor, and feeder(s). The controller is used to

- Enter, recall, and run recipes
- To run, monitor, and stop the dosing process
- To calibrate
- To troubleshoot problems via error codes
- To configure the unit to the desired process.

A touch keypad (see Figure 3) is used to enter or change data.

- The Control system is switched on by means of the On/Off switch (switch set in position "1"). (A)
- The control system is operated via the keyboard. (B)
- The individual operating modes are indicated by Symbols. (C)
- Messages appear on a 5-digit display. Up to ten recipes can be saved and read on request. Recipes can be assigned respective numbers. (D)

**Figure 3: Touch Keypad**

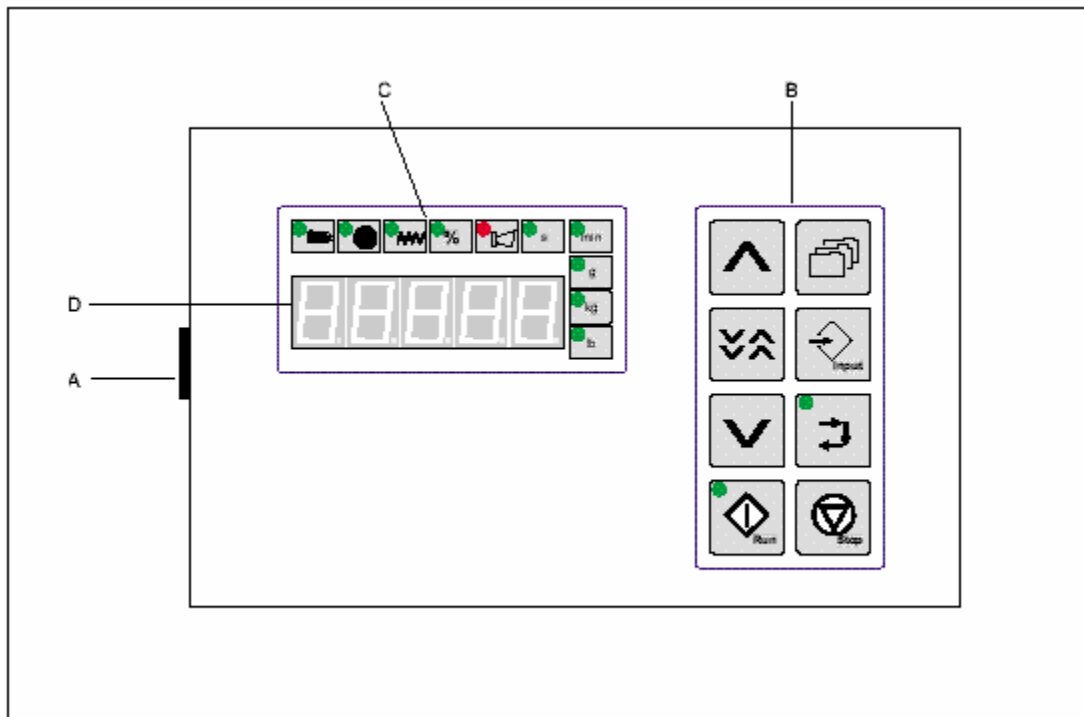

## 1.2 Keys and Symbols



**Recipe Storage/Recall:** For saving, recalling or modifying recipes.



**Stop:** Stops the continuous operation of the feeder. Will reset the totalizer showing metered amount of additive to zero if depressed for two seconds.



**Up-arrow:** For increasing the set value in decimal increments.



**Down-arrow:** For decreasing the set value in decimal increments.



**Arrow Key:** For fast increasing/decreasing of the set value in larger increments. Must be pressed simultaneously with the up- or down-arrow.



**Run:** Starts the continuous operation (LED is lit up) or calibration mode (the LED flashes)

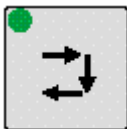

**Calibration Key:** Switches from operation to calibration mode. LED flashes when calibration process has started.

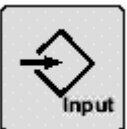

**Input:** Selects the next screen for the input of program parameters.

## Symbols

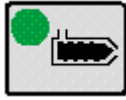

Lights when the run signal from the process machine is received by the Digital Dosing controller.

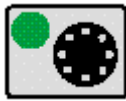

During operation, lights when the disc is dosing material. During calibration and recipe input/viewing, lights when a calibration weight is input or viewed.



(EXTRUSION ONLY) Lights when a screw speed signal is received from the extruder during proportional extrusion



Lights when an alarm occurs.

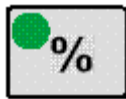

Percent additive



Kilograms



Grams



Pounds



Minutes



Seconds



## Section 2: Quick Start-up

*Quick Start is intended to help you in starting up your Digital Dosing feeder quickly and easily. Please refer to the manual to go into greater detail.*

### **Unpacking:**



1. Unpack box, making sure all parts indicated on packing list are included.
2. Check all parts and equipment for any damage sustained during shipment.
3. If any damage is noted, contact manufacturer for replacement or service.
4. Make sure the following are present before proceeding:
  - Power source 110V/220V
  - Proper mounting flange adapter for the feed throat
  - Dry (ZERO VOLTAGE) contact that closes during screw recovery of IMM
  - Gram scale to measure weight of additive material

### **Mounting:**



2. Mount the complete unit, including dosing hopper full of material, on the feed throat (may need an adapter for feed throat).
3. Identify the motor drive connector (Amp connector-black) and connect to motor.
4. Identify the communication cable (DB9 plug-silver) and connect to DB9 connector under motor drive assembly.
5. Identify power cord (110V) and plug into outlet.
6. **INJECTION MOLDING:** Identify the cycle/run cable (2-conductor cable-gray) for connection to a dry (ZERO VOLTAGE) contact that closes during screw recovery cycle of IMM.
7. **EXTRUSION:** Identify the input cable (2-conductor cable-gray) for connection to 0-10Vdc or 0-20mA signal that indicates rpm of extruder.

### **Recipe Setup For Injection Molding:**

1. Turn power switch to ON position.
2. Press Input to  display #1, "Additive %". Using arrow keys, set additive ratio.

3. Press Input  to display #2, "Shot size of current mold". Using arrow keys, set the total shot size (parts and runners) of the current mold capacity in grams.
4. Press  Input to display #3, "Screw recovery time". Using arrow keys, set the screw recovery time (in seconds). For Extrusion Constant operation, skip this step!
5. Press Input to display #4, "Calibration weight for additive". Enter '0' and proceed to calibration mode below for calibration of additive material.





### Recipe Setup For Extrusion:

1. Turn power switch to ON position.
2. Press  Input to display #1, "Additive %". Using arrow keys, set additive ratio.
3. Press  Input to display #2, "Throughput of extruder". Using arrow keys, set the total extruder throughput in g/min or lb/min.
4. Press  Input to display #3, "Extruder screw speed". Using arrow keys, set the extruder screw speed RPM expected during production.

**NOTE: for Extrusion Constant operation, this step will be skipped.**

5. Press Input to display #4, "Calibration weight for additive". Enter '0' and proceed to calibration mode below for calibration of additive material.

### Calibration:

1. Press "Calibration"  button to start this procedure. Display will show - -  
- -
2. Place the plastic calibration cup on the scale and tare so that the weight of the cup (approx. 24gr.) is not calculated in the calibration procedure.
3. Remove cover of the calibration box, secured by two 5mm Allen screws, under the dosing disc assembly and insert plastic cup provided in top of dosing hopper.
4. Press  "Run" and the dosing disc turns 1/4 turn. This fills all pockets of dosing disc. Dump the dosed material back into the dosing hopper without weighing and replace plastic cup in calibration box.
5. Press  "Run" and the dosing disc turns 1 complete revolution. Remove the calibration cup with the material and place on the gram scale. Enter the weight on the scale into the controller  using the arrow keys. Empty and replace calibration cup.

6. Repeat step #19 four more times, each time entering the new weight from the scale into the controller using the arrow keys. Sometimes the values won't change, or sometimes they may only change by a few tenths of a gram. The controller keeps a running average of all calibration weights entered.
7. After all five samples have been completed; press "calibration" once more and this will save the calibration weight of the material to the recipe. The calibration light will go out and the screen will now show the total amount of additive dosed. The Digital Dosing feeder is now ready to begin operation.
8. Please refer to "Operation Manual" for all supplementary information regarding general operation, cleaning/maintenance, and troubleshooting.
9. Make sure that there is a virgin material supply setup to begin processing. If you do not have a loader or hopper for the virgin material, or if any of the above procedures did not work properly, please contact **the manufacturer in Wood Dale, IL for sales and technical support @ (800) 423-3183 (8am-5pm) CST.**

## **Section 3: Initial Installation And Operation**

### **3.1 Initial Installation**

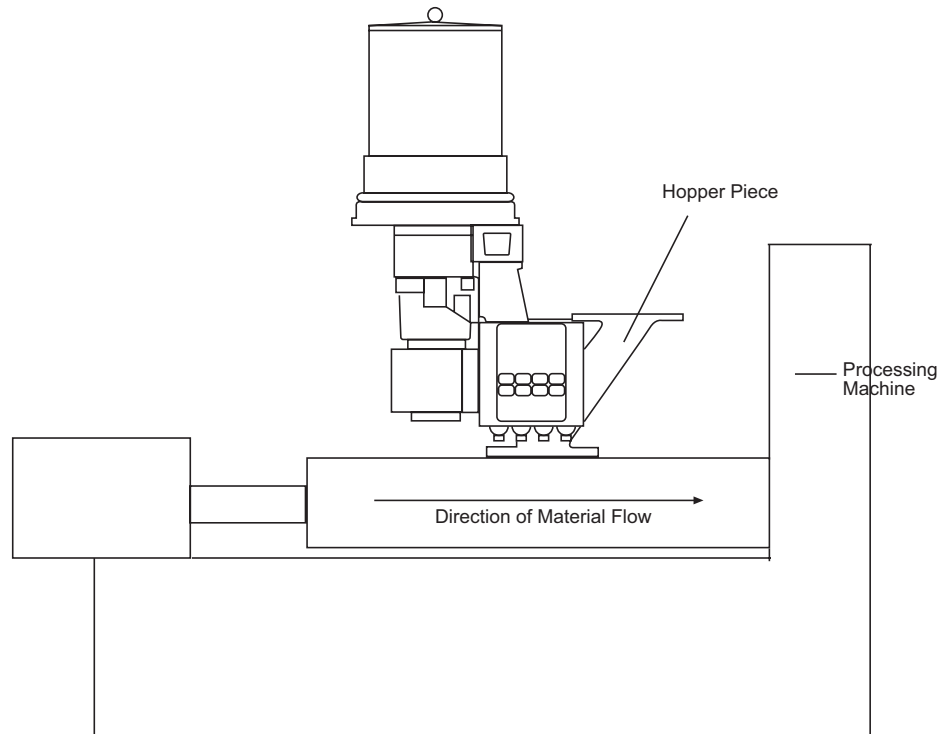

***Figure 4. Digital Dosing Unit Assembly***

1. The Digital Dosing additive feeder is not affected by machine vibration, therefore best performance is achieved by mounting the unit directly to the feed throat of the molding machine or extruder (see Figure 4). The inlet into the process machine must be greater than 2" diameter; otherwise, an adapter might be necessary. If an adapter is necessary, it must be designed so that there are no edges where material can be trapped. The adapter must be smooth to promote even material flow. Consult Sterling for any special requirements.
2. Optimum mounting of the Digital Dosing feeder is shown in Figure 5, with the additive being dosed on the first screw flights.
3. The controller can be mounted on either side of the blender base to optimize operator interface. An optional remote mounting kit for the controller is available from the manufacturer to relocate the controller closer to the operator. The control unit must not

be exposed to extreme heat (maximum temperature 45°C or 115°F) or excessive moisture.

4. Electrical connection to process machine:

- **Injection Molding:** Connect the cycle/run slave cable (thin two-conductor cable) to a set of DRY (NO VOLTAGE) contacts that CLOSE for the duration of screw recovery. See Figure 5, electrical diagram.

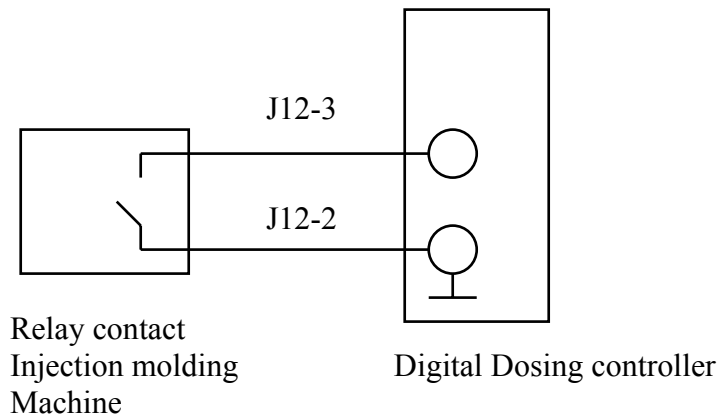

**(Electrical diagram of connections)**

***Figure 5. Electrical Diagram***

- **Extrusion-Constant:** Wire the cycle/run slave cable (thin two- conductor cable) to a set of DRY (NO VOLTAGE) contacts that CLOSE when the screw rotates. See Figure 6 for electrical diagram.
- **Extrusion-Proportional:** Wire the cycle/run slave cable to the extruder signal output that is proportional to the extruder speed. The signal output can be one of the following: 0-10VDC or 0-20mA. *Please refer to the labels on the cycle/run slave cable for the correct input to avoid damaging the controller.* Digital Dosing Additive Feeder is configured from the factory for each specific input. See Figure 5 for the electrical diagram for voltage inputs. See Figure 6 for frequency inputs.

***NOTE: Voltage from Drive needs to be isolated. Consult factory for other signal requirements. External converter signal may be required.***

**NOTE: Zero input corresponds to zero screw speed and no additive dosing. Maximum input corresponds to maximum screw speed.**

**NOTE: If a 0-10kHz frequency input is used, it must be a square wave with an amplitude of 12VDC. The shape of the signal is important, especially above 7,000Hz.**

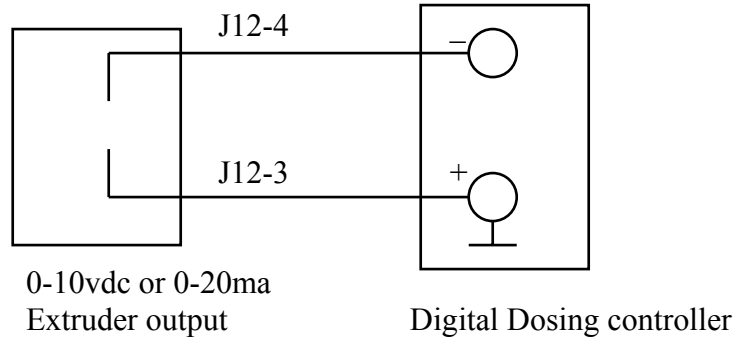

**(diagram of frequency inputs)**

**Figure 6. Frequency Inputs**

5. Make sure the unit is turned OFF before plugging it in. The switch toward the rear of the controller unit should be in the OFF, or “O” position. Standard operation voltage is 110 or 220 VAC, 50/60 Hz, single-phase power. Special voltages are available, refer to voltage label on the feeder to determine the correct operating voltage.

## 3.2 Initial Operation

The control system is factory-programmed. Nevertheless, specific values need to be predefined or checked prior to operation (basic parameter settings). The input values will be saved and will still be available if the unit is switched off, or a power failure occurs. Please refer to Appendix B for these values. **Extrusion operations require a “span factor” to be entered into the basic settings.** Please refer to Appendix B.

Prior to putting your new Digital Dosing Additive Feeder on-line:

- You must enter a recipe and calibrate the feeder.

- Recipe parameters are different for Injection Molding, Extrusion-Constant, and Extrusion-Proportional operation. See each individual section for details.
- The calibration method is the same for all processes.
- Once the unit is online, the user may want to save recipes for later recall (10 maximum).
- This section will show how to calibrate the unit, bring the unit on line, enter a recipe, and store and recall recipes.

### 3.3 Injection Molding



During each molding cycle the Digital Dosing unit doses the correct amount of additive evenly throughout the screw recovery cycle. The Digital Dosing unit determines the correct amount of additive from the recipe and automatically adjusts the duration and speed of dosing by measuring the molding machine screw recovery time each cycle.

#### Recipe Input - Injection Molding



To enter a recipe for injection molding, the following process data is required:

- Percentage of additive
- Total shot weight in grams (includes parts and runner system)
- Screw recovery time of the machine in seconds
- Calibration weight in grams



#### Step 1:

Press key	LED display	display
		"1" parts of the additive (colouring) in %

- Press Input  once.
- The LED symbol % flashes.
- "1" will quickly flash on the display, before a number in the format xxx.xx comes up on the display.



- Enter the additive percentage by using the Arrow Keys   . (The range of values that can be entered is 0.01% to 50.00%. The arrow keys are used to change all process variables. The double arrow key allows the user to ramp up or down by larger increments.)

### Step 2:

Press key	LED display	display
		"2" = shot weight in g or lb respectively

- Press Input  again.
- The symbols “g,” or “lb”, “min” and the screw symbol flash.
- After the “2” quickly flashes on the display, a number in the format xx.xxx will come up on the display.
- Enter the shot weight using the arrow keys. The range of values that can be entered is 001.0 to 6500 grams (0.01 to 14.30 pounds).

### Step 3:

Press key	LED display	display
		



- Press Input  a third time.
- The **screw** and “s” symbols flash.
- After “3” flashes quickly on the display, a number in the format xxx.xx will come up on the display.
- Enter the screw recovery time in seconds. This time represents the amount of time the molding machine screw is in recovery. **This value is an estimate.** The Digital Dosing unit measures the actual recovery time and automatically updates



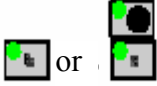

this value during operation. The range of values that can be entered in this field is 00.50 to 99.99 seconds.

#### Step 4:

Press key	LED display	display
		"4" = calibration weight in g or lb respectively, <b>if "0"</b> : carry out "calibration"

- Press Input  a fourth time.
  - The symbols "g" or "lb" and  flash.
  - After "4" quickly flashes on the screen, a number in the format xxxx.x will come up on the display.
  - Enter the material calibration weight using the arrow keys.
  - If the calibration weight is unknown, reference Section 5 of this manual.
- Complete the calibration procedure (section 3.6) to obtain the correct value. Upon completion of the calibration procedure, the calibration weight will automatically be updated into the recipe. The range of values that can be entered in this field is 00.0 to 400.0.



#### Step 5:

Press key	LED display	display
		"5" maintained running time of the blending unit in seconds

- Press  again and the symbol "s" will light up and the number "5" will be displayed **if you have a blending unit and have invoked this option.**



- After “5” flashes on the display, a number in the format xxx.xx will come up on the display.
- Enter the maintained running time of the blending unit in seconds using the arrow keys. This is how long the blender will run after each dosing cycle and should be adjusted for the best possible blend. Too little time may not produce good dispersion; too much time can cause separation, especially with heavy concentrates.

**Step 6:**

Press key	LED display	display
		“6” printer Only if a printer (optional) is available
 		enter printer parameters 0 = no printing 1 = printing setpoints 2 = printing parameters 3 = page change 4 = printing each event 5 = printing alarms



- Pressing  again, will activate the printing option **if it is available**.
- After the “6” flashes on the screen, a number in the format xxx.xx will come up on the display.
- By using the arrow keys, you can choose your printer parameters.













**Step 7:**

Press key	LED display	display
		total throughput in kg

- Pressing  again will first display the number “18” and then will display the total throughput in kilograms (totalizer).



### ***Operation-Injection Molding***

- Ensure that the unit is properly installed (Section 3.1), a recipe is entered (section 3.3.1), and the feeder is calibrated (Section 3.6), before attempting to begin operation.
- If desired, clear the totalizer by holding the Stop key () continuously for five seconds until the display is reset to “00.00.”
- Place the Digital Dosing feeder into operation by pressing the Run key (). The green LED will light when the unit is ready to dose.

Press key	LED display	display
	 or 	totalizer
	 	throughput
	 	rotational speed of the dosing motor
	 	nominal current of the motor in %

Start the molding machine. The Digital Dosing feeder will not dose material until the molding machine screw recovers. If the unit is installed properly, the process machine symbol  will

light on the controller during screw recovery. The disc symbol  will light when the Digital Dosing unit is dosing material.

- The totalizer will increase after each cycle by the amount of material dosed.
- To stop the dosing process, press .
- While the unit is dosing, the current recipe can be viewed, but not modified by pressing . The recovery time displayed in the current recipe is the average of the last five shots measured from the molding machine. To change the recipe, the unit must be taken off line by pressing the stop key. The run LED will then go out.

**NOTE: See Appendix A, Troubleshooting, for information on problems or errors encountered and their resolution.**

### 3.4 Extrusion Constant



In Extrusion Constant operation, the Digital Dosing unit doses material at a constant rate that does not change with extruder speed. The dosing process begins at the startup of the extruder. How close the actual extruder speed is to the input recipe will determine the accuracy of the blend. **If the process requires the additive to be dosed in proportion to the process speed, then the Digital Dosing unit must be configured for Extrusion Proportional operation (go to Sec. 3.5 on page 23).**





#### *Recipe Input – Extrusion Constant*

To enter a recipe for Extrusion Constant, the following process data is required:





- Percentage of additive
- Total throughput rate of the extruder during production
- Calibration weight in grams



#### Step 1:

Press key	LED display	display
		"1" parts of the additive (colouring) in %



- Press  once.
- The % symbol will flash.
- After “1” flashes on the screen, a number in the format xxx.xx will come up on the display.
- Enter the additive percentage by using the Arrow Keys   . The range of values that can be entered is 0.01 to 50.00%. The arrow keys are used to change all process variables. The double arrow key allows the user to ramp up or down at a faster rate.



### Step 2:

Press key	LED display	display
	OR  lb b2w.  g  min	“2” throughput of the extruder in g/min or lb/min



- Press  again.
- The symbols “g,” or “lb”, “min”, and  flash.
- After “2” flashes quickly on the display, a number in the format xxx.xx will come up on the display.
- Enter the total extruder throughput in grams per minute or pounds per minute. The range of values that can be entered is 001.0 to 6500 grams per minute (00.01 to 14.30 lb/m).

### Step 3:

Press key	LED display	display
	OR  lb OR  g	“4” calibration weight in g or lb respectively, if “0”: carry out “calibration”

- Press  a third time.
- The machine displays a flashing , “g” or “lb” and a number “4” flashes on the display (because this is Extrusion Constant, step 3 is skipped).
- After the “4” flashes on the display, a number in the format xxxx.x will come up.
- Enter the calibration weight. If the calibration weight is unknown, enter “00.00” and complete the calibration procedure (section 3.6) to obtain the correct value. Upon completion of the calibration procedure, the calibration weight will automatically be updated into the recipe. The range of values that can be entered in this field is 00.00 to 400.0.

#### Step 4:

Press key	LED display	display
		“6” printer Only if a printer (optional) is available
 		enter printer parameters 0 = no printing 1 = printing setpoints 2 = printing parameters 3 = page change 4 = printing each event 5 = printing alarms





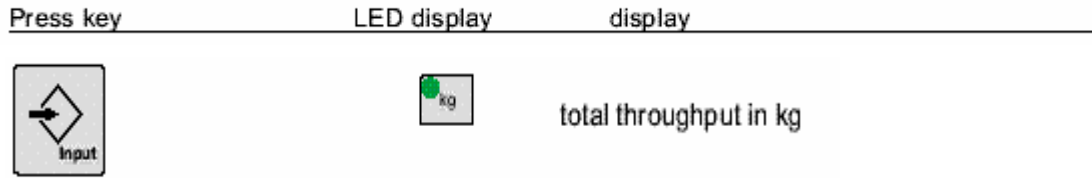

- Press  again. This will activate the printing option if it is available and the number “6” will be displayed.
- After the “6” flashes on the screen, a number in the format xxx.xx will come up on the display.
- By using the arrow keys, you can choose your printer parameters. **If you have not activated this option, skip to the next step.**

## Step 5:



6. Press  again.
7. The number “18” will be displayed before the total throughput in kg is displayed.

## *Operation –Extrusion Constant*

1. Ensure that the unit is properly installed (Section 3.1), a recipe is entered (Section 3.4.1), and the feeder is calibrated (Section 3.6), before attempting to begin operation.
2. If desired, clear the totalizer by pressing  continuously for 5 seconds until the display is reset to “00.00.”
3. Place the Digital Dosing unit into operation by pressing . The green LED will light when the unit is ready to dose, but the Digital Dosing unit will not feed until the extruder begins operation.
4. Start the extruder. The Digital Dosing unit will begin dosing material as soon as the extruder starts. If the unit is installed properly, the process machine symbol  will light on the controller when the extruder starts. The disc symbol  will light when the Digital Dosing unit is dosing material.
5. To stop the dosing process while the extruder is operating, press . The Digital Dosing unit will automatically stop dosing when the extruder stops.
6. While the unit is dosing, depending on software revision, the current recipe can be viewed but not modified, by pressing . In some software versions, the percent additive can be changed while the unit is dosing.

**NOTE:** See Appendix A, Troubleshooting, for information on problems or errors encountered and their resolution.



## 3.5 Extrusion Proportional





### *Recipe Input – Extrusion Proportional*

To enter a recipe for Extrusion Proportional, the following process data is required:

- Percentage of additive
- Expected throughput of the extruder during production
- Extruder screw speed during production
- Calibration weight in grams

#### Step 1:



Press key	LED display	display
		"1" parts of the additive (colouring) in %

- Press the Input key () once.
- The % symbol flashes.
- After "1" flashes quickly on the display, a number in the format xxx.xx will come up on the display.
- Enter the additive percentage by using the Arrow Keys   . The range of values that can be entered is 0.01% to 50.00%. The arrow keys are used to change all process variables. The double arrow key allows the user to ramp up or down at a faster rate.



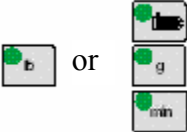



## Step 2:

Press key	LED display	display
		"2" throughput of the extruder in g/min or lb/min

- Press  again.
- The machine displays a flashing "g" or "lb", a flashing "min" and .
- After "2" flashes quickly on the display, a number in the format xxx.xx will come up on the display.
- Enter the expected extruder throughput during production in grams per minute or pounds per minute. The range of values that can be entered is 001.0 to 6500 grams per minute (00.01 to 14.30 lb/m).



## Step 3:

Press key	LED display	display
		"3" rotational speed of the extruder

- Press  a third time.
- The machine displays a flashing screw .
- After "3" flashes quickly on the display, a number in the format xxx.xx will come up on the display.
- Enter the extruder screw speed (rpm) corresponding to the throughput entered in step 2.

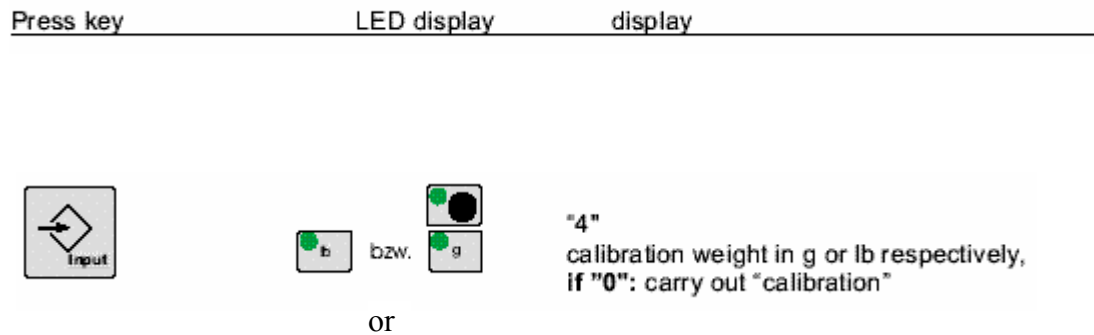
#### Step 4:









1. Press  a fourth time.
  2. The machine displays a flashing  and “g”.
  3. After “4” flashes quickly on the screen, a number in the format xxx.xx will come up on the display.
- Enter the calibration weight in grams or pounds. **If the calibration weight is unknown, enter “00.00” and complete the calibration procedure (section 3.6) to obtain the correct value. Upon completion of the calibration procedure, the calibration weight will automatically be updated into the recipe.** The range of values that can be entered in this field is 00.00 to 400.0.

#### Step 5:

- Press  a fifth time to return to the totalizer.

### ***Operation –Extrusion Proportional***

- Ensure that the unit is properly installed (Section 3.1)
  - A recipe is entered (“Recipe Input-Extrusion Proportional” Section )
  - The feeder is calibrated (Section 3.6), before attempting to begin operations.
1. If desired, clear the totalizer by pressing  continuously for 5 seconds until the display is reset to “00.00.”

2. Place the Digital Dosing unit into operation by pressing the Run key ().  
The green LED will light when the unit is ready to dose, but will not feed until the extruder begins operation.
3. Start the extruder. The Digital Dosing unit will begin dosing material as soon as the extruder starts. If the unit is installed properly, the process machine symbol  will light on the controller when the extruder starts. The disc symbol  will light when the Digital Dosing is dosing material
4. To stop the dosing process while the extruder is operating, press . The Digital Dosing unit will automatically stop dosing when the extruder stops.
5. While the unit is dosing, depending on software revision, the current recipe can be viewed but not modified, by pressing . In some software versions, the percent additive can be changed while the unit is dosing. The actual extruder screw speed will be displayed in the third recipe register.

### 3.6 Calibration

All feeders must be calibrated before any blending recipes can run using the Digital Dosing additive feeder.

***NOTE: The calibration weight (metered material weight for one revolution of the dosing disc) must be determined separately for each material to be dosed since calibration weight differs from material to material.***

The following equipment is needed for calculating the calibration weight:

- Scale with a minimum accuracy of 0.01 grams
- The weighing container which is included in the equipment delivery

Follow these procedures:

1. Remove one of the square covers and insert the calibration container provided.
2. Fill the dosing hopper with a minimum of six (6) inches of material.
3. Note weight of weighing container (= tare weight) or tare scale to zero

***NOTE: The Digital Dosing station may only be operated if all sample chutes are in place or a collecting bin is in the calibration box.***

## Determining the Calibration Weight

### Step 1:

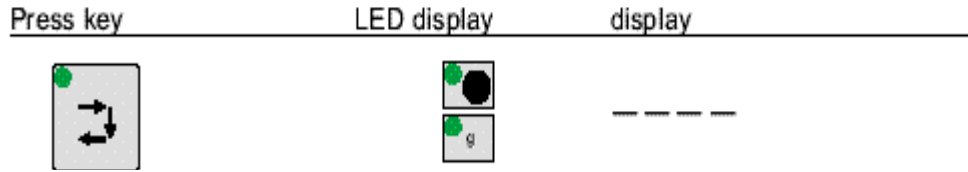

- To start the calibration process, press the calibration key.

### Step 2:

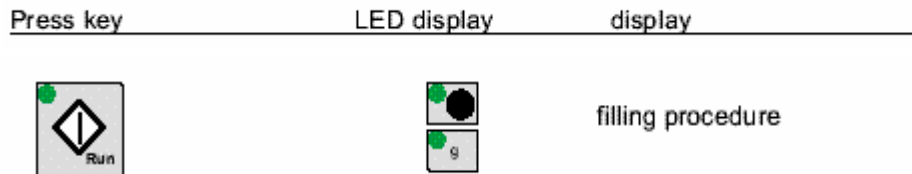

- Once the sample container is in position, press .
- The disc will rotate 1/4 revolution and dispense material into the sample container. After the disc stops, the screen will remain blank.
- **This sample should be returned to the material hopper without weighing.** This sample is used only to ensure that all disc pockets are completely filled.
- Replace container in calibration box (or under material outlet tube)

### Step 3:

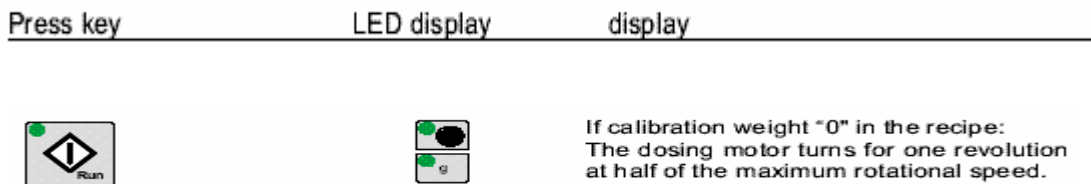

- Press  to take a sample for weighing.



- The disc will rotate one full revolution. After the disc has stopped rotating, a number in the format “xx.xx” will appear on the screen along with a flashing  and “g.”

**Step 4:**

Press key \_\_\_\_\_ LED display \_\_\_\_\_ display \_\_\_\_\_



“proportioning” and entry of the weight

- Enter the weight, in grams using the Arrow Keys   
- Empty and replace weighing container in calibration box (or under material outlet tube)

**Step 5:**

- Repeat steps 3 and 4 four (4) more times.
- Notice that the displayed calibration weight may change after each sample weight is entered.
- **The value is an average of all the weights entered. No calculations are required.** It can happen that the calculated speed is either too high or low causing alarm A0009. Check the recipe and settings and modify if necessary.

**Step 6:**

Press key \_\_\_\_\_ LED display \_\_\_\_\_ display \_\_\_\_\_



terminate proportioning **while not taking** on the calibration weight

or



terminate proportioning **while taking** on the calibration weight

- Pressing the stop button will stop proportioning and not accept the calibration weight.
- Pressing the calibration button will stop proportioning and accept the calibration weight.

***NOTE: It is normal for calibration weights to vary slightly from sample to sample.***

## **Section 4: Advanced Operations/ Control Functions**

### **4.1 Recipe Storage And Recall**

A maximum of ten (10) recipes can be stored and retrieved with the Digital Dosing controller in the Recipe Storage/Recall mode. Recipes are stored using a two-digit identification number.

Pressing  at any time will exit the Recipe Storage/Recall mode.

#### ***Recipe Storage***

To store the current recipe:

Press key	LED display	display
-----------	-------------	---------



"L (= load)" and the most recently called up recipe number



"S (= save)" and the most recently saved recipe number

#### **Step 1:**

- Press the Recipe Storage/Recall key (). A two-digit number (01 through 10) will appear on the screen. This is the recipe I.D. number.

#### **Step 2:**

- Use the Arrow keys    to select the desired recipe number.

***NOTE: A new recipe stored under the ID number of an existing recipe will overwrite the existing recipe number without warning.***

#### **Step 3:**

Press key	LED display	display
-----------	-------------	---------

or

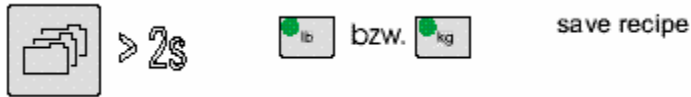

- Press and hold the button  until the totalizer display returns to the screen.
- The recipe is now stored under the selected ID number.

## Recipe Recall

### Step 1:

Press key	LED display	display
	lb or kg	totalizer

- Press the stop button to stop any current applications.

### Step 2:

Press key	LED display	display
		"L (= load)" and the most recently called up recipe number

- Press the Storage/Recall key () once.
- A two-digit recipe ID number will appear on screen.

### Step 3:

- Use the Arrow Keys    to select the desired recipe number.

### Step 4:

Press key	LED display	display
-----------	-------------	---------

OR



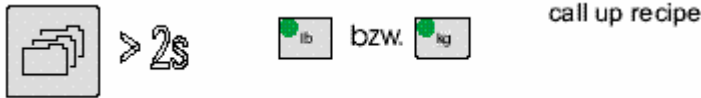



- Press and hold  until the totalizer appears on the screen.
- The recipe is now active and can be run or edited.

**NOTE:** *The recalled recipe now becomes the active recipe.*

## 4.2 Clearing The Totalizer

- The totalizer displays the total amount of additive dosed since the last time the totalizer was cleared.
- The totalizer can be cleared by pressing Stop  continuously for 5 seconds until the display is reset to “00.00.” The totalizer can be configured to read throughput in grams or pounds.
- See Appendix A to learn how to change the unit of measure.

## 4.3 Acknowledging Alarms

- When an alarm occurs, the Alarm symbol  flashes red and the dosing process stops.
- If the Digital Dosing is equipped with an audible alarm or flashing light, it will also be activated.
- Alarms are acknowledged by pressing .
- The alarm will also initiate an error code.
- See Appendix A for Troubleshooting suggestions for various alarms.
- The alarm condition **must be corrected** prior to beginning operation again.

## 4.4 Optional Equipment

Optional equipment for the Digital Dosing Additive Feeder includes:

## Alarms

Several alarm options are available for the Digital Dosing feeder. The standard unit comes with a flashing alarm symbol  on the faceplate. Options include both audible horns and flashing lights. An optional no voltage alarm relay can be connected to the user's central alarm system.

## Level Probes

To adjust the level probes:

1. Turn the controller ON.
2. Fill the dosing station until the level sensor is one-third covered.
3. Remove the small plastic screw (M3) on the back of the level sensor (see Figure 7).

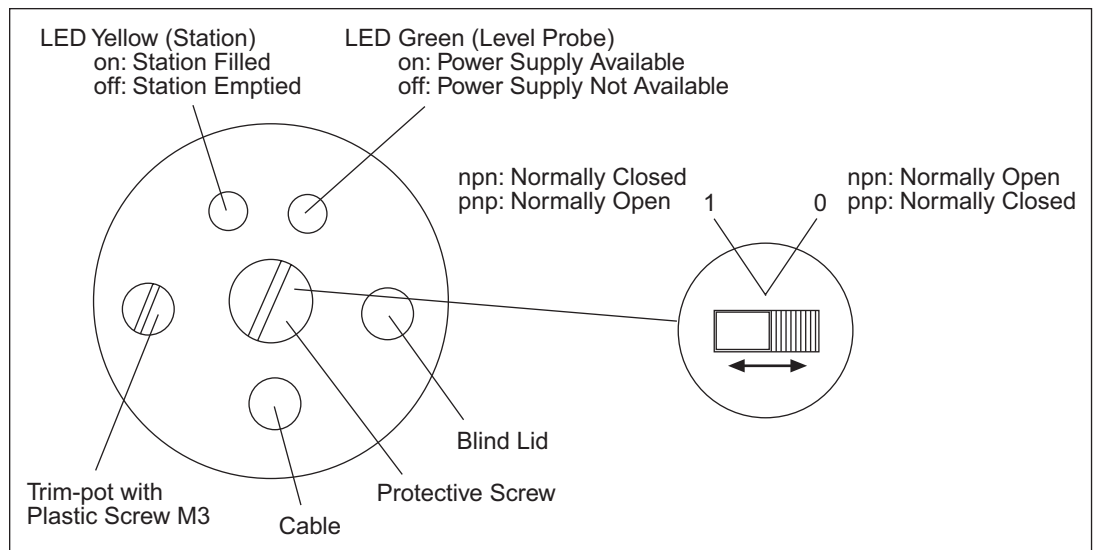

Level Probe

**Figure 7. Level Sensor Screw**

4. Turn the trim-pot until the yellow control lamp just switches off.

**NOTE:** *Turning the trim-pot to the left decreases the switching sensitivity; turning it to the right increases the switching sensitivity.*

5. Fill the dosing station until the level probe is two-thirds covered. The yellow control lamp should now switch on again. If not, repeat Step 4.
6. Reinstall the plastic screw (M3).

**NOTE:** *The sliding switch under the cover must be set on "0".*

### ***Mixer***

An optional mixer is available that can be mounted under the Digital Dosing unit. The mixer is used to help distribute fine powders and granules. During the injection molding process, the mixer only runs during screw recovery (when the Digital Dosing unit is dosing additives). During extrusion processes, the mixer operates continuously when the extruder is operating and the Digital Dosing unit is in run mode.

### ***EUROMAP E17 Interface***

The Digital Dosing unit can be controlled remotely through the EUROMAP E17 protocol. Contact Sales and Service concerning this option. (800) 423-3183 or (414) 354-0970.

## **Section 5: Maintenance**

### **5.1 Maintenance Intervals**

<b>Daily:</b>	Check warning signs on equipment for good legibility and completeness.
<b>Weekly:</b>	Check function of the on/off Switch.
<b>Every 3 months:</b>	Check scraper in dosing station DD/DT.
<b>Every 6 months:</b>	Check all electrical and mechanical connections for tight fit. Check adjustment of the level probes (optional).
<b>Annually:</b>	Check dosing disc in dosing station DD/DT.
<b>Each time after material is changed:</b>	Clean the dosing station. Check scraper. Check dosing disc.

### **5.2 Removing the Scraper**

#### *Removing the scraper*

1. Empty the dosing station.
2. Open the profile clamp (B) on the dosing hopper.
3. Remove the dosing hopper from the dosing unit.
4. Open the safety screws at the toggle-type fasteners.
5. Open the toggle-type fasteners on the dosing motor.

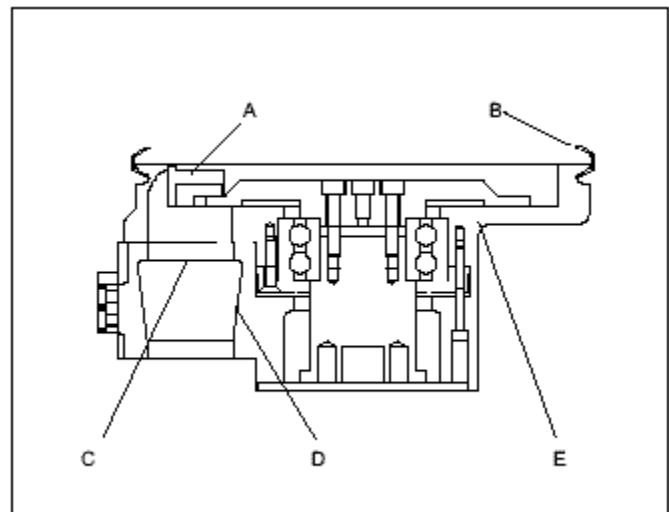

Dosing unit (side view)

6. Remove the dosing unit from the dosing motor.
7. Remove the cover from the connecting piece (D).
8. Loosen the two screws (C) on the underside of the dosing unit housing (E).
9. Remove the scraper (A).

### ***Installing the scraper***

1. Place the new scraper in the dosing unit housing.
2. Ensure that the scraper is positioned correctly.
3. Screw the scraper in place by means of 2 hexagon socket screws (M5 x 16).
4. Turn the dosing disc to check for smooth movement.
5. Mount the cover on the connecting piece.
6. Position the dosing unit on the dosing motor (note guide pins).
7. Close the toggle-type fasteners on the dosing motor.
8. Mount the safety screws.
9. Position the dosing hopper on the dosing unit.
10. Mount the profile clamp.
11. Mount the screw at the profile clamp.

## **5.3 Cleaning the Digital Dosing Dosing Station**

### ***Dismantling the Dosing Station***

1. Empty the dosing station.
2. Switch the control unit off by means of the on/off switch.
3. Disconnect from main voltage.
4. Open the profile clamp on the dosing hopper.

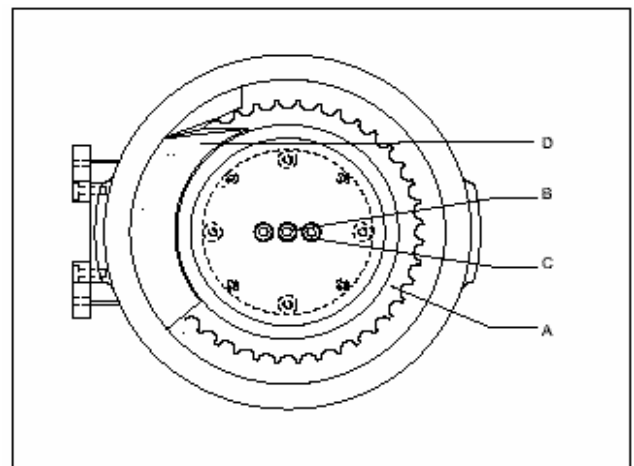

Dosing unit (top view)

5. Remove the dosing hopper from the dosing unit.
6. Dismantle the dosing unit and remove the scraper (D).
7. Loosen the two hexagon socket screws (B, M6 x 30) on the top side of the dosing disc (A).
8. Loosen the center hexagon socket screw (C, M6 x 12) and replace by an M6 x 60 screw.
9. Lift the dosing disc (A) from the dosing unit housing (B) by this screw.
10. Clean the scraper using a cotton cloth.
11. Clean the dosing hopper and the dosing disc in soapy water.
12. The dosing unit housing may also be cleaned with soapy water.
13. Ensure that soapy water does not enter ball bearings.
14. Dry all parts thoroughly.

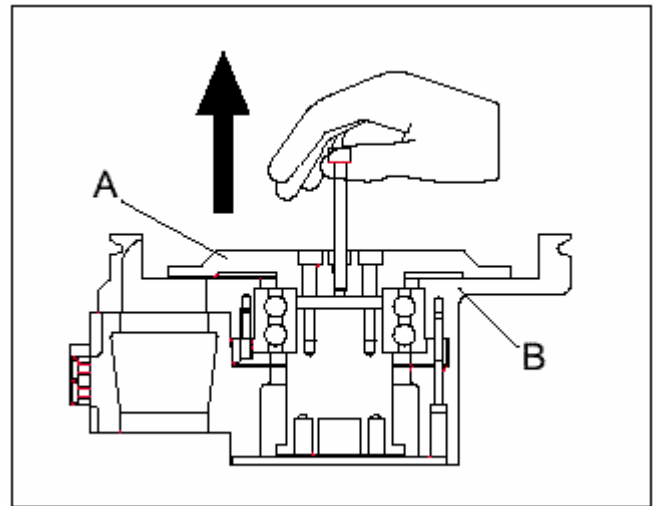

Dosing unit (side view)

### ***Installing the Dosing Station***

1. Place the dosing disc in the dosing unit housing.
2. Remove the screw (M6 x 60).
3. Screw the dosing disc in place by means of 2 hexagon socket screws (M6 x 30).
4. Mount the center hexagon screw (M6 x 12).
5. Install the scraper and then the dosing unit.
6. Turn the dosing disc to check for smooth movement.
7. Position the dosing hopper on the dosing unit.
8. Tighten the profile clamp.

## **5.4 Changing the Dosing Disc in the Digital Dosing Dosing Station**

### ***Removing the Dosing Disc***

1. Empty the dosing station.
2. Switch the control unit off by means of the on/off switch.
3. Dismantle the dosing unit and remove the scraper.
4. Loosen the two hexagon socket screws (M6 x 30) on the top side of the dosing disc.
5. Loosen the center hexagon socket screw (M6 x 12) and replace by a M6 x 60 screw.
6. Lift the dosing disc from the dosing unit housing by this screw.

### ***Installing the Dosing Disc***

1. Change and place the dosing disc in the dosing unit housing.
2. Remove the screw (M6 x 60).
3. Screw the dosing disc in place by means of 2 hexagon socket screws (M6 x 30).
4. Mount the center hexagon socket screw (M6 x 12).
5. Install the scraper and then the dosing unit.
6. Turn the dosing disc to check for smooth movement.
7. Position the dosing hopper on the dosing unit.
8. Tighten the profile clamp.

**See Appendix D: Spare Parts List on page 61 for disc part numbers.**

### ***Installing Different Types of Dosing Discs***

Dosing discs of the same type may be exchanged for each other without any problems. If dosing discs with a different compartment number are installed, this has to be entered in the control system!

1. Enter the (preliminary) calibration value of the freshly installed dosing disc (\* = bulk density 550g/l, \*\* = bulk density 700g/l).

Dosing disc	Preliminary calibration value
DD30-030672	*1.5 , **2.0
DD30-051040	*4.0 , **5.0
DD30-051725	*7.0 , **9.0
DD30-051818	*13.0 , **17.0

2. Execute “calibration” to determine the final calibration value.

### **5.5 Removing/Replacing the Scraper in the DT Dosing Station**

1. Empty the dosing station.
2. Open the profile clamp (C) of the dosing container.
3. Remove the profile clamp (C)
4. Remove the dosing container (B) along with the dosing hopper (A).
5. Loosen the 3 plastic screws on the stripper (DT-t: metal screws).
6. Remove the scraper and holding plate.
7. Install the new scraper along with the holding plate.
8. Tighten down the 3 plastic screws. Make sure that the stripper is fitted parallel to the dosing plate (Use only plastic screws (DT-t: metal screws)).

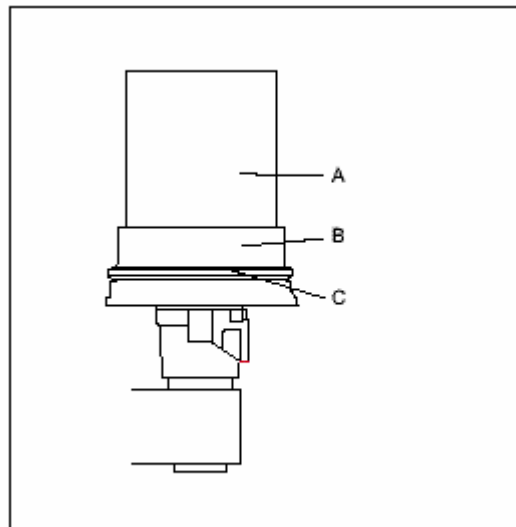



9. Install the dosing container along with the dosing hopper on the dosing housing (pay attention to the guide pins).
10. Mount the profile clamp.
11. Mount the screw at the profile clamp.

## 5.6 Cleaning the DT Dosing Station

1. Empty the dosing station.
2. Switch the control unit off by means of the on/off switch.
3. Disconnect from mains voltage.
4. Open the profile clamp (C) of the dosing container.
5. Remove the profile clamp (C).
6. Remove the dosing container (B) along with the dosing hopper (A).
7. Open the safety screws at the toggle-type fasteners.
8. Open the toggle-type fasteners.
9. Remove the dosing housing (D) from the mixing hopper.

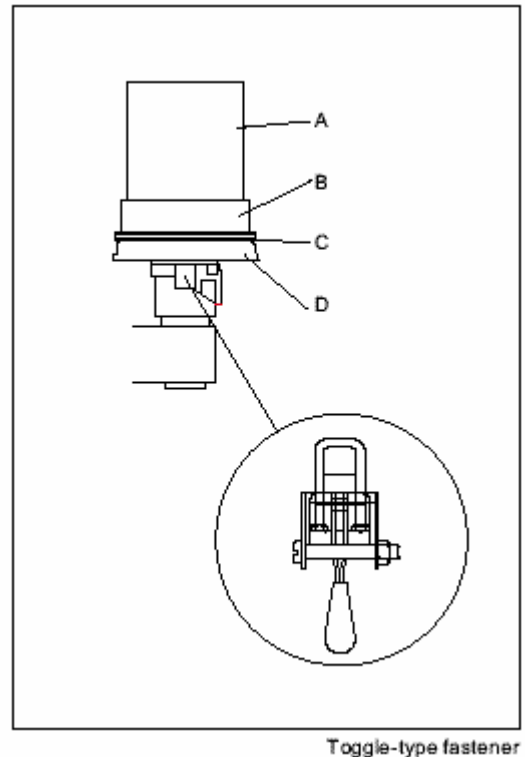

10. Clean the dosing housing (D) with a paintbrush.
11. Clean the dosing container (B) and the dosing hopper (A) in soapy water.
12. Dry all parts thoroughly.
13. Mount the dosing housing onto the dosing motor.
14. Observe that the guide pins are locked into position.
15. Close the toggle-type fasteners.
16. Mount the safety screws.

17. Install the dosing container along with the dosing hopper on the dosing housing (pay attention to the guide pins).
18. Mount the profile clamp.
19. Mount the screw at the profile clamp and tighten.

## 5.7 Exchangeable Stations

Dosing discs of the same type may be exchanged for each other without any problems. If dosing discs with a different compartment number are installed, this has to be entered in the control system.

1. Enter the (preliminary) calibration value of *the freshly installed* dosing disc (\*=bulk density 550g/l, \*\* = bulk density 700g/l).

Feed station	Number of dosing compartments	Preliminary calibration value
DD30-030672	72	*1.5 , **2.0
DD30-051040	40	*4.0 , **5.0
DD30-051725	25	*7.0 , ** 9.0
DD30-051818	18	*13.0 , **17.0
DT30-101820	20	*28.0 , **35.0
DT30-203012	12	*93.0 , **118.0
DT30-204010	10	*148.0 , **190.0

2. Execute “calibration” to determine the final calibration value.

## 5.8 Replacing Fuses

1. Stop the continuous operation.
2. Wait until the dosing unit has come to a standstill.
3. Switch off the device by means of the on/off switch.
4. Cut off the voltage supply.
5. Wait at least one minute before starting to work at the switching cabinet.

6. Never try to repair a defective fuse.

7. Open the screws (A) and remove the lid (B).

8. Remove the blind lid (C) and open the screws.

9. Move the lid (D) aside.

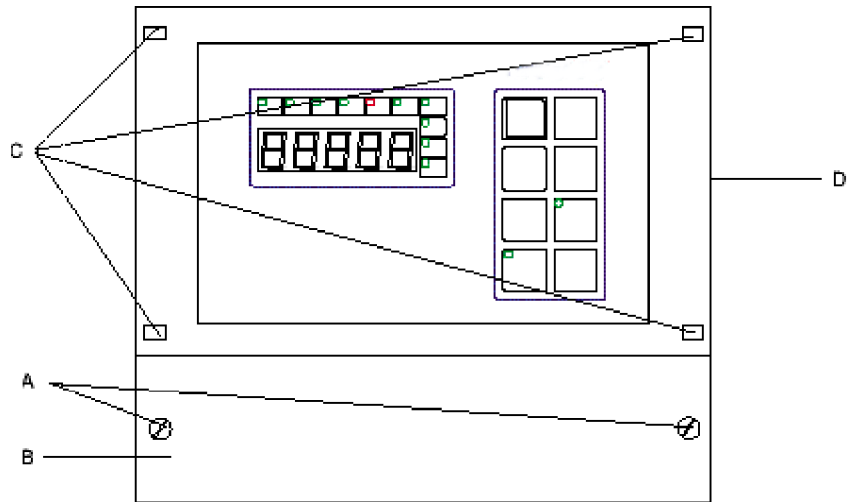

10. Remove the defective fuse from the fuse carrier.

11. Install the new fuse (while observing the value).

12. Mount the lid (D).

13. Fasten the screws and the blind lids (C).

14. Mount the lid (B).

15. Mount the screws (A).

**See Appendix D on page 61 for fuse part numbers.**



# **Appendix A: Troubleshooting**

During setup and use of the Digital Dosing Additive Feeder, personnel may experience difficulties. Some of the problems encountered may be resolved using the following techniques.

## **A.1 General Troubleshooting - Unit Will Not Operate**

- Check all connections and process wiring. Note that the process machine input **MUST** be wired to a DRY contact for Injection Molding (Section 2.8.1) and Extruder Constant Applications (Section 2.8.2). For Extrusion Proportional Application see Section 2.8.3.
- Ensure the correct Configuration Codes have been entered to configure the Digital Dosing unit for the process and installation, see Section A.4.

## **A.2 Malfunctions or Errors - Error Codes**

When a malfunction or error occurs, the controller displays the Alarm symbol  and an error code. The code consists of an “A,” followed by an error number. The control unit will not operate until the malfunction or error has been corrected. To acknowledge and clear the alarm, press the Stop key (). Once the malfunction is corrected, press  to begin dosing operations.

**NOTE:** Stop  *will not correct a malfunction or error.*

Following is a table with the error codes, possible reasons for each code, and solutions to the problems presented.

## ERROR CODES

Code	Definition	Possible Reason/Solution
A001	Strap "safety switch" is missing.	Manufacturer Service.
A002	The nominal current of the dosing motor (=100%, see name plate) is being exceeded for more than 2 seconds by 30% or for a maximum of 0.5 seconds by 80%.	Dosing motor defective or jammed. Check the dosing motor and exchange it if necessary. Check whether the dosing disc is jammed by material and remove the material if necessary.
A003	The nominal current of the dosing motor (=100%, see name plate) is being exceeded for more than one minute.	Dosing motor defective or jammed. Check the dosing motor and exchange it if necessary. Check whether the dosing disc is jammed by material and remove the material if necessary.
A004	Excess temperature. The temperature within the controller housing is > 85°C	Check whether the cooling plate at the back of the controller is sufficiently cooled down. Use fan if necessary.
A005	The encoder (pulse generator) does not emit any pulses for approximately 2 seconds.	If dosing motor does not turn, check whether the dosing disc is jammed by material and remove the material if necessary. If disc is free, check the dosing motor, exchange if necessary. If motor operates, but alarm persists, check speed encoder output. Replace as necessary.
A006	For approximately 4 seconds, there is a deviation of the motor speed of more than 20% from the nominal rotational speed.	Defect at the dosing motor. Check dosing motor, exchange if necessary. Check whether the dosing disc is jammed by material and remove the material if necessary. Power supply part or control out of order. Manufacturer Service.
A007	Dosing motor stops or doesn't work.	Brake at the dosing motor out of order. Control system out of order. Manufacturer service.
A008	The screw retract time of the processing machine is shorter than 0.1 seconds.	The unit cannot be operated in combination with this processing machine.
A009	The calculated speed of the motor is either too high or too low.	Check basic parameter settings and recipe, modify if necessary. May require changing to different sized dosing disc.
A0010	The feed station is not able to meter the desired recipe.	Check basic parameter setting and recipe, modify if necessary. May require changing to different sized dosing disc.
A0011	The raw material probe is not covered	Refill Material.
A0012	The additive probe is not covered.	Refill material.
A0014	Power failure interrupted run cycle.	Clear alarm after power restored.
A0015	EEPROM data loss, EEPROM not programmed.	Manufacturer Service.
A0016	No communication between HOST and unit.	Check cable fittings. Manufacturer Service.

### A.3 Determining the Software Setup Factor

The Digital Dosing control unit is configured via a Software Setup Factor (binary code). To determine the Software Setup Factor answer the following questions: If the answer is “yes” enter the code number in the selection column. If the answer is “no” enter “0” in the selection column. When all the questions have been answered and the selection column is completed, add up the total for the selection column. The total is the Software Setup Factor.

### A.4 Recipe Formulas

The following formulas can be used to determine if a recipe is appropriate or possible.

#### *Injection Molding*

For injection molding applications, compute the dosing disc speed and total number of disc revolutions using the following formulas. Recipe limitations are listed in the table following the equations.

$$\text{Disc RPM} = \frac{(\text{Shot Weight} - \text{g}) \times (\text{Additive} - \%) \times 0.6}{(\text{Disc Calibration Weight} - \text{g}) \times (\text{Recovery Time} - \text{s})}$$

$$\text{Disc Revolutions per Shot} = \frac{(\text{Shot Weight} - \text{g}) \times (\text{Additive} - \%) \times 0.01}{(\text{Disc Calibration Weight} - \text{g})}$$

#### **Recipe Limitations for Injection Molding**

Motor Assembly Speed (rpm)	Maximum	
	Speed (rpm)	Number of Disc Revolutions
12	12.5	4.6
38	40.0	14.8

#### *Extrusion*

For extrusion applications compute the dosing disc speed using the following formula. Recipe limitations are listed in the table following the recipe.

$$\text{Disc RPM} = \frac{(\text{Additive} - \%) \times (\text{Total Extruder Throughput} - \text{lb} / \text{hr})}{13.22 \times (\text{Disc Calibration Weight} - \text{g})}$$

### Recipe Limitations Extrusion

Motor Assembly Speed (RPM)	Maximum Speed (RPM)
12	12.5
38	40.0

# Appendix B: Basic Parameter Settings

## Extrusion Mode:

You need an extruder signal that is proportional to the extruder speed to operate in the Extrusion

Proportional mode. You can use any of the following:

- Frequency signal (must be 12VDC square wave)
- 0-20mA current signal
- 0-10VDC signal

Determine the frequency output in the lower working area (A) of the extruder. Record the data.

Min. input frequency = \_\_\_\_\_ Hz

Determine the frequency output in the upper working area (B) of the extruder. Record the data.

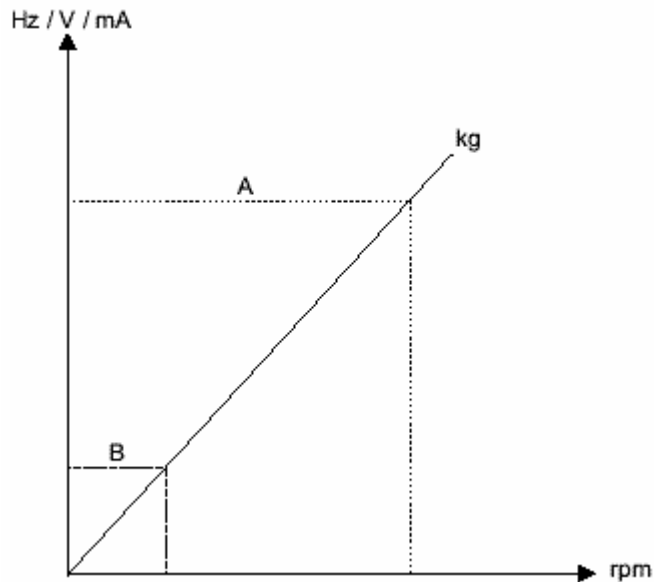

**Max. input frequency = \_\_\_\_\_ Hz**

If a **voltage** signal is available (0 - 10 VDC) calculate the frequency output of the extruder for the lower / upper working area using the formula:

$$\text{Frequency [Hz]} = \frac{\text{Input voltage [V]} \times 10000 \text{ [Hz]}}{10 \text{ [V]}}$$

Note the data:

Min. input frequency = \_\_\_\_\_ Hz

Max. input frequency = \_\_\_\_\_ Hz



If a **current** signal is available (0 - 20 mA) calculate the frequency output of the extruder for the lower / upper working area using the formula:

$$\text{Frequency [Hz]} = \frac{\text{Input current [mA]} \times 10000 \text{ [Hz]}}{20 \text{ [mA]}}$$

Note the data:

Min. input frequency = \_\_\_\_\_ Hz

Max. input frequency = \_\_\_\_\_ Hz

Calculate the **span factor** using the formula:

$$\text{Span factor [Hz / rpm]} = \frac{\text{Frequency [Hz]}}{\text{Rotational speed of the extruder [rpm]} \times 10}$$

Note the data:

**Span factor** = \_\_\_\_\_

## Determining the Configuration Value

### ***Extrusion (Constant or Proportional):***

Mark the functions required. Use the numerical value indicated and insert it in the empty field if applicable. Total the figures for configuration value.

Optional raw material level probe installed . . . . . 1    \_\_\_

Optional additive level probe installed . . . . . 2    \_\_\_

Optional blending unit installed . . . . . 8    \_\_\_

Totalizer displayed in lb (kg default) . . . . . 16    \_\_\_

Extruder throughput 1-6500 g/min . . . . . 0    \_\_\_

or

Extruder throughput (1-6500 g/min) X 10 . . . . . 32    \_\_\_

or

Extruder throughput (1-6500 g/min) / 10 . . . . . 128    \_\_\_

***(NOTE: the throughput selections above determine placement of the decimal point on the display)***

External run/stop signal controls dosing . . . . . 64    \_\_\_

Mounting on Mico mixing hopper . . . . . 256    \_\_\_

Alarm output is switched in case of power failure . . . . .	512	___
Extrusion mode . . . . .	1024	___
Printer available . . . . .	16348	___
Configuration value: . . . . .		_____

Example:

- Level probes: raw material and additive probes installed
- Throughput: 8000 g/min
- Totalizer displayed in lbs
- Extrusion mode

. Raw material probe . . . . .	1	<u>1</u>
. Additive probe . . . . .	2	<u>2</u>
. Blending unit . . . . .	8	___
. Totalizer displayed in lb. . . . .	16	<u>16</u>
. Throughput 1-6500 g/min . . . . .	0	
or		
. Throughput (1-6500 g/min) X 10 . . . . .	32	<u>32</u>
or		
. Throughput (1-6500 g/min) / 10 . . . . .	128	___
. External run/stop signal controls dosing . . . . .	64	___
. Mounting on a Mico mixing-hopper. . . . .	256	___
. Alarm output switched in case of power failure . . . . .	512	___
. Extrusion mode . . . . .	1024	<u>1024</u>
. Printer available . . . . .	16348	___
Configuration value: . . . . .		<u>1075</u>

***Injection Molding:***

Mark the functions required. Use the numerical value indicated and insert it in the empty field if applicable. Total the figures for configuration value.

Optional raw material level probe installed . . . . .	1	___
Optional additive level probe installed . . . . .	2	___
Optional blending (mixing) unit installed . . . . .	8	___

















Totalizer displayed in lb (kg default) . . . . .	16	___
Shotweight up to 6.5 kg . . . . .	0	
or		
Shotweight 6.5 to 65 kg . . . . .	32	___
<i>(NOTE: The shotweight selections above determine placement of the decimal point on the display)</i>		
External run/stop signal controls dosing . . . . .	64	___
Mounting on Mico mixing hopper . . . . .	256	___
Alarm output is switched in case of power failure . . . . .	512	___
Printer available . . . . .	16348	___
Configuration value: . . . . .		___

































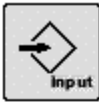



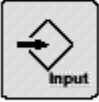

Example:













- Level probes: additive probe installed
- Shotweight: 8 kg
- Totalizer displayed in lb

Raw material probe . . . . .	1	___
Additive probe . . . . .	2	<u>2</u>
Blending unit . . . . .	8	___
Totalizer displayed in lb. . . . .	16	<u>16</u>
Shotweight up to 6.5 kg . . . . .	0	
or		
Shotweight 6.5 to 65 kg . . . . .	32	<u>32</u>
External run/stop signal controls dosing . . . . .	64	___
Mounting on a Mico mixing-hopper. . . . .	256	___
Alarm output switched in case of power failure . . . . .	512	___
Printer available . . . . .	16348	___
Configuration value: . . . . .		<u>50</u>

## Basic Parameter Settings

Press key	LED display	display
 		"7" pulses of the encoder regulation: 14103 (12 rpm), 4387 (38 rpm), 11739 (6.5 rpm), 2135 (35.5 rpm) or 2100 (Colorblend S) respectively
 		enter the impulses of the encoder
		"8" nominal current of the motor Bauer motor: 0.7 A Bison motor: 0.5 A Colorblend S: 0.5 A
 		enter the nominal current of the motor
		"9" configuration value see list "Determining the Configuration Value"
 		enter configuration value

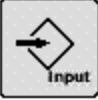
Press key	LED display	display
	         	"10" configuration value: 1, if Bauer motor present
 	         	enter configuration value
	 	"11" minimum input frequency Only extruder operation with external desired value specification
 	 	enter input frequency
	   	"12" span factor Only extruder operation with external desired value specification
 	   	enter span factor

Press key	LED display	display
		"13" communication address Only if Euromap17-report is in use
 		enter communication address
		"14" material contents of the mixing hopper, standard regulation: 5000 g Only in case of mounting on a Mico mixing-hopper
 		enter material contents
		pulses of the encoder regulation
		or
		quit the menu at any time while taking on the entered values

# Appendix C: Disc Dosing Factors And Equipment Drawings And Parts Numbers

**Disc Dosing Factor Table 1: Disc Guide**

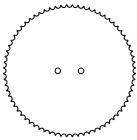
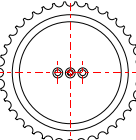
Disc	Disc Nomenclature Used in the Controller	Minimum/Maximum Disc Revolution	Weight Per Disc Revolution (Bulk Density 35lb/cuft)	Min. Throughput with 100% Continuous Running (Bulk Density 35lb/cuft)	Max. Throughput with 100% Continuous Running (Bulk Density 35lb/cuft)	Weight Per Disc Revolution (Bulk Density 44lb/cuft)	Min. Throughput with 100% Continuous Running Bulk Density 44lb/cuft)	Max. Throughput with 100% Continuous Running (Bulk Density 44lb/cuft)
<b>DD30-030672</b> 	P030672 # of Holes Diameter Disc Thickness	0.2 Rev./min 6.4 Rev./min (6.4 RPM)	1.53 g/Rev. 0.02 g/Hole	0.04 lb/hr 0.02 kg/hr	1.30 lb/hr 0.59 kg/hr	1.95 g/Rev. 0.027 g/Hole	0.04 lb/hr 0.02 kg/h	1.65 lb/hr 0.75 kg/h
<b>Default Calibration # 1.50 g/rev</b>		0.5 Rev./min 11.5 Rev./min (11.5 RPM)		0.10 lb/hr 0.045 kg/hr	2.32 lb/hr 1.05 kg/hr		0.12 lb/hr 0.05 kg/hr	2.89 lb/hr 1.31 kg/hr
<b>D30-051040</b> 	051040 # of Holes Diameter Disc Thickness	1.0 Rev./min 35.5 Rev./min (35.5 RPM)	4.24 g/Rev. 0.11 g/Hole	0.19 lb/hr 0.09 kg/hr	7.16 lb/hr 3.25 kg/hr		0.26 lb/hr 0.12 kg/hr	9.00 lb/hr 4.10 kg/hr
<b>Default Calibration # 4.00 g/rev</b>		0.2 Rev./min 6.4 Rev./min (6.4 RPM)		0.11 lb/hr 0.05 kg/hr	3.59 lb/hr 1.63 kg/hr	5.39g/Rev. 0.13 g/Hole	0.15 lb/hr 0.07kg/h	4.56 lb/hr 2.07 kg/h
		0.5 Rev./min 11.5 Rev./min (11.5 RPM)		0.27 lb/hr 0.12 kg/hr	6.33 lb/hr 2.87 kg/hr		0.35 lb/hr 0.15 kg/hr	8.00 lb/hr 3.62 kg/hr
		1.0 Rev./min 35.5 Rev./min (35.5 RPM)		0.55 lb/hr 0.25 kg/hr	19.80 lb/hr 9.00 kg/hr		0.70 lb/hr 0.32 kg/hr	25.30 lb/hr 11.50 kg/hr

**Note 1:** This guide is to be used for general disc selection for Digital Dosing unit applications. All rates shown are continuous throughput and are based on free-flowing materials. Consult factory for regrind, powder and all hard to flow materials.

**Note 2:** Maximum feeder disc revolutions in one screw recovery period (injection mode) is 9.5 revolutions. Use proper disc sizing for injection mode applications to ensure proper dispense of material during the recovery cycle. Maximum dispense during a recovery cycle should not exceed 9.5 revolutions of the metering disc.

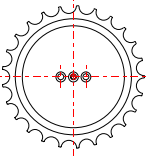
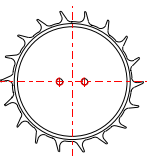
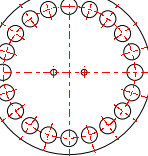
<b>D30-051725</b> 	051725 # of Holes Diameter Disc Thickness	<b>0.2 Rev./min</b> <b>6.4 Rev./min</b> <b>(6.4 RPM)</b>	7.37 g/Rev. 0.30 g/Hole	0.20 lb/hr 0.09 kg/hr	6.23 lb/hr 2.83 kg/h	9.38g/Rev. 0.38 g/Hole	0.24 lb/hr 0.11 kg/h	7.90 lb/hr 3.60 kg/h
		<b>0.5 Rev./min</b> <b>11.5 Rev./min</b> <b>(11.5 RPM)</b>	0.48 lb/hr 0.22 kg/hr	11.0 lb/hr 4.99 kg/hr	0.61 lb/hr 0.27 kg/hr	14.0 lb/hr 6.36 kg/hr		
		<b>1.0 Rev./min</b> <b>35.5 Rev./min</b> <b>(35.5 RPM)</b>	1.00 lb/hr 0.44 kg/hr	34.60 lb/hr 15.70 kg/hr	1.25 lb/hr 0.57 kg/hr	44.00 lb/hr 20.00 kg/hr		
		<b>Default Calibration #</b> <b>7.30 g/rev</b>						
<b>DD30 051818</b> 	051818 # of Holes Diameter Disc Thickness	<b>0.2 Rev./min</b> <b>6.4 Rev./min</b> <b>(6.4 RPM)</b>	13.42 g/Rev. 0.75 g/Hole	0.35 lb/hr 0.16 kg/hr	11.40 lb/hr 5.15 kg/hr	17.08 g/Rev. 0.95 g/Hole	0.44 lb/hr 0.20 kg/h	14.50 lb/hr 6.56 kg/h
		<b>0.5 Rev./min</b> <b>11.5 Rev./min</b> <b>(11.5 RPM)</b>	0.85 lb/hr 0.39 kg/hr	19.60 lb/hr 8.89 kg/hr	1.12 lb/hr 0.51 kg/hr	25.63 lb/hr 11.62 kg/hr		
		<b>1.0 Rev./min</b> <b>35.5 Rev./min</b> <b>(35.5 RPM)</b>	1.76 lb/hr 0.80 kg/hr	63.00 lb/hr 28.60 kg/hr	2.20 lb/hr 1.00 kg/hr	80.25 lb/hr 36.40 kg/hr		
		<b>Default Calibration #</b> <b>13.50 g/rev</b>						
<b>DT30 101820</b> 	101820 # of Holes Diameter Disc Thickness	<b>0.2 Rev./min</b> <b>6.4 Rev./min</b> <b>(6.4 RPM)</b>	28.00 g/Rev. 1.40 g/Hole	0.75 lb/hr 0.34 kg/hr	23.70 lb/hr 10.75 kg/hr	35.63 g/Rev. 1.78 g/Hole	1.00 lb/hr 0.43 kg/h	30.10 lb/hr 13.68 kg/h
		<b>0.5 Rev./min</b> <b>11.5 Rev./min</b> <b>(11.5 RPM)</b>	1.85 lb/hr 0.84 kg/hr	42.23 lb/hr 19.15 kg/hr	2.31 lb/hr 1.05 kg/hr	52.78 lb/hr 23.94 kg/hr		
		<b>1.0 Rev./min</b> <b>35.5 Rev./min</b> <b>(35.5 RPM)</b>	3.7 lb/hr 1.68 kg/hr	131.50 lb/hr 59.70 kg/hr	4.70 lb/hr 2.14 kg/hr	167.30 lb/hr 75.90 kg/hr		
		<b>Default Calibration #</b> <b>28.00 g/rev</b>						

**Note 1:** This guide is to be used for general disc selection for Digital Dosing unit applications. All rates shown are continuous throughput and are based on free-flowing materials. Consult factory for regrind, powder and all hard to flow materials.

**Note 2:** Maximum feeder disc revolutions in one screw recovery period (injection mode) is 9.5 revolutions. Use proper disc sizing for injection mode applications to ensure proper dispense of material during the recovery cycle. Maximum dispense during a recovery cycle should not exceed 9.5 revolutions of the metering disc.

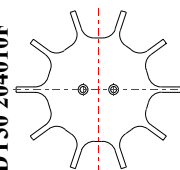

DT30-102025 Sure-Shot disc No Picture	P102025 # of Holes Diameter Disc Thickness	0.2 Rev./min 6.4 Rev./min (6.4 RPM)	33.60 g/Rev. 1.3 g/Hole	0.87 lb/hr 0.40 kg/hr	27.94 lb/hr 12.67 kg/hr	42.75 g/Rev. 1.71 g/Hole	1.12 lb/hr 0.50 kg/h	35.56 lb/hr 16.12 kg/h
		0.5 Rev./min 11.5 Rev./min (11.5 RPM)		2.18 lb/hr 0.99 kg/hr	49.77 lb/hr 22.57 kg/hr		2.77 lb/hr 1.26 kg/hr	63.34 lb/hr 28.72 kg/hr
Default Calibration # 33.00 g/rev	203012 # of Holes Diameter Disc Thickness	1.0 Rev./min 35.5 Rev./min (35.5 RPM)		4.36 lb/hr 1.98 kg/hr	154.90 lb/hr 70.29 kg/hr		5.55 lb/hr 2.52 kg/hr	197.25 lb/hr 89.46 kg/hr
		0.2 Rev./min 6.4 Rev./min (6.4 RPM)	95.09 g/Rev. 7.92 g/Hole	2.51 lb/hr 1.14 kg/hr	80.50 lb/hr 36.50 kg/hr	118.72 g/Rev. 9.89 Hole	3.13 lb/hr 1.42 kg/h	100.53 lb/hr 45.60 kg/h
Default Calibration # 95.00 g/rev	204010 # of Holes Diameter Disc Thickness	0.5 Rev./min 11.5 Rev./min (11.5 RPM)		6.28 lb/hr 2.85 kg/hr	143.28 lb/hr 65.00 kg/hr		7.80 lb/hr 3.54 kg/hr	178.00 lb/hr 80.71 kg/hr
		1.0 Rev./min 35.5 Rev./min (35.5 RPM)		12.50 lb/hr 5.70 kg/hr	446.54 lb/hr 202.50 kg/hr		15.65 lb/hr 7.10 kg/hr	557.55 lb/hr 252.90 kg/hr
DT30 204010F 	204010 # of Holes Diameter Disc Thickness	0.2 Rev./min 6.4 Rev./min (6.4 RPM)	151.15 g/Rev. 15.12 g/Hole	4.00 lb/hr 1.80 kg/hr	128.00 lb/hr 59.00 kg/hr	188.72 g/Rev. 18.87 Hole	5.00 lb/hr 2.25 kg/h	160.00 lb/hr 72.50 kg/h
		0.5 Rev./min 11.5 Rev./min (11.5 RPM)		10.00 lb/hr 4.53 kg/hr	227.74 lb/hr 103.28 kg/hr		12.43 lb/hr 5.64 kg/hr	283.54 lb/hr 129.00 kg/hr
Default Calibration # 150.00 g/rev	204010 # of Holes Diameter Disc Thickness	1.0 Rev./min 35.5 Rev./min (35.5 RPM)		20.00 lb/hr 9.00 kg/hr	705.00 lb/hr 320.00kg/hr		25.00 lb/hr 11.30 kg/hr	886.00 lb/hr 402.00 kg/hr
		0.2 Rev./min 6.4 Rev./min (6.4 RPM)						

**Note 1:** This guide is to be used for general disc selection for Digital Dosing unit applications. All rates shown are continuous throughput and are based on free-flowing materials. Consult factory for regrind, powder and all hard to flow materials.

**Note 2:** Maximum feeder disc revolutions in one screw recovery period (injection mode) is 9.5 revolutions. Use proper disc sizing for injection mode applications to ensure proper dispense of material during the recovery cycle. Maximum dispense during a recovery cycle should not exceed 9.5 revolutions of the metering disc.

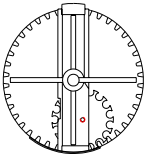
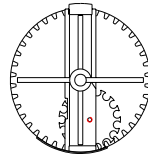
<b>DP30 050940</b> 	P050940 # of Holes Diameter Disc Thickness	<b>0.2 Rev./min</b> <b>6.4 Rev./min</b> <b>(6.4 RPM)</b>	15.64 g/Rev. 0.39 g/Hole	0.41 lb/hr 0.187 kg/hr	13.20 lb/hr 6.00 kg/hr	19.53 g/Rev. 0.49 g/Hole	0.51 lb/hr 0.23 kg/h	16.50 lb/hr 7.50 kg/h
		<b>0.5 Rev./min</b> <b>11.5 Rev./min</b> <b>(11.5 RPM)</b>	1.00 lb/hr 0.45 kg/hr	22.62 lb/hr 10.62 kg/hr	0.12 lb/hr 0.57 kg/hr	28.65 lb/hr 13.80 kg/hr		
<b>Default Calibration #</b> <b>15.00 g/rev</b>	<b>1.0 Rev./min</b> <b>35.5 Rev./min</b> <b>(35.5 RPM)</b>	2.00 lb/hr 0.94 kg/hr	73.40 lb/hr 33.30 kg/hr	2.60 lb/hr 1.17 kg/hr	91.70 lb/hr 41.60 kg/hr			
		<b>DP30 250940</b> 	P250940 # of Holes Diameter Disc Thickness	<b>0.2 Rev./min</b> <b>6.4 Rev./min</b> <b>(6.4 RPM)</b>	7.82 g/Rev. 0.20 g/Hole	0.20 lb/hr 0.093 kg/hr	13.2 lb/hr 3.00 kg/hr	9.76 g/Rev. 0.245 g/Hole
<b>Default Calibration #</b> <b>7.80 g/rev</b>	<b>0.5 Rev./min</b> <b>11.5 Rev./min</b> <b>(11.5 RPM)</b>	0.46 lb/hr 0.21 kg/hr	10.55 lb/hr 4.78 kg/hr	0.60 lb/hr 0.27 kg/hr	13.57 lb/hr 6.15 kg/hr			
		<b>1.0 Rev./min</b> <b>35.5 Rev./min</b> <b>(35.5 RPM)</b>	1.00 lb/hr 0.47 kg/hr	36.70 lb/hr 16.65 kg/hr	1.30 lb/hr 0.58 kg/hr	45.85 lb/hr 20.80 kg/hr		

**Note 1:** This guide is to be used for general disc selection for Digital Dosing unit applications. All rates shown are continuous throughput and are based on free-flowing materials. Consult factory for regrind, powder and all hard to flow materials.

**Note 2:** Maximum feeder disc revolutions in one screw recovery period (injection mode) is 9.5 revolutions. Use proper disc sizing for injection mode applications to ensure proper dispense of material during the recovery cycle. Maximum dispense during a recovery cycle should not exceed 9.5 revolutions of the metering disc.

# Specification Sheet

## DIGITAL DOSING UNIT TECHNICAL PARAMETERS

**Disc Dosing Factor Table 2**

Maximum Number of Feed Stations	One (1) for Granule Processing
Maximum Product Temperature	80°C (or 176°F)
Weight (Approximately)	20 kg (44 pounds)
Connected Loads	0.11 kW
Operating Voltage	115/1/60 or 230/1/50-60
Special Voltage	On Request
Option	Level Probe

### Digital Dosing unit parameter setup 7-14

		Bison - Black motor				Bauer - Blue motor				Comments
Parameter	RPM	2	6	12	38	6.4	11.5	35.5		
	7	65000	25200	14103	4387	11739	6600	2135	These values refer to the pulses of the encoder	
8		0.5				0.7				Nominal motor current
9		Ext	Inj			Ext	Inj			(see separate calculation sheet for parameter #9)
10		0				1				Factory set, do not change
11		Ext	Inj			Ext	Inj			
		50		50		50		50		Ext = minimum input frequency w/follower only
12		Ext	Inj			Ext	Inj			Inj = Minimum # of machine cycles per dosing
		10		5.56		10		5.56		Ext = Span factor (sf) calculated using: sf=1000/rpm@10vdc sf = 1000/rpm @20ma
13		Ext	Inj			Ext	Inj			
		0		0		0		0		Communication address used with Euromap 17 (use 1 instead of 0)
14		Ext	Inj			Ext	Inj			
		0		0		0		0		For use with Mico mix hopper (use 1 instead of 0)



# Station 1 Digital Dosing Unit

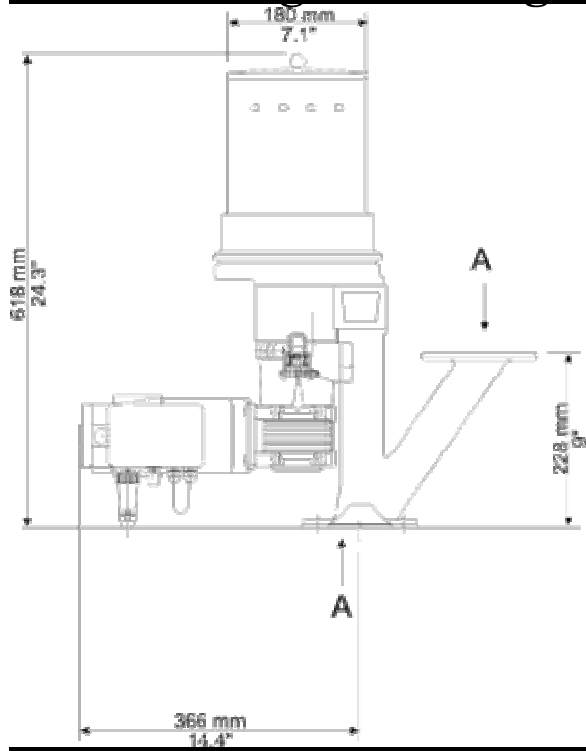

**SIDE VIEW**

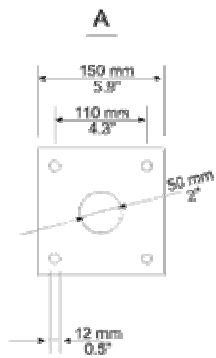

**TOP VIEW**

## Station 2 Digital Dosing Unit

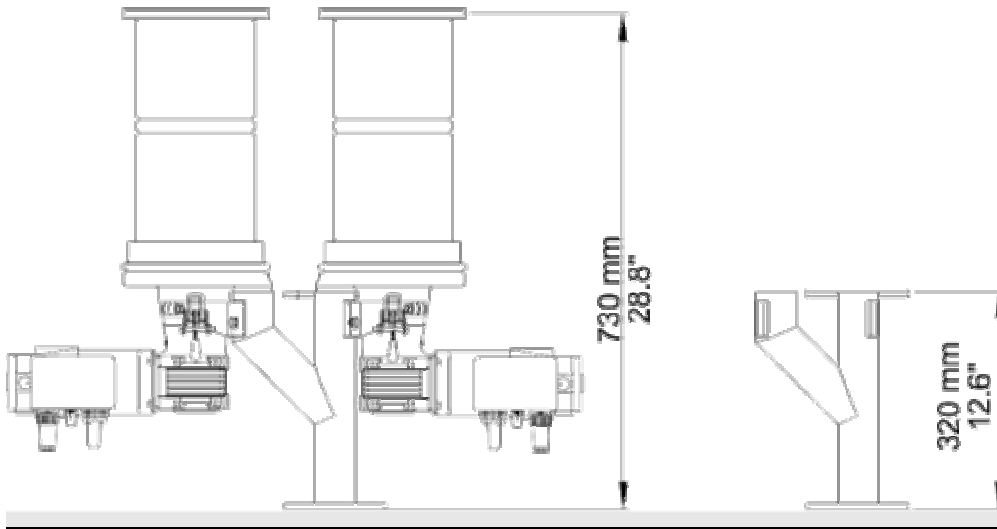

## SIDE VIEW

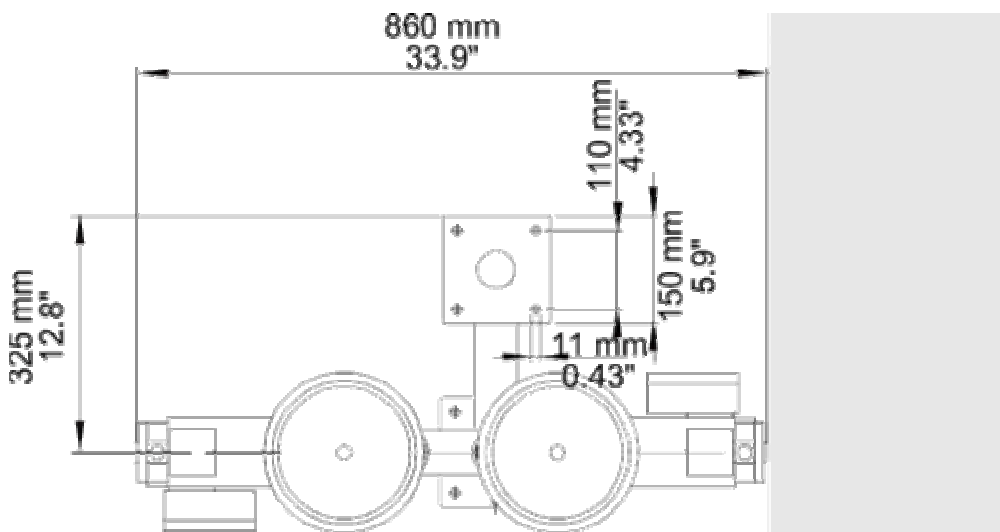

## TOP VIEW

### Dosing Unit Electrical Schematic Chart

Drawing No.	Description of Drawing	Voltage
CT102020	C150 CONTROLLER INJECTION	110
CT102021	C150 CONTROLLER EXT-S SIMPLE EXTRUSION	110
CT102022	C150 CONTROLLER EXT-V EXTRUSION 0-10 V INPUT	110
CT102023	C150 CONTROLLER EXT-C EXTRUSTION 0-20 mA INPUT	110
CT102024	C150 CONTROLLER INJECTION	220
CT102025	C150 CONTROLLER EXT-S EXTRUSION SIMPLE EXTRUSION	220
CT102026	C150 CONTROLLER EXT-V EXTRUSION 0-10 V INPUT	220
CT102027	C150 CONTROLLER EXT-C EXTRUSION 0-20 mA INPUT	220

**Note:**

- 1. If changes to the controller are required, please consult factory.***
- 2. Request any additional drawings needed at that time.***



# Appendix D: Spare Parts List

## Dosing Disc/Shear Order Numbers

Dosing disc	
72 chambers	ID 100562
49 chambers	ID 21710
25 chambers	ID 21711
18 chambers	ID 2057
Dosing disc, wear-resistant	
40 chambers	ID 28214
25 chambers	ID 27141
18 chambers	ID 27142
Shear for DD style unit	
18, 25, 40 pocket disc	ID 21392
72 pocket disc	ID 100875
Shears	
Standard	ID 21392
72 chamber only	ID100875

## Control System Order Numbers

Fuse	
F1 / F7, 5 AT	84773
F2, 4 AF	84770
F3, 0,5 AF	83670
F4 / F5, 2 AT	99815

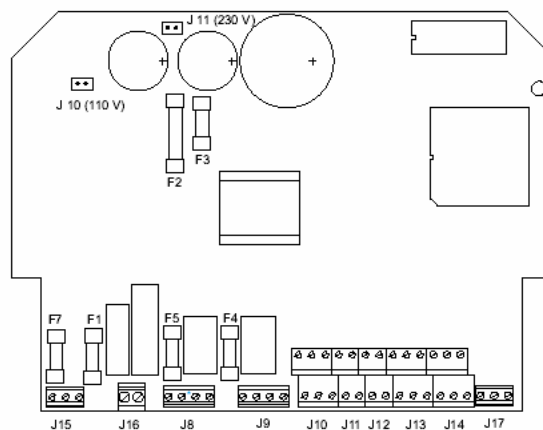

**-Notes-**

# **Technical Assistance**

## **Parts Department**

Call toll-free 7am–5pm CST [800] 423-3183 or call [630] 595-1060, Fax [630] 475-7005  
The ACS Customer Service Group will provide your company with genuine OEM quality parts manufactured to engineering design specifications, which will maximize your equipment's performance and efficiency. To assist in expediting your phone or fax order, please have the model and serial number of your unit when you contact us. A customer replacement parts list is included in this manual for your convenience. ACS welcomes inquiries on all your parts needs and is dedicated to providing excellent customer service.

## **Service Department**

Call toll-free 8am–5pm CST [800] 233-4819 or call [630] 595-1060  
Emergencies after 5pm CST, call [847] 439-5655  
We have a qualified service department ready to help. Service contracts are available for most products.

## **Sales Department**

Call [630] 595-1060 Monday–Friday, 8am–5pm CST  
Our products are sold by a worldwide network of independent sales representatives. Contact our Sales Department for the name of the sales representative nearest you.

## **Contract Department**

Call [630] 595-1060 Monday–Friday, 8am–5pm CST  
Let us install your system. The Contract Department offers any or all of these services: project planning; system packages including drawings; equipment, labor, and construction materials; and union or non-union installations.

ACS Group  
800 Wood Dale Road  
Wood Dale, IL 60191

## Free Manuals Download Website

<http://myh66.com>

<http://usermanuals.us>

<http://www.somanuals.com>

<http://www.4manuals.cc>

<http://www.manual-lib.com>

<http://www.404manual.com>

<http://www.luxmanual.com>

<http://aubethermostatmanual.com>

Golf course search by state

<http://golfingnear.com>

Email search by domain

<http://emailbydomain.com>

Auto manuals search

<http://auto.somanuals.com>

TV manuals search

<http://tv.somanuals.com>