

USER'S MANUAL

WiConnect

Wireless Subwoofer



Velodyne[®]

Enjoy.

Thank you for choosing a Velodyne. Our passion for high performance, low-distortion bass is the driving force behind our worldwide reputation in audio and technical innovation.

We are pleased to bring the Velodyne sound experience to your home.

IMPORTANT SAFETY INSTRUCTIONS



Caution

To reduce the risk of electric shock, do not remove cover (or back). No user-serviceable parts inside. Refer servicing to qualified service personnel.

The lightning flash with arrowhead symbol is intended to alert the user to the presence of uninsulated “dangerous voltage” within the product’s enclosure that may be of sufficient magnitude to constitute a risk of electric shock to persons.

The exclamation point symbol is intended to alert the user to the presence of important operating and maintenance (servicing) instructions in the literature accompanying the subwoofer.

1. **Read Instructions** — All safety and operating instructions should be read before the product is operated.
2. **Retain Instructions** — The safety and operating instructions should be retained for future reference.
3. **Heed Warnings** — All warnings on the product and in the operating instructions should be adhered to.
4. **Follow Instructions** — All operating and use instructions should be followed.
5. **Water and Moisture** — The product should not be used near water — for example, near a bathtub, washbowl, kitchen sink, laundry tub, in a wet basement, near a swimming pool or the like.
6. **Carts and Stands** — The product should be used only with a cart or stand recommended by the manufacturer.
7. **Wall or Ceiling Mounting** — The product should be mounted to a wall or ceiling only as recommended by the manufacturer.
8. **Ventilation** — The product should be situated so that its location or position does not interfere with its proper ventilation. For example, the product should not be situated on a bed, sofa, rug, or similar surface that may block the ventilation openings; or placed in a built-in installation such as a bookcase or cabinet that may impede the flow of air through the ventilation openings.
9. **Heat** — The product should be situated away from heat sources such as radiators, heat registers, stoves, or other products that produce heat.
10. **Power Sources** — The product should be connected to a power supply only of the type described in the operating instructions or as marked on the product.
11. **Grounding or Polarization** — This product may be equipped with a polarized alternating-current line plug (a plug having one blade wider than the other). This plug will fit into the power outlet only one way. This is a safety feature. If you are unable to insert the plug fully into the outlet, try reversing the plug. If the plug should still fail to fit, contact your electrician to replace your obsolete outlet. Do not defeat the safety purpose of the polarized plug.
12. **Power-Cord Protection** — Power-supply cords should be routed so that they are not likely to be walked on or pinched by items placed upon or against them, paying particular attention to cords at plugs, convenience receptacles, and the point at which they exit from the product.
13. **Cleaning** — The product should be cleaned only as recommended by the manufacturer.
14. **Nonuse Periods** — The power cord of the product should be unplugged from the outlet when left unused for a long period of time.
15. **Object and Liquid Entry** — Care should be taken so that objects do not fall and liquids are not spilled onto the enclosure.
16. **Damage Requiring Service** — The product should be serviced by qualified service personnel when:
 - a. The power-supply cord or plug has been damaged.
 - b. Objects have fallen or liquid has been spilled into the product.
 - c. The product has been exposed to rain.
 - d. The product does not appear to operate normally or exhibits a marked change in performance.
 - e. The product has been dropped or damaged.
17. **Servicing** — The user should not attempt to service the product beyond what is described in the operating instructions. All other servicing should be referred to qualified service personnel. Refer all servicing to qualified service personnel. Servicing is required when the apparatus has been damaged in any way, such as a power-supply cord or plug is damaged, liquid has been spilled or objects have fallen into the apparatus, the apparatus has been exposed to rain or moisture, does not operate normally, or has been dropped.
18. **Lightning** — For added protection for the product during a lightning storm or when it is left unattended and unused for long periods of time, unplug it from the wall outlet.
19. **Overloading** — Do not overload wall outlets, extension cords or integral convenience receptacles as this can result in a risk of fire or electric shock.
20. **Attachments** — Only use attachments and accessories specified by the manufacturer.
21. **Voltage** — Insure that the subwoofer is only connected to the rated source voltage. Do not connect the 120-volt version to 230-volts or vice-versa. This will result in damage to the subwoofer and possible injury to the user.

CAUTION: To prevent electrical shock, match wide blade of plug to wide slot, fully inserted.

TABLE OF CONTENTS

SETUP

Place Subwoofer	1
Subwoofer Placement Guidelines	2
Subwoofer Placement Cautions	2
Box Contents	3
Connect Wireless Transmitter to Receiver	5
Select Receiver Options Optimal Subwoofer Performance	7
Connect Subwoofer	8
Select Wireless Broadcast Channel	8
— Wireless Broadcast Considerations	8
Adjust Subwoofer Controls for Listening Preferences	9
Adjust Subwoofer Location for Listening Preferences	9
— Crawl Test	9
— Move Test	10
Connect Multiple Wireless Subwoofers	10
— In a Single Audio System	10
— In Separate Audio Systems	10
Use the Subwoofer's LFE Input (Optional)	11
Mount Wireless Transmitter on Wall (Optional)	12

MAINTAIN

Protect Subwoofer from Damage	13
Clean	13
Service	13
Troubleshoot	14
Packaging	14

RESOURCES

Specifications	15
Protection Circuitry	15
Regulatory Information	16
— FCC Compliance Statement	16
— FCC Warning	16
— European Union (EU) Declaration of Conformity	16
Radio Frequency Exposure Limit Requirements	16
Listen Responsibly	16
Legal Notice	16
— Subwoofer Recycling	16
— Trademarks	16
Warranty	17

SET UP

Place Subwoofer

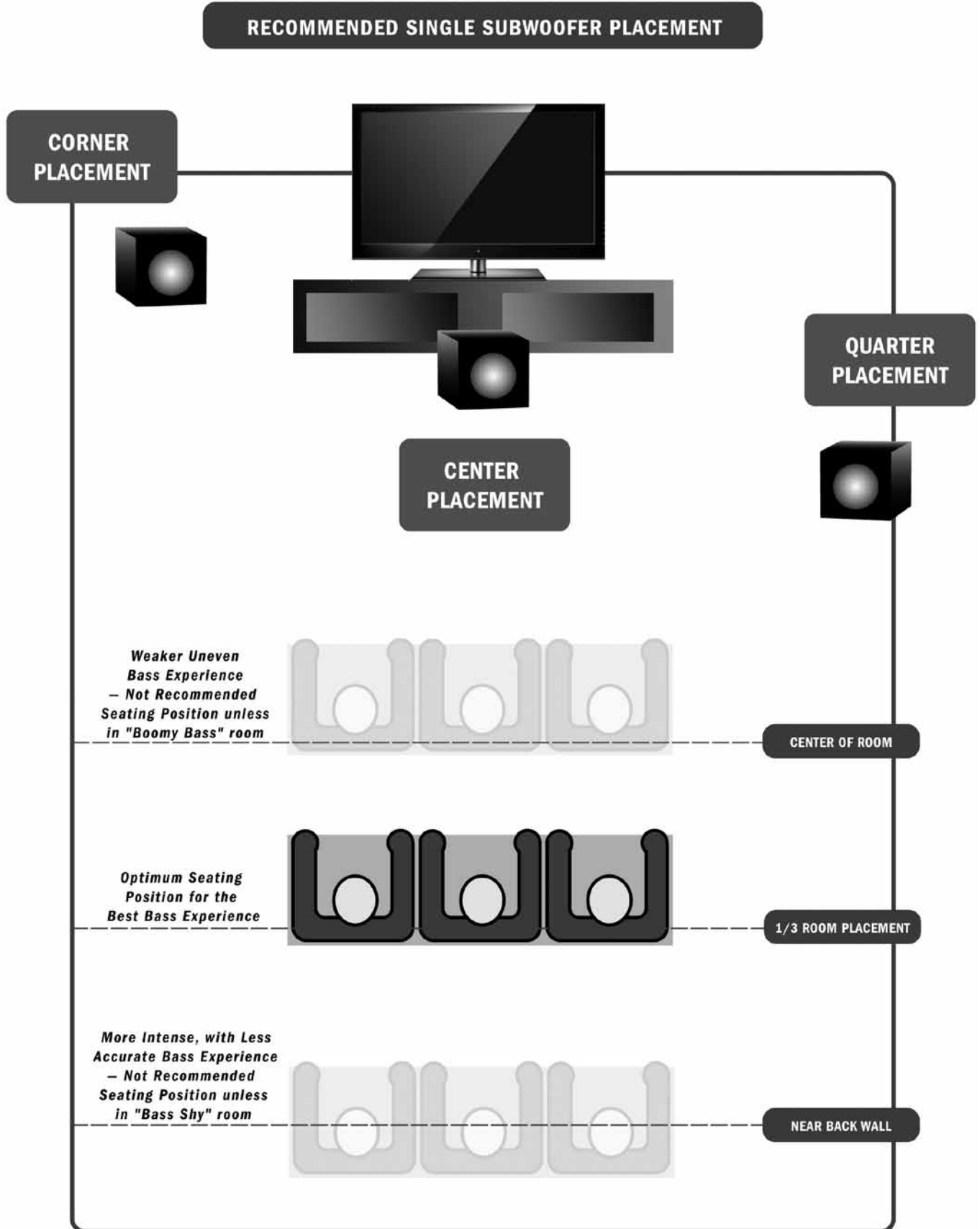

1. Review the **Placement Guidelines** section below.
2. Review the **Placement Cautions** section below.
3. Select a subwoofer placement location based on the placement cautions and guidelines.
4. Before you remove the subwoofer from the box, place the box near where you want to place the subwoofer in your room. If you've already unpacked the subwoofer, move the subwoofer to where you want it in the room.
NOTE: Later, we'll guide you to optionally adjust the location of the subwoofer for your listening preferences.
5. Go to the **Box Contents** section next.

The seating positions shown in the diagram above are general guidelines for most room types and aren't dependent on the subwoofer placement. Sitting closer to the front in a "boomy bass" room may sound better. Sitting closer to the back of a "bass shy" room may sound better.

Subwoofer Placement Guidelines

REFER to the RECOMMENDED SINGLE SUBWOOFER PLACEMENT diagram above for general seating and subwoofer placement guidelines.

PLACE in a CORNER (loudest) or within a FEW FEET of a WALL (smoothest). AVOID locations FAR AWAY from a WALL, CLOSE to the ROOM CENTER, BY a DOOR, NEAR a PARTIAL-HEIGHT WALL, or BEHIND SEATING ARRANGEMENTS. FACE the GRILLE TOWARDS the room's main SEATING location.

MAKE SURE:

- You can access the controls on the rear of the subwoofer.
- The included 6' power cord for the subwoofer can safely reach a power outlet.

Subwoofer Placement Cautions

PLACE THE SUBWOOFER CABINET ON A STABLE, FLAT AND LEVEL SURFACE. An uneven or unstable surface can cause the subwoofer to tip over and cause injury or be damaged. Protruding objects from the surface or an uneven surface could cause damage to the speaker cone on the bottom of the cabinet.

DO NOT CREATE A TRIP HAZARD WITH THE POWER CORDS. Route power cables so that they cannot be tripped on by persons walking in the room.

DO NOT BLOCK THE SOUND PORT. The sound port is located in the back of the cabinet above the cable connection sockets.

PLACE THE SUBWOOFER ON THE FLOOR. If the subwoofer is placed on a stand, bracket, tripod, table or similar device, it could fall or be knocked over causing injury to persons or damage to the subwoofer and other items.

KEEP THE SUBWOOFER IN ITS UPRIGHT POSITION.

Box Contents

Now that you've unpacked the subwoofer, make sure you have the components and Velodyne supplied accessories shown below. Also, acquire the necessary user supplied accessories. If any components or Velodyne supplied accessories are missing or damaged, contact the retailer where you purchased this subwoofer.



Subwoofer



Wireless Transmitter

Velodyne Supplied Accessories

- 6' Power cord for subwoofer.
- 5V DC power adaptor for wireless transmitter.
- Self-tapping wood screws (2) for wireless transmitter mounting.

User Supplied Accessories

- RCA cable for connecting wireless transmitter to receiver, or if using the wired instead of the wireless connection option, RCA cable for connecting subwoofer to wireless transmitter.

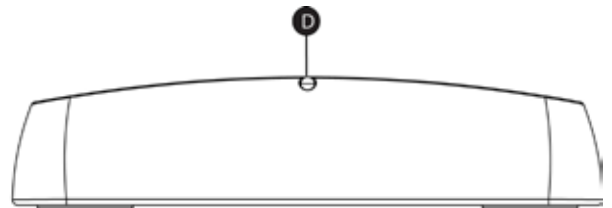
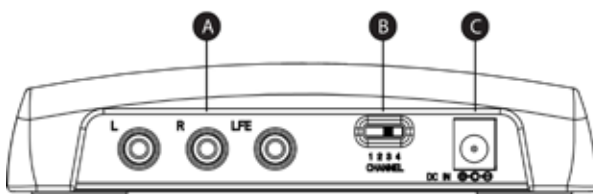

A. INPUTS

- L and R: Inputs for connecting to the receiver's RCA outputs.
- LFE: Input for connecting to the receiver's LFE output.

B. CHANNEL: Selection switch for choosing broadcast frequency. This CHANNEL selection must match CHANNEL selection on the subwoofer.

C. 5V DV Power adaptor socket

D. BLUE LED: Indicates transmitter is active.

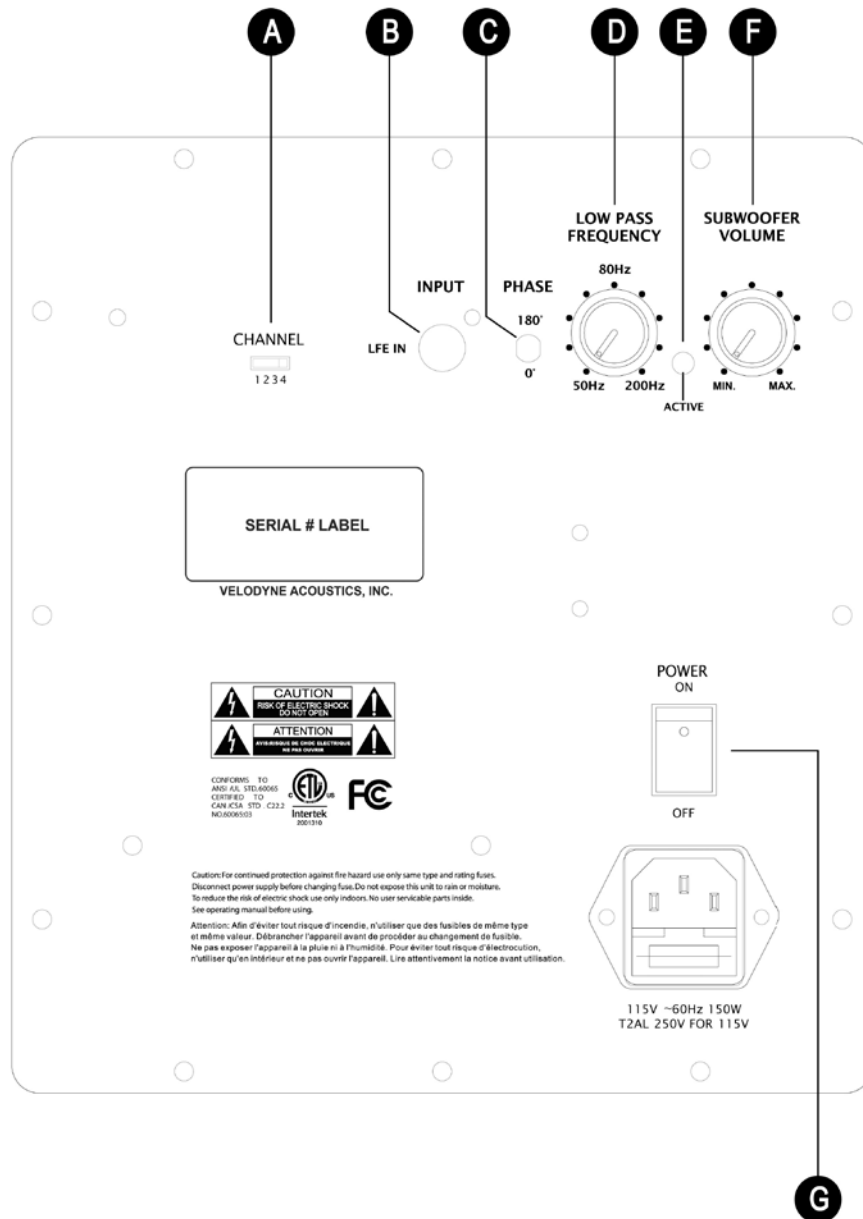

- A. **CHANNEL:** Select broadcast frequency. This CHANNEL selection must match CHANNEL selection on the transmitter.
- B. **LFE INPUT:** Optional wired connection to receiver, if not using the wireless connection.
- C. **PHASE:** Invert the phase of the subwoofer, if it blends better with the satellite speakers.
- D. **LOW-PASS CROSSOVER:** Select the upper frequency to cut-off the audio signal to the subwoofer output.
- E. **ACTIVE:**
- Solid yellow when ON/ACTIVE using wireless connection.
 - Flashing yellow and green when ON/ACTIVE , but no RF signal.
 - Solid Red when in ON/STAND BY.
 - Subwoofer goes to STAND BY if no audio signal is present for 12 minutes.
- F. **VOLUME:** Adjust subwoofer volume.
- G. **POWER:** Switch power ON and OFF.

Connect Wireless Transmitter to Receiver

Use one of the following two setups to connect the wireless transmitter to receiver:

SETUP #1: MOST COMMON (RECEIVER LFE/SUB OUTPUT) This setup requires one RCA cable

SETUP #2: LESS COMMON (NO RECEIVER LFE/SUB OUTPUT) This setup requires one RCA cable for each of the L and R channels.

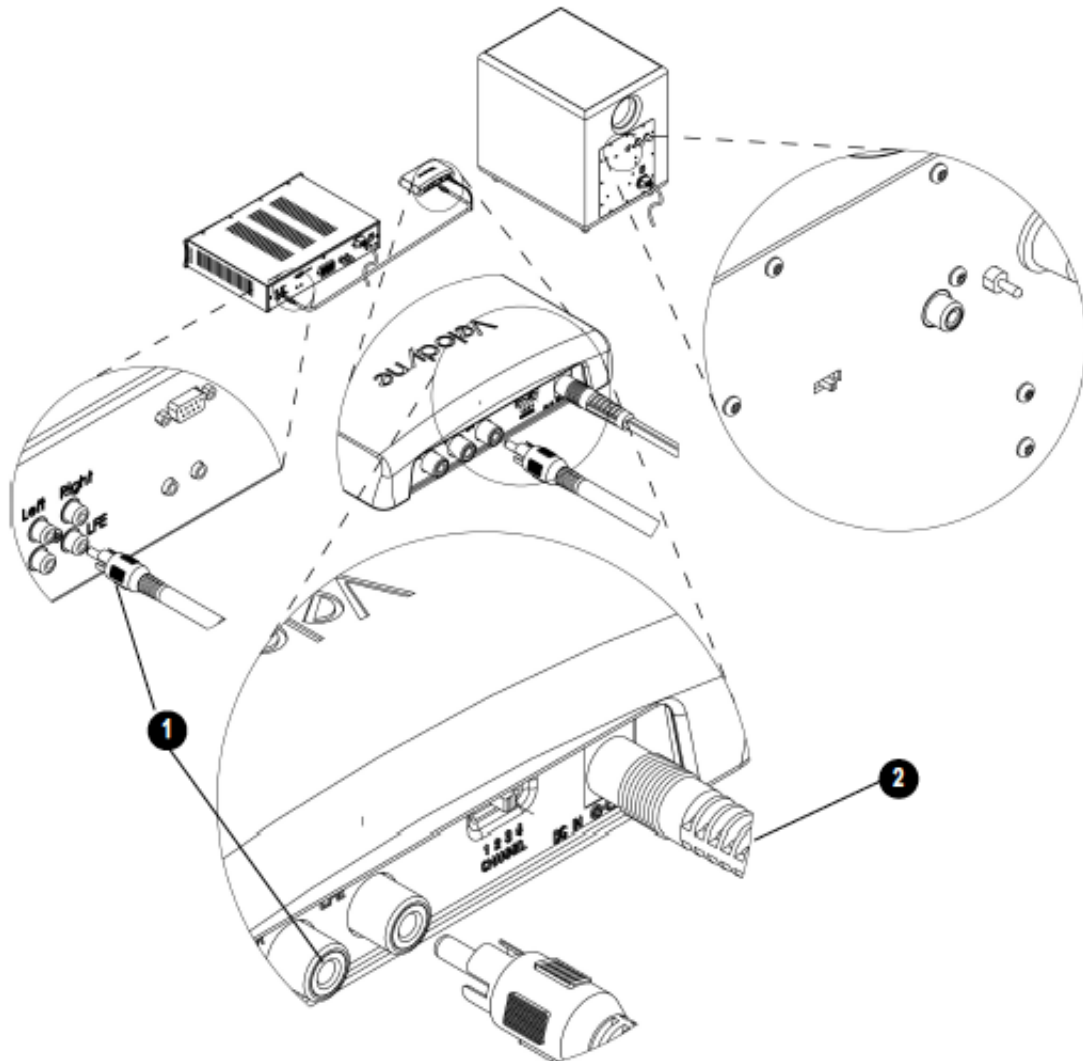

SETUP #1: MOST COMMON (RECEIVER HAS LFE/SUB OUTPUT)

1. **Use** the RCA cable supplied by you to connect the wireless transmitter's LFE input to your receiver's LFE or SUB output.
2. **Plug** the wireless transmitter's 5V DC power adaptor into the back of the wireless transmitter. Plug the other end of the adaptor into a power outlet.
3. **Go** to the **Select Receiver Options for Optimal Subwoofer Performance** instructions next.

NOTE: The subwoofer must be within 50 feet (15 meters) from its transmitter to be able to receive the wireless signal. Also, make sure that the same CHANNEL is selected on both the transmitter and subwoofer.

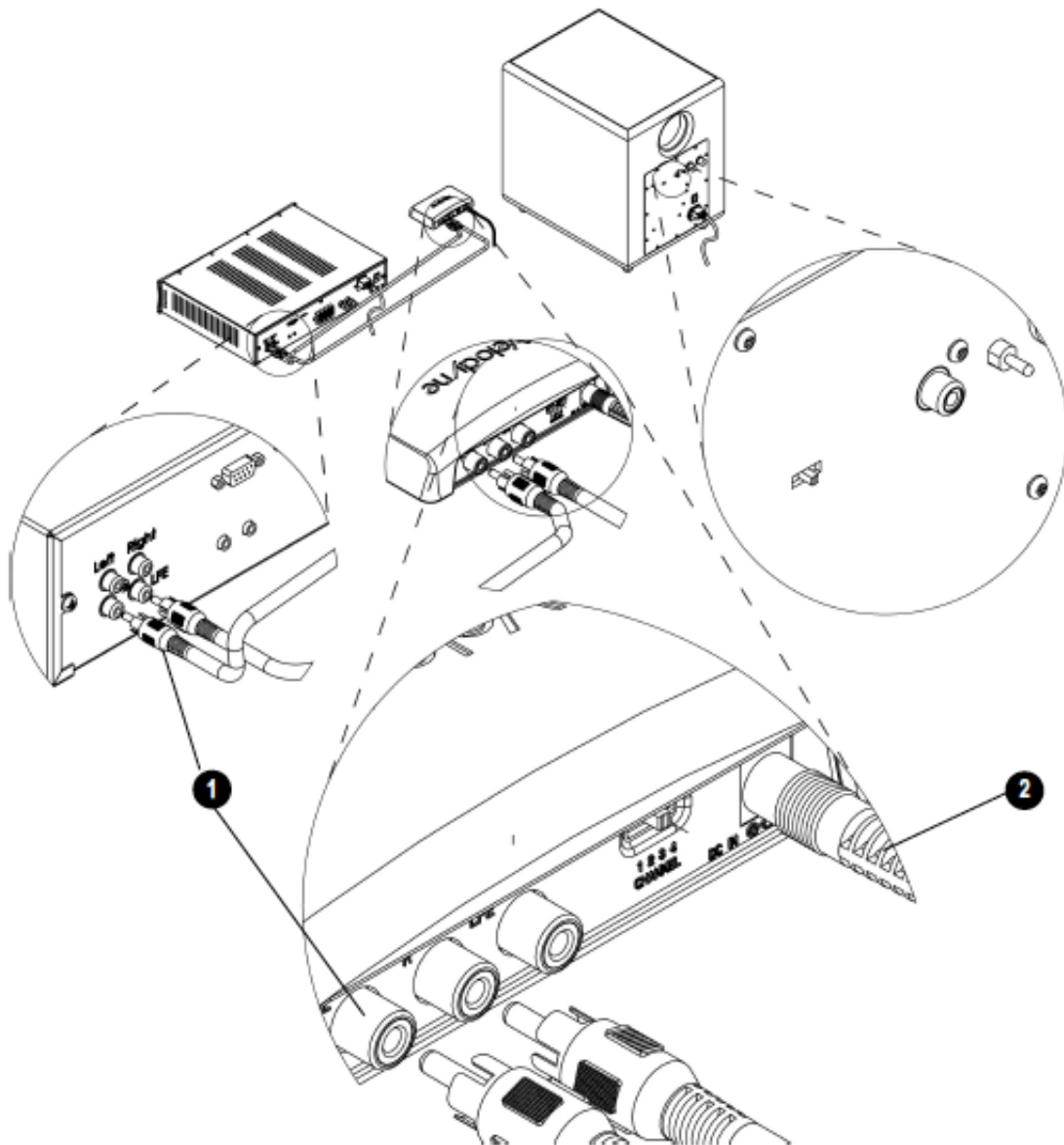

SETUP #2: LESS COMMON (RECEIVER HAS NO LFE/SUB OUTPUT)

1. **Use** the two RCA cables supplied by you to connect the wireless transmitter's R and L inputs to your receiver's R and L outputs.
2. **Plug** the wireless transmitter's 5V DC power adaptor into the back of the wireless transmitter. Plug the other end of the adaptor into a power outlet.
3. **Go** to the **Select Receiver Options for Optimal Subwoofer Performance** instructions next.

NOTE: The subwoofer must be within 50 feet (15 meters) from its transmitter to be able to receive the wireless signal. Also, make sure that the same CHANNEL is selected on both the transmitter and subwoofer.

Select Receiver Options Optimal Subwoofer Performance

It is important that the audio system's existing receiver is set up correctly to work in concert with the subwoofer. To set up the receiver refer to its instruction manual and use one of the following three options:

RECEIVER OPTIONS:	OPTION #1 (MOST COMMON)	OPTION# 2 (LESS COMMON)	OPTION #3 (LESS COMMON)
Wireless Transmitter SETUP	SETUP #1: (MOST COMMON)	SETUP #2: (LESS COMMON)	SETUP #3: (LESS COMMON)
Receiver has LFE or SUB output	Yes	Yes	No
Use receiver's LFE or SUB output as subwoofer's input	Yes	No	No
Use receiver's unfiltered/full frequency range R and L outputs as subwoofer's inputs	No. This setup uses the receiver's, not the subwoofer's, lowpass crossover frequency filter.	Yes. This setup uses the subwoofer's lowpass crossover frequency filter instead of the receiver's filter.	Yes . This setup uses the subwoofer's lowpass crossover frequency filter.

RECEIVER OPTION #1

The receiver's LFE or SUB output is the input to the subwoofer (most common case):

1. Select that you have a subwoofer.
2. Select the number of speakers.
3. Select the speaker size as SMALL.
4. If you don't know the low frequency limit of your main speakers, use 80 Hz as the crossover point. The lower limit of the main speaker's frequency response is usually listed in the speaker specifications as, for example, "3 dB down at 45 Hz."

In this example, double the value (45 Hz) and use the doubled-value (90 Hz) as the crossover frequency.

5. Adjust the LFE /SUB output level to 0 dB.
6. Go to the Connect Subwoofer instructions next.

RECEIVER OPTION #2

The receiver's unfiltered/full frequency range R and L output channels, not its LFE or SUB output, is the input to the subwoofer (less common case).

1. Select that you have NO subwoofer.
2. Select the number of speakers.
3. Select the speaker size as LARGE.
4. If the crossover frequency option is available, double your main speakers specified low frequency response value and select the result as the crossover frequency. If you don't know the low frequency response value, use 80 Hz.
5. Go to the Connect Subwoofer instructions next.

RECEIVER OPTION #3

The receiver has no LFE or SUB output:

1. No selections to make.
2. Go to the Connect Subwoofer instructions next.

Connect Subwoofer

1. Use the included power cord to connect the subwoofer to a power outlet.
2. Turn the POWER switch to the ON position. The ACTIVE light should be yellow.

NOTE: After 12 minutes without receiving a signal, the ACTIVE light turns red to indicate STAND BY mode. The subwoofer will automatically go from STAND BY mode to ACTIVE when it detects an audio signal.

3. Turn the VOLUME knob to MIN to prevent blasting music when you first use the subwoofer. You can increase the VOLUME to the correct level later.
4. You're done. No more wires to connect!
5. Go to the **Select Wireless Broadcast Channel** instructions next.

Select Wireless Broadcast Channel

The wireless transmitter can broadcast your audio signals on one of four selectable channels. Multiple channels are made available in case other devices in your home are using some of the channels for communication.

To select the broadcast channel:

1. Review the **Wireless Broadcast Considerations** below.
2. Use the CHANNEL switch on the back of the wireless transmitter to select "1", "2", "3", or "4" as the broadcast channel.
3. Use the CHANNEL switch on the back of the subwoofer to select the same broadcast channel as you selected on the wireless transmitter.
4. Go to the **Adjust Subwoofer Controls for Listening Preferences** instructions next.

Wireless Broadcast Considerations

All wireless devices like the WiC-10 may be susceptible to radio frequency (RF) interference from other devices. Other RF devices include WiFi Internet access, computer equipment and routers; WiFi solar panel monitoring systems; video game consoles, cordless telephones, blue tooth devices, baby monitors and microwave ovens. In particular, any devices operating in the 2.4 GHz band may cause intermittent wireless connections between the wireless transmitter and subwoofer.

To prevent wireless broadcast interference problems, keep wireless devices at least 2' apart. Any interference effects from a microwave oven will cease once the oven stops operating and may be resolved on a long-term basis by increasing the physical distance between the subwoofer and the microwave oven.

If the WiC-10 sound is intermittent, check that another wireless device isn't within 2' of either the wireless transmitter or the subwoofer.

Adjust Subwoofer Controls for Listening Preferences

Now it's time to adjust the subwoofer controls to match your listening environment and preferences.

1. Play some music through your receiver.
2. Turn the subwoofer's VOLUME to a level that balances with the output volume of your satellite speakers and doesn't distort the bass sounds. You might also want to adjust your receiver's LFE output volume higher, if you can't get a loud enough subwoofer output, or lower, if the subwoofer output is too loud.
3. If you didn't use the LFE INPUT on the wireless transmitter, optionally, adjust the subwoofer's LOW PASS FREQUENCY to provide a wireless transmitter input equivalent to an LFE input. The LOW PASS FREQUENCY is the frequency at which the subwoofer's output starts to decrease as the frequency increases. Your satellite speakers output the frequencies not covered by the subwoofer. You want to not be able to hear the transition from the subwoofer output to your satellite speakers' output. You can adjust this frequency from between 50 Hz to 200 Hz. To adjust this frequency:
 - a. If your satellite speakers are small with limited low frequency output, choose a LOW PASS FREQUENCY of between 100 Hz and 120 Hz.
 - b. If your satellite speakers are larger with better low frequency output, choose a LOW PASS FREQUENCY of around 80 Hz.
 - c. Adjust the LOW PASS FREQUENCY based on listening to your audio system until it sounds pleasing to your ear.
4. Optionally, switch the subwoofer's PHASE to 180°. This reverses the phase of the subwoofer to correct for sound cancellations between your subwoofer and your satellite speakers. To determine which PHASE is best for your room and subwoofer location:
 - a. Listen to the system with music playing.
 - b. Ask a friend to switch the PHASE switch from 0° to 180° while you listen for a change in the mid-bass loudness.
 - c. The correct PHASE is the one that you hear as having louder mid-bass.
 - d. If you can't tell a difference, keep the phase at 0°.
5. Go to the Adjust Subwoofer Location for Listening Preferences instructions next.

Adjust Subwoofer Location for Listening Preferences

Optionally, you can now optimize the location of the subwoofer for your listening preferences by either using the "Crawl Test" or the "Move Test."

Crawl Test

In this test, the subwoofer stays in one spot and you move around the room to different listening spots. To do the "Crawl Test":

1. Place the subwoofer on the floor or table near your most often used seating location. Velodyne doesn't recommend placing the subwoofer on the actual seating surface. The weight of the subwoofer or its corners could damage the seating surface or structure. Also, placing the subwoofer on a very soft surface, such as a sofa cushion, will not allow the downward firing speaker cone to extend out freely without hitting the surface and causing damage to the speaker.
2. Play some music on the audio system.
3. Crawl around to various spots in the room until you hear the best sounding bass output to you. When you hear the best bass output, you have determined the placement of the subwoofer for your listening preferences.
4. Re-locate the subwoofer from the seating location to the spot you crawled to that sounded the best.
5. You're done with this best placement test and setting up the subwoofer. Enjoy!

Move Test

In this test, you stay in one listening spot and you move the subwoofer around the room. To do the “Move Test”:

1. Place the subwoofer in a new location in the room.
2. Sit in the seating location you use most often.
3. Play some music on the audio system.
4. Listen to the audio output.
5. Repeat Step 1 through Step 4 until you hear the best sounding bass output to you. When you hear the best bass output, you have determined the placement of the subwoofer for your listening preferences.
6. You’re done with this best placement test and setting up the subwoofer. Enjoy!

Connect Multiple Wireless Subwoofers

In a Single Audio System

If you are using more than one wireless subwoofer in a single audio system, the following two setup options exist.

OPTION #1: All subwoofers receive the same audio signal. This is the most common setup. For this setup:

1. Connect only one wireless transmitter to your receiver. Follow the instructions for **OPTION #1** or **OPTION #2** in the **Connect Wireless Transmitter Section**.
2. Follow the instructions for **SETUP #1** in the **Select Receiver Options for Optimal Subwoofer Performance** section.
3. Set the same wireless broadcast channel on the wireless transmitter and all subwoofers. Follow the instructions in the **Select Wireless Broadcast Channel** section.
4. Follow the instructions in the **Adjust Subwoofer Controls** section for each subwoofer.

OPTION #2: Subwoofers receive different audio signals. This is a less common setup. Usually, this setup uses one subwoofer for the R audio channel and one subwoofer for the L audio channel. If using separate R and L channel subwoofers, place each subwoofer within a couple of feet of the appropriate main speaker for the channel. If the system’s crossover frequency is high, each subwoofer should be even closer to its channel’s main speaker. For this setup:

1. Connect a wireless transmitter to each signal you want to transmit to a subwoofer. Usually, one for the R and one for the L channel. Follow instructions for **SETUP #2** in the **Connect Wireless Transmitter Section**, except pair one transmitter’s R input to the R channel receiver output and the other transmitter’s L channel input to the L channel receiver output.
2. Follow the instructions for **OPTION #3** in the **Select Receiver Options for Optimal Subwoofer Performance** section.
3. Follow the instructions in the **Select Wireless Broadcast Channel** section, except:
 - a. Select a unique wireless broadcast channel for each wireless transmitter.
 - b. Match the wireless broadcast channel on each subwoofer to that of the wireless transmitter that broadcasts the audio signal the subwoofer is to output.
4. Follow the instructions in the **Adjust Subwoofer Controls** section for each subwoofer.

In Separate Audio Systems

If you have multiple audio systems in your home, such as one in the family movie room and another in a bedroom or office, you can use a separate wireless transmitter in each system. In this case, use a different wireless broadcast channel for each system, to avoid the subwoofers from getting input from multiple systems due to the close proximity of the systems.

Use the Subwoofer's LFE Input (Optional)

In case you misplace the wireless transmitter or the wireless transmitter malfunctions, you can also connect the subwoofer to your receiver with an RCA cable.

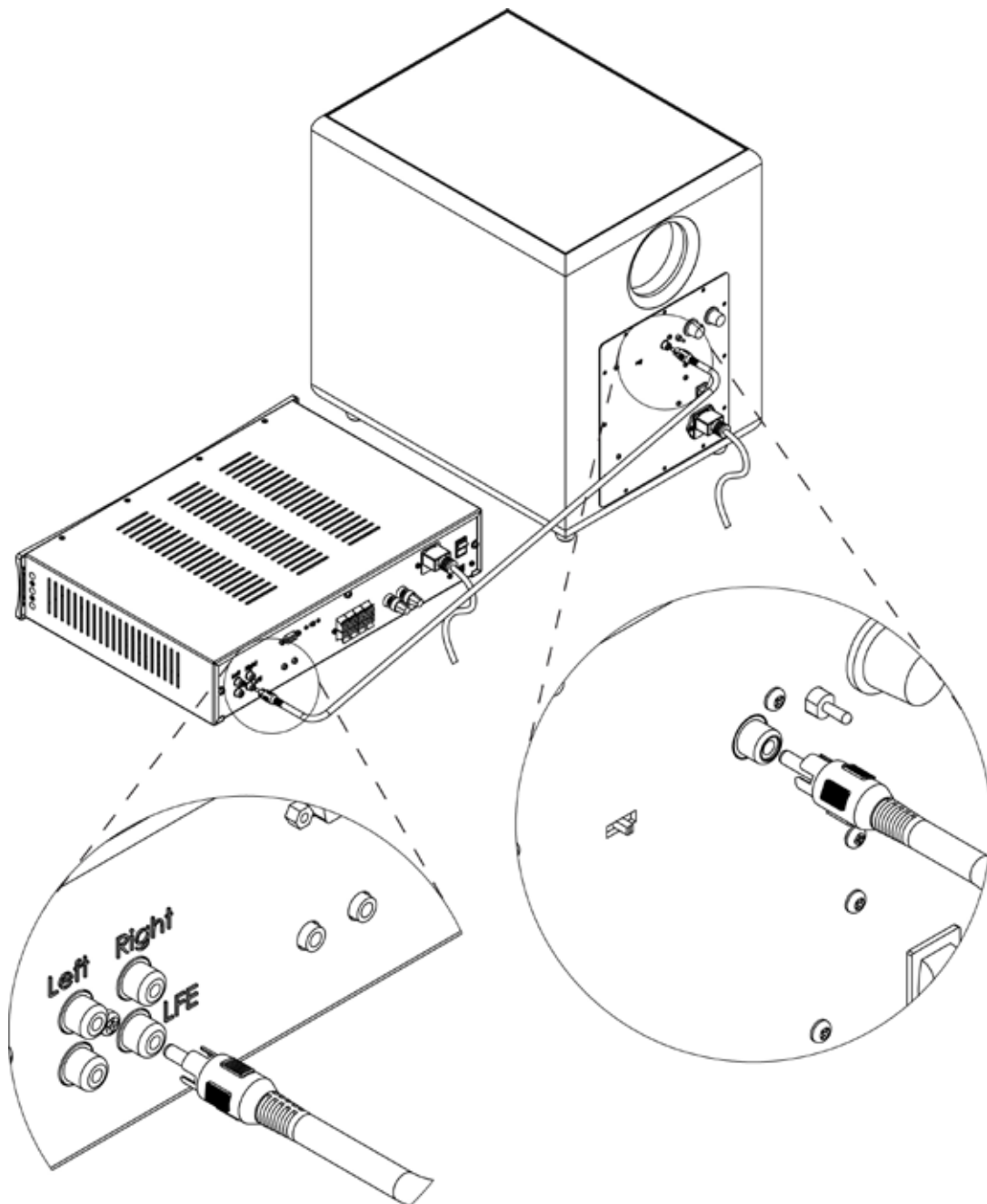

1. Use the RCA cable, supplied by you, to connect one end of the RCA cable to the subwoofer's LFE In input.
2. Connect the other end of the RCA cable to either the receiver's:
 - LFE or SUB output
 - Or the R output channel (red or purple connector)
 - Or use a "Y" connector (not included) to connect both the R and L output channels
3. Go to the **Adjust Subwoofer Controls for Listening Preferences** instructions next.

NOTE: Do not use the subwoofer's LFE connection option if you are already using the wireless connection option.

Mount Wireless Transmitter on Wall (Optional)

Optionally, you can mount the wireless transmitter on the wall or place in a location that better organizes your audio components. The transmitter doesn't have to be visually in view in the room to function properly.

1. Use the template below to mark the mounting locations on the wall. Mark the two screw locations for either the horizontal or vertical mounting orientation.
2. Hand turn one of the included self-tapping wood screws into each marked location. Tighten the screws until about 1/8" (3.17mm) of the screw shank is exposed.
3. Hook two of the slotted holes on back of the wireless transmitter to the two screws. There is no right way up for the transmitter. It can be mounted in any orientation.

NOTE: The provided wood screws aren't suitable for stone or other hard wall surfaces. If you can't hand drive the screws, you may need to drill holes and provide other wall anchors.

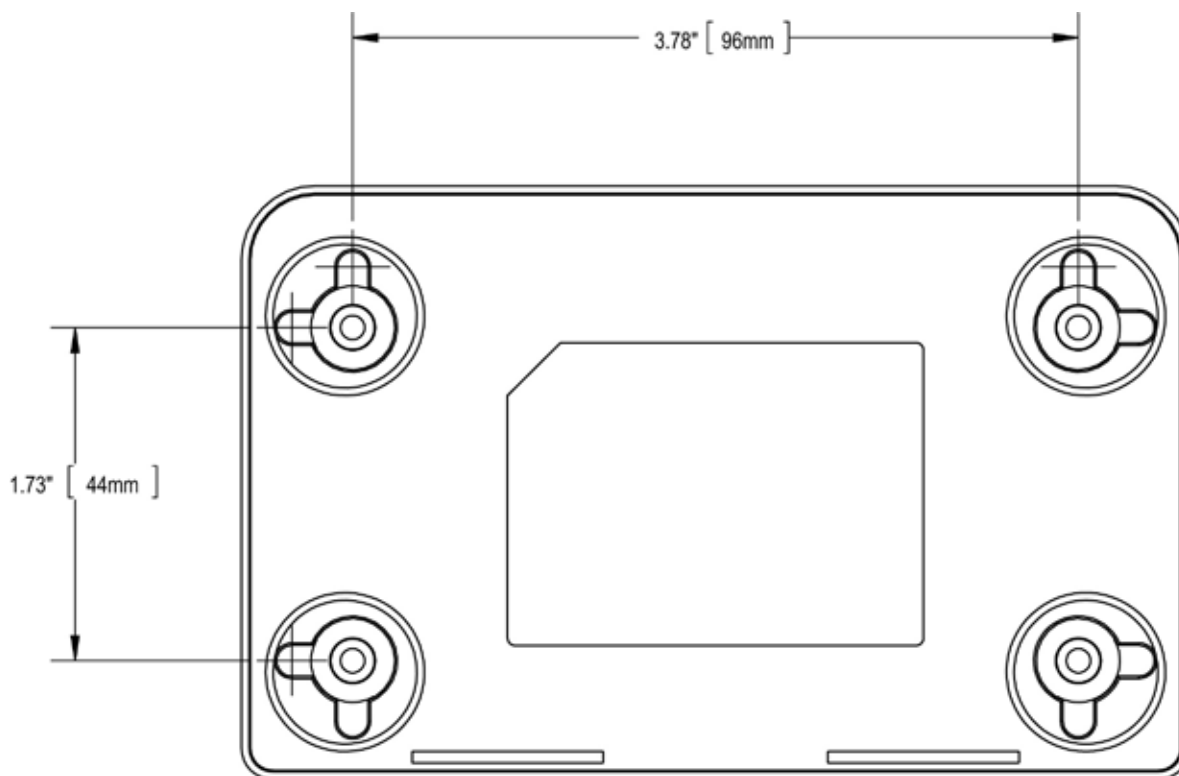

Wireless Transmitter Mounting Template

MAINTAIN

Protect Subwoofer from Damage

DO NOT PUT HEAVY OBJECTS ON TOP of the subwoofer cabinet or wireless transmitter that could scratch or dent the cabinet or case.

DO NOT ALLOW OBJECTS TO FALL INTO OR LIQUIDS TO SPILL ON THE SUBWOOFER ENCLOSURE.

DO NOT EXPOSE SUBWOOFER TO DRIPPING OR SPLASHING FROM LIQUIDS.

DO NOT PLACE LIQUID-FILLED OBJECTS ON OR NEAR THE SUBWOOFER. Examples of liquid-filled objects include flower vases, beverages and liquid-fueled lamps.

DO NOT PUSH OBJECTS OF ANY KIND into the subwoofer or transmitter openings.

DO NOT PLACE BURNING CANDLES, INCENSE, OR SMOKING PRODUCTS ON TOP OF OR NEAR THE SUBWOOFER.

DO NOT PLACE A LAPTOP COMPUTER ON TOP OF THE SUBWOOFER. Damage could occur to either the laptop hardware or the subwoofer finish.

Clean

USE A CLEAN, SOFT DAMP CLOTH to remove dust or fingerprints from the subwoofer cabinet. Unplug the subwoofer power cord from the power outlet before cleaning to prevent static electricity from damaging the subwoofer during cleaning.

DO NOT CLEAN THE SUBWOOFER CABINET OR WIRELESS TRANSMITTER CASE with detergents, soaps, abrasives, aerosol sprays, chemical solvents, alcohol, or other cleaning solutions.

Service

DO NOT ATTEMPT TO SERVICE THE SUBWOOFER OR WIRELESS TRANSMITTER YOURSELF beyond what is described in this owner's manual.

ONLY USE QUALIFIED SERVICE TECHNICIANS TO REPAIR DAMAGED PARTS. Service the subwoofer or transmitter using qualified service technicians when:

- A power cord or plug is damaged
- The power socket on the subwoofer or transmitter is damaged
- Objects have fallen into the subwoofer or liquid has spilled into the subwoofer
- The subwoofer was rained on or has become partially or fully submerged in water
- The subwoofer does not operate normally or exhibits a marked change in performance
- The cabinet has been dropped or is damaged
- The subwoofer driver's cone and/or suspension is physically damaged

Troubleshoot

IF THE SUBWOOFER'S ACTIVE LIGHT ISN'T YELLOW OR RED:

1. Verify that the subwoofer is plugged into a live power outlet.
2. Verify that the subwoofer's POWER switch is in the ON position.
3. Verify that the power cord is not damaged. If damaged, replace the cord.

IF THE SUBWOOFER ISN'T PRODUCING SOUND, BUT ITS ACTIVE LIGHT IS YELLOW OR RED:

1. Verify that the wireless transmitter is plugged into a live power outlet.
2. Verify that the wireless transmitter's inputs are connected to the receiver's output. This wire may have become accidentally disconnected.
3. Increase the subwoofer's VOLUME level.
4. Increase the receiver's LFE or SUB OUT volume level, if it is adjustable.
5. If your receiver has a switch or menu to enable its LFE or SUB OUT, make sure this switch or menu is set to ON or YES.
6. Verify that the wireless transmitter's light is on solid. If the transmitter's light isn't on solid and the same CHANNEL is selected on both the wireless transmitter and subwoofer, select another matching CHANNEL for the wireless transmitter and subwoofer.

IF THE BASS DOESN'T SOUND LOUD ENOUGH TO YOU:

1. Increase the subwoofer's VOLUME level.
 2. Increase the receiver's LFE or SUB OUT volume level, if it is adjustable.
 3. Put the subwoofer closer to a corner of your room.

IF THE SUBWOOFER OUTPUT IS DISTORTED, INTERMITTENT OR STOPS:

The subwoofer may have shut down due to the protection circuitry.

1. Reduce the volume setting; or
2. Shut the subwoofer off until normal operating conditions return.

OR

The subwoofer and transmitter may have lost their broadcast connection.

1. Turn off power to both the subwoofer and wireless transmitter.
2. Turn back on power to both the subwoofer and wireless transmitter.
3. If cycling the power doesn't re-establish the broadcast connection, select another matching CHANNEL for the wireless transmitter and subwoofer.
4. If selecting another CHANNEL doesn't re-establish the broadcast connection, decrease the distance between the subwoofer and the wireless transmitter to increase the broadcast signal strength between them.
5. Verify that the transmitter and subwoofer aren't in close proximity to other electronic devices that could interfere with the wireless transmission and reception.

Packaging

Save the carton and packing materials for future use. Using other packaging for this unit may result in severe damage when shipping or moving. You can use this packaging should you ever move or need to return the subwoofer to Velodyne for service. To save storage space, you can flatten the box and put the other packing material in a plastic bag.

RESOURCES

Specifications

Model	WiC-10
Woofers	10" downward firing (7.65" piston diameter)
Amplifier: Class D	200 Watts Dynamic, 125 Watts RMS Power
Magnet Structure	2 lbs. (0.9 Kg)
Frequency Response	33 Hz – 140 Hz (+/- 3 dB)
Voice Coil:	1.6" copper wound
Cone	Coated fiber
Speaker-level Pass-through	Full range
Low-Pass Crossover	50 Hz – 200 Hz
Phase	0° or 180 °
Auto On/Off	Yes
Video Shielding	Yes
Cabinet Design	Bass-reflex with built-in power amplifier
Cabinet (H x W x D) (includes feet)	16" x 12" x 15.5" (40 cm x 30 cm x 39.5 cm)
Shipping Weight (approximate)	35 lbs. (16 Kg)
Wireless Transmitter Range	50' (15 m)
Wireless Transmitter Frequency	2.4 GHz
Warranty (North America)	3 years electronics (parts and labor). 5 years driver (parts and labor)

Protection Circuitry

The subwoofer is equipped with protection circuitry to provide maximum performance with greatest reliability.

The subwoofer is protected against:

- Overdriving the speaker
- Overdriving the amplifier
- Overheating the amplifier
- Excessive drop in power line voltage

The overdrive protection circuitry operates constantly without being audible under most situations.

If the subwoofer should shut down, reduce the volume setting and shut the subwoofer off until it cools down. The time the subwoofer takes to cool down depends on the ambient room temperature, but typically at least 10 minutes are required for the subwoofer to cool down and recover from the thermal shutdown.

Also, plug the unit into a different wall socket. Overloaded sockets or damaged home wiring circuits can cause power voltage drops while the subwoofer is drawing high power levels. This condition can result in the subwoofer shutting down intermittently.

REGULATORY INFORMATION

FCC Compliance Statement

This device complies with part 15 of the FCC Rules. Operation is subject to the following two conditions:

1. This device may not cause harmful interference, and
2. This device must accept any interference received, including interference that may cause undesired operation.

FCC Warning

This equipment has been tested and found to comply with the limits for a Class B digital device, pursuant to Part 15 of the FCC Rules. These limits are designed to provide reasonable protection against harmful interference in a residential installation. This equipment generates, uses and can radiate radio frequency energy and, if not installed and used in accordance with the instructions, may cause harmful interference to radio communications. However, there is no guarantee that interference will not occur in a particular installation. If this equipment does cause harmful interference to radio or television reception, which can be determined by turning the equipment off and on, the user is encouraged to try to correct the interference by one or more of the following measures:

- Reorient or relocate the receiving antenna.
- Increase the separation between the equipment and the receiver.
- Connect the equipment into an outlet different from that to which the receiver is connected.
- Consult the dealer or an experienced radio/TV technician for help.

The Federal Communications Commission warns that changes or modifications of the unit not expressly approved by the party responsible for compliance could void the user's authority to operate the equipment.

EUROPEAN UNION (EU) DECLARATION OF CONFORMITY

This product complies with the requirements and other relevant provisions of the R&TTE Directive as well as CE-LVD (Safety) and CE-EMC (Emissions & Immunity).

Radio Frequency Exposure Limit Requirements

Keep a minimum separation of 8 inches (20 cm) between the transmitter and any person to comply with FCC and EU exposure limit requirements.

Listen Responsibly

REFRAIN FROM LISTENING TO MUSIC AT HIGH VOLUMES for long periods of time to protect you from permanent hearing damage. The United States Occupational Health and Safety Administration (OSHA) standards recommend not listening to sound levels of 85 dB for more than 8 hours and to wear hearing protection if sound levels exceed 85 dB. Refer to the OSHA website for more information and updated recommendations about sound levels and hearing damage: www.osha.gov/dts/osta/otm/noise/standards_more.html

LEGAL NOTICE

Subwoofer Recycling

These products should not be treated as household waste. Instead, the subwoofer and transmitter should be taken to a certified collection point so that the electrical and electronic components can be recycled. By recycling these products through a certified collection point, you prevent potential environmental damage and help to conserve natural resources used in these products. Certain international, national and/or local laws and/or regulations may also apply regarding the disposal of this subwoofer. For further information, contact your local waste disposal service, your local city government office, or the retailer where you purchased this subwoofer.

Trademarks

The Velodyne logo is a trademark of Velodyne Acoustics, Inc.

FOR YOUR RECORDS

DATE/PLACE OF PURCHASE:	PRODUCT MODEL:	PRODUCT SERIAL NUMBER:
-------------------------	----------------	------------------------

NOTE: If you need to file a warranty claim for your product, you will still need to submit to Velodyne the original sales invoice or other proof of ownership and date of purchase.

Please validate your product warranty by completing the warranty registration online within 30 days at:
velodyne.com/warranty-subwoofer

For detailed warranty information, please visit us online at:
velodyne.com/warranty-subwoofers

The warranty information indicated above refers to products purchased in the United States and Canada only. If you purchased your product outside of the United States or Canada, please consult your local authorized Velodyne dealer for warranty registration and information.

WiConnect

Wireless Subwoofer

WiConnect-RevB_MAY2012

Velodyne Acoustics, Inc.

345 Digital Drive

Morgan Hill, CA 95037

www.velodyne.com

408.465.2800 voice

408.779.9227 fax

408.779.9208 service fax

Service E-mail: service@velodyne.com

Product E-mail: help@velodyne.com

Technical E-mail: techhelp@velodyne.com

Free Manuals Download Website

<http://myh66.com>

<http://usermanuals.us>

<http://www.somanuals.com>

<http://www.4manuals.cc>

<http://www.manual-lib.com>

<http://www.404manual.com>

<http://www.luxmanual.com>

<http://aubethermostatmanual.com>

Golf course search by state

<http://golfingnear.com>

Email search by domain

<http://emailbydomain.com>

Auto manuals search

<http://auto.somanuals.com>

TV manuals search

<http://tv.somanuals.com>