

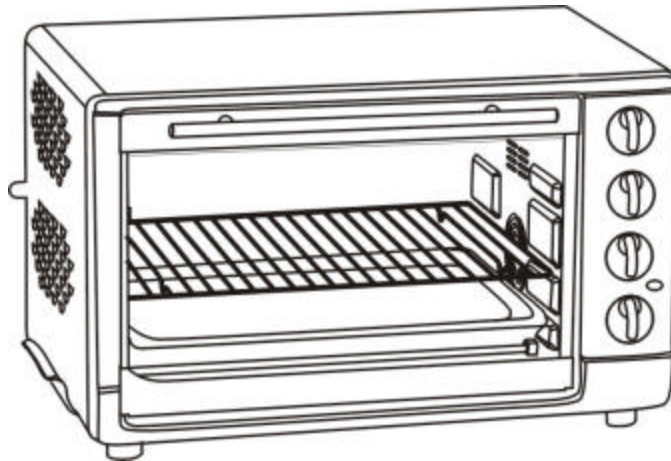

**CONVECTION OVEN / BROILER
INSTRUCTION MANUAL
HORNO DE CONVECCION / ASADOR
MANUAL DE INSTRUCCIONES**

Model Number / No. de Modelo: OCR43SS



BEFORE USE, PLEASE READ AND FOLLOW ALL SAFETY RULES AND OPERATING INSTRUCTIONS.

Avanti has a policy of continuous improvement on its products and reserves the right to change materials and specifications without notice.

La sección en español empieza en la página 17.

**Avanti Products, A Division of The Mackle Co., Inc.
P.O. Box 520604 - Miami, Florida 33152
www.avantiproducts.com**

REGISTRATION INFORMATION

Thank you for purchasing this fine Avanti product. Please fill out this card and return it within 100 days of purchase and receive these important benefits to the following address:

**Avanti Products, A Division of The Mackle Co., Inc.
P.O. Box 520604 - Miami, Florida 33152 USA**

✍ Protect your product:

We will keep the model number and date of purchase of your new Avanti product on file to help you refer to this information in the event of an insurance claim such as fire or theft.

✍ Promote better products:

We value your input. Your responses will help us develop products designed to best meet your future needs.

------(detach here)-----

Avanti Registration Card

Name			Model #	Serial #
Address			Date Purchased	Store/Dealer Name
City	State	Zip	Occupation	
Area Code	Phone Number		As Your Primary Residence, Do You: <input type="checkbox"/> Own <input type="checkbox"/> Rent	
Did You Purchase An Additional Warranty: <input type="checkbox"/> Extended <input type="checkbox"/> None			Your Age: <input type="checkbox"/> under 18 <input type="checkbox"/> 18-25 <input type="checkbox"/> 26-30 <input type="checkbox"/> 31-35 <input type="checkbox"/> 36-50 <input type="checkbox"/> over 50	
Reason For Choosing This Avanti Product: Please indicate the most important factors that influenced your decision to purchase this product.			Marital Status: <input type="checkbox"/> Married <input type="checkbox"/> Single	
<input type="checkbox"/> Price			Is This Product Used In The: <input type="checkbox"/> Home <input type="checkbox"/> Business	
<input type="checkbox"/> Product Features			How Did You Learn About This Product: <input type="checkbox"/> Advertising	
<input type="checkbox"/> Avanti Reputation			<input type="checkbox"/> In Store Demo <input type="checkbox"/> Personal Demo	
<input type="checkbox"/> Product Quality			<input type="checkbox"/> Other _____	
<input type="checkbox"/> Salesperson Recommendation			Comments _____	
<input type="checkbox"/> Friend/Relative Recommendation			_____	
<input type="checkbox"/> Warranty			_____	
<input type="checkbox"/> Other _____			_____	

HELP US HELP YOU ...

Read this guide carefully.

It is intended to help you operate and maintain your new appliance properly.

Keep it handy to answer your questions. If you don't understand something or you need more assistance, please call:

**Avanti Customer Service
800-220-5570**

Keep proof of original purchase date (such as your sales slip) with this guide to establish the warranty period.

Write down the model and serial numbers.

You'll find them on a label located on the back side of the unit.

Please write these numbers here:

Date of Purchase

Model Number

Serial Number

Use these numbers in any correspondence or service calls concerning your appliance.

If you received a damaged appliance, immediately contact the dealer (or builder) that sold you the appliance.

Save time and money. Before you call for service, check the Problem Solver Guide. It lists causes of minor operating problems that you can correct yourself.

IF YOU NEED SERVICE

We're proud of our service and want you to be pleased. If for some reason you are not happy with the service you receive, here are some steps to follow for further assistance.

FIRST, contact the people who serviced your appliance. Explain why you are not pleased. In most cases, this will solve the problem.

NEXT, if you are still not pleased, write all the details, including your telephone number, and send it to:

**Customer Service
Avanti Products
10880 NW 30 Street
Miami, FL 33172 USA**

PARTS AND FEATURES

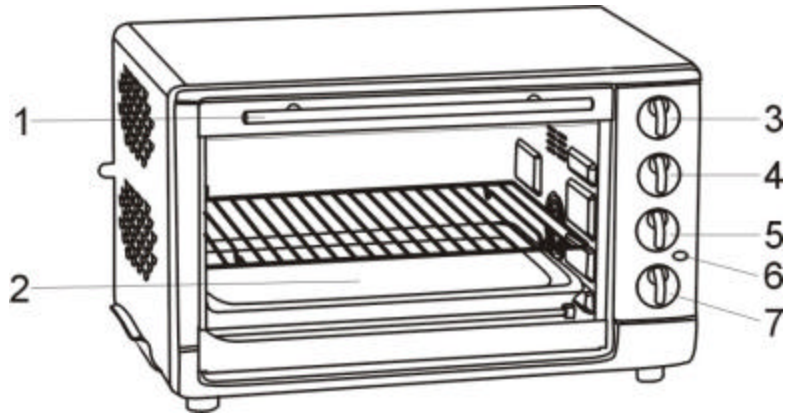

- 1. HANDLE
- 2. FULL VIEW GLASS DOOR
- 3. TEMPERATURE CONTROL KNOB
- 4. FUNCTION CONTROL KNOB
- 5. CONVECTION-ROTISSERIE CONTROL KNOB
- 6. POWER INDICATOR LIGHT
- 7. TIMER CONTROL KNOB

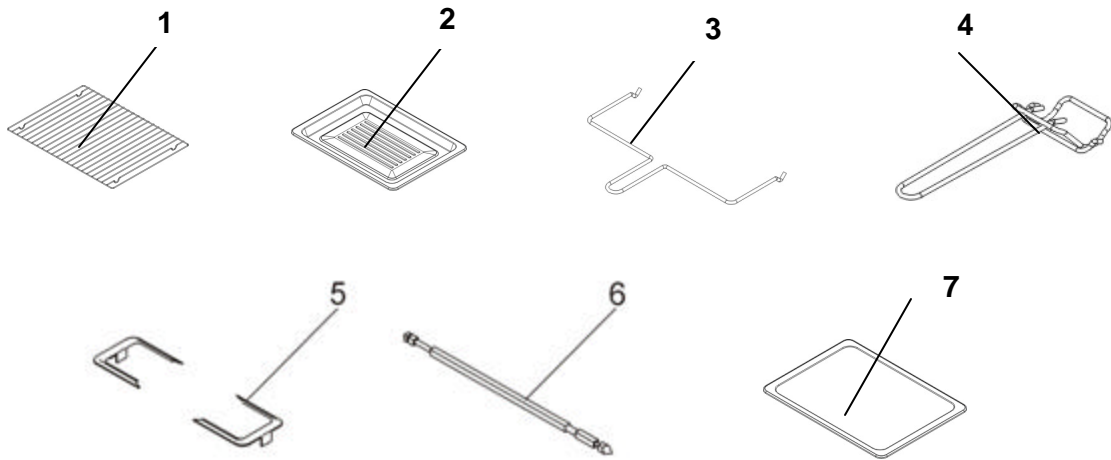

ACCESSORIES

- 1. OVEN WIRE RACK
- 2. BAKE/BROIL/DRIP PAN
- 3. ROTISSERIE SKEWER HANDLING TOOL
- 4. BAKE/BROIL/DRIP HANDLING TOOL
- 5. ROTISSERIE MEAT FORKS
- 6. ROTISSERIE SKEWER
- 7. CRUMB TRAY

TABLE OF CONTENTS

Registration Information	3
Help Us Help You	5
Parts and Features	6
Important Safety Instructions	8
Installation Instructions	9
Before Using Your Appliance	9
Installation of Your Appliance	9
Electrical Connection	10
Operating Your Appliance	11
Control Panel	11
Using Your Oven	12
Care and Maintenance	14
Cleaning Your Appliance	14
Storing Your Appliance	14
Troubleshooting Guide	14
Service For Your Appliance	15
Your Avanti Warranty	15
Wiring Diagram	16
Instrucciones en Español	17 - 20

IMPORTANT SAFETY INSTRUCTIONS



To reduce the risk of fire, electrical shock, or injury when using your appliance, follow these basic precautions:

When using electrical appliances, basic safety precautions should always be followed including the following:

READ ALL INSTRUCTIONS, PRODUCT LABELS AND WARNINGS BEFORE USING THE APPLIANCE.

- ? Do not touch hot surfaces, use handles or knobs. Always use oven mitts when handling hot materials and allow metal parts to cool before cleaning. Allow the unit to cool thoroughly before putting in or taking off parts.
- ? When the unit is not in use and before cleaning, unplug the appliance from the wall outlet. Make sure the appliance is turned off before unplugging.
- ? To protect against risk of electrical shock, do not immerse the appliance in water or any other liquids.
- ? While using your appliance, you must take into consideration not to touch the surfaces as the entire cabinet, as well as the front glass door get very hot.
- ? Don't leave children alone or unattended where the appliance is hot or in operation. This appliance is not designed to be used by children.
- ? We do not recommend the use of extension cords to operate this unit.
- ? Never use your appliance for heating the room. Your oven is not designed to heat your kitchen.
- ? Do not operate this or any appliance with a frayed or damaged cord or plug, after the appliance malfunctions, is dropped or has been damaged in any manner.
- ? Do not use attachments not recommended by the manufacturer; they may cause fire, electric shock or personal injury.
- ? Do not use outdoors or for commercial purposes.
- ? Do not use this appliance for other than its intended use.
- ? Do not let the cord dangle over the edge of a tabletop, countertop or to touch hot surfaces.
- ? Do not place the appliance near a hot gas, electric burner or in a heated oven.
- ? Extreme caution should be used when using containers constructed of other than metal or glass.
- ? A fire may occur if the appliance is covered or touching flammable materials, including curtains, draperies, walls, etc., when in operation. Do not store any items on top of the appliance when in operation.
- ? Do not store any materials, other than manufacturer's recommended accessories, in this unit when not in use.
- ? Do not place any flammable materials in the appliance, such as paper, cardboard, plastic or any materials that may catch fire or melt.
- ? Never clean the appliance with flammable liquids. The fumes can create a fire hazard or explosion.
- ? Do not cover the appliance with metal foil. This will cause overheating of the appliance.
- ? Oversized foods or metal utensils must not be inserted in the appliance as they may create a fire or risk of electrical shock.
- ? Do not clean with metal scouring pads. Pieces can break off the pad and touch electrical parts involving a risk of electrical shock.
- ? When broiling, use extreme caution when removing tray or disposing of hot grease.
- ? To turn this appliance off, return all controls to the "0"/**OFF** position, then remove plug from wall outlet.
- ? Cooked food can be very hot, especially pastry filling. Handle with care.
- ? Never pick up a flaming pan. Turns the controls to the "0"/**OFF** position. Unplug the unit from the AC wall outlet. Smother a flaming pan on a surface unit by covering the pan completely with a well fitting lid.
- ? Do not use water on grease fires. Flaming grease outside a pan can be put out by covering it with baking soda, multipurpose dry chemical, or fire extinguisher. Flame in the oven can be smothered completely by closing the oven door and turning the oven off and unplugging the unit from the A/C outlet or by using baking soda, multipurpose dry chemical, or fire extinguisher.

This Unit Is For Household Use Only

- SAVE THESE INSTRUCTIONS -

INSTALLATION INSTRUCTIONS

Before Using Your Appliance

- ? Remove the exterior and interior packing.
- ? Check to be sure you have all of the following parts:
 - ? 1 Bake/Broil/Drip Pan
 - ? 1 Bake/Broil/Drip Handling Tool
 - ? 1 Oven Wire Rack
 - ? 1 Rotisserie Skewer Handling Tool
 - ? 2 Rotisserie Forks with Screws
 - ? 1 Rotisserie Skewer
 - ? 1 Instruction Manual
- ? Remove all the items inside your oven and clean the interior surface with lukewarm water using a soft cloth.
- ? Do not attempt to repair or replace any part of your oven unless it is specially recommended in this manual.
- ? This appliance requires 1400W and should be the only appliance operating on the same circuit.

NOTICE

Before you use this oven for the first time: The heating elements have a protective coating, which must be burned off before use. To do this, open the oven door and set the temperature control knob to 250°C/480°F. Move the function selector to toast and rotate the timer control knob to approximately 15 minutes. It is important to ensure adequate ventilation during this period.

Installation of Your Appliance

- Select a location for the appliance. The location should be in an open area on a flat counter where the plug will reach an outlet.
- ? When positioning the appliance, it should be set on a flat, steady surface.
 - ? Do not block air vents. If they are blocked during operation, the oven may overheat and eventually cause the appliance failure.
 - ? Keep the appliance away from hot air, steam or splashing liquids when choosing a place to locate it, otherwise, the unit's operation may be adversely affected, causing it to break down.
 - ? Direct sunlight may affect the acrylic coating and heat sources may increase electrical consumption.
 - ? Plug the appliance into an exclusive properly installed grounded wall outlet. Any questions concerning power should be directed toward a certified electrician or an authorized Avanti Products service center.
 - ? Do not place anything on the top of the broiler oven and automatic toaster.
 - ? Keep the appliance at least 5 inches away from rear wall to ensure the proper ventilation.

Electrical Connection

Warning

Improper use of the grounded plug can result in the risk of electrical shock. If the power cord is damaged, have it replaced by an authorized Avanti Products service center.

The appliance is supplied with a molded 3-prong grounding type plug and should be used in combination with a properly connected grounding –type outlet. If a grounding type outlet is not available, an adapter may be obtained so that a 2-slot wall outlet can be used with a 3-prong plug. The adapter must be grounded by attaching its grounding plug under the screw of the outlet cover plate.

A short power cord is provided to reduce the hazards resulting from entanglement or tripping over a longer cord.

An extension cord may be used with care, however, be sure the marked electrical rating is at least as great as the rating of this appliance. The extension cord should be positioned such that it does not drape over the counter or tabletop where it can be pulled on by children or tripped over. The electrical rating of this appliance is listed on the rear wall of the appliance.

Do not under any circumstances cut or remove the third ground prong from the power cord supplied.

This unit requires a standard 115/120 Volts A.C. ~/60Hz electrical grounded outlet with three-prong.

The cord should be secured behind the mini kitchen and not left exposed or dangling to prevent accidental injury.

Do not pinch, knot, or bend the power cord in any manner.

To protect against electrical shock, do not immerse cord, plug, or appliance itself in water or other liquid.

Never unplug the appliance by pulling the power cord. Always grip the plug firmly and pull straight out from the receptacle.

OPERATING YOUR APPLIANCE

Control Panel

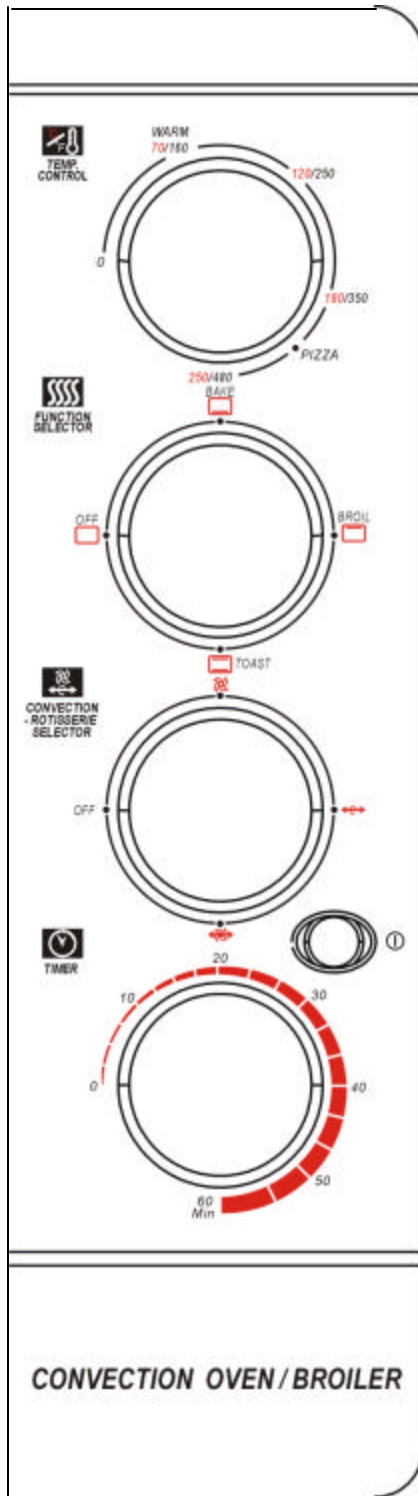

TEMPERATURE CONTROL KNOB

Turn the knob clockwise to select the desired temperature up to 250 °C/480 °F. To switch off the heating elements of oven turn the temperature control to the “0” setting position.



FUNCTION SELECTOR KNOB

There are three functions – BAKE, BROIL and TOAST.

To switch off the heating elements of oven turn the function selector to the **OFF** setting position.

CONVECTION-ROTISSERIE SELECTOR KNOB

You can control the convection fan and rotisserie operations by turning the knob to the desired following positions.

-  - Fan will operate
-  - Rotisserie will operate
-  - Fan and rotisserie will operate

If you do not need the additional functions, keep the knob in the **OFF** position

TIMER SELECTOR KNOB

You can set cooking time up to 60 minutes. It will automatically turn the oven off at the end of the cooking time selected with the sound of a bell signal.

To switch off the oven turn the timer selector to the “0” setting position.

OPERATING INDICATING LIGHT

The indicator light will come **ON** when the oven is in use.

Using Your Oven

Be sure that all the selector knobs are turned "0"/ **OFF** position before plugging the cord into the outlet for use and when unplugging the appliance after use.

You will be able to turn the timer knob to the desired time (max 60 minutes). At the end of the cooking time a bell signal sounds and the oven will turn off automatically.

Please note that none of the OVEN selections (BAKE, FAN BAKE, BROIL, FAN BROIL, ROTISSERIE, CONVECTION, OR TOAST) will operate without the TIMER knob turned to desired cooking time.

Preheating the Oven

Turn the TEMPERATURE control knob to the desired temperature.

Turn the FUNCTION selector knob to the desired function.

Turn the timer selector knob to the "15~20" minute marking for the oven to preheat.

To Use the DEFROST Function

Arrange food in the drip/baking pan.

Keep the function selector knob to the **OFF** position.

Turn the CONVECTION - ROTISSERIE selector knob to the  position.

Turn the TIMER selector knob to your desired cooking time.

The motor fan will operate to defrost.

When DEFROST is completed, turn all knobs to the "0"/ **OFF** position, open door fully and remove food carefully.

When defrosting do not preheat oven. Allow 15-20 minutes per side for meats or fish to defrost. Always cook food promptly after thawing.

To Use the BAKE or FAN BAKE Function

Arrange food on the wire rack or in the drip/baking pan.

Turn the FUNCTION selector knob to the BAKE position.

Turn the CONVECTION - ROTISSERIE selector knob to the  position for FAN BAKE, otherwise keep it in the **OFF** position.

Turn the TIMER selector knob to your desired cooking time.

Turn the TEMPERATURE control knob to the desired temperature.

The bottom heater element will cycle **ON** and **OFF** to maintain the selected temperature. At the same time the motor fan will operate for FAN BAKE.

When BAKING is completed, turn all knobs to the "0"/ **OFF** position, open door fully and remove food carefully, using the metal handling tool provided.

To Use the BROIL or FAN BROIL Function

Arrange food on the wire rack or in the drip/baking pan. Close the door to the first notch, leaving approximately a 3-inch gap at the top. This will ensure adequate airflow during broiling.

Turn the FUNCTION selector knob to the BROIL position.

Turn the CONVECTION - ROTISSERIE selector knob to the  position for FAN BROIL, otherwise keep it in the **OFF** position.

Turn the TIMER selector knob to your desired cooking time.

Turn the TEMPERATURE control knob to the desired temperature.

Only the top heater element will cycle **ON** and **OFF** to maintain the desired temperature in the oven. At the same time the motor fan will operate for FAN BROIL. For best results the oven should be preheated 20 minutes before adding the food to be broiled.

Turn food over about halfway through the broiling time.

When BROILING is completed, turn all knobs to the "0"/ **OFF** position, open door fully and remove food carefully, using the metal handling tool provided.

To Use the ROTISSERIE Function

Place the drip/baking pan at the bottom position.

Arrange food as following steps:

- ? Place one meat fork on the end of the rotisserie skewer opposite the point, with the tines facing the center and tighten the screw slightly.
- ? Slide the pointed end of the rotisserie directly through the center of the meat.
- ? Place the other meat fork on the other end of the rotisserie. Make sure the forks secure the roast or chicken on the skewer and tighten the screws.
- ? Make sure the forks are not too close to the interior wall of the oven and interfere with the movement of the meat.
- ? When cooking poultry, legs and wings should be secured to the body with string making the chicken as compact as possible. This is necessary for smooth movement of the rotisserie and prevents dragging.
- ? Season or baste the meat as desired.
- ? Place the drip/baking pan directly on the bottom of the oven.
- ? Insert the pointed end of the skewer in the drive socket on the right interior wall of the oven and put the other end of the skewer in the bracket on the left interior wall of the oven.

Turn the FUNCTION selector knob to the BROIL position.

Turn the CONVECTION - ROTISSERIE selector knob to the  position.

Turn the TIMER selector knob to your desired cooking time.

Turn the TEMPERATURE control knob to the desired temperature.

The top heater element will cycle **ON** and **OFF** to maintain the selected temperature. At the same time the motor fan will operate. Rotisserie roasting is a healthy way to cook meats because the slow turning skewer provides natural basting of meats while fats drip away. The rotisserie can be used to roast meats up to 4 pounds and will easily handle a 4-pound chicken. Season your roast or chicken with your favorite seasoning as desired. It is not necessary to preheat the oven for rotisserie roasting.

When ROTISSERIE is completed, turn all knobs to the "0"/ **OFF** position.

Remove the rotisserie food from the oven by using the Metal Skewer Handling Tool to remove the skewer from the hole by lifting the left end of the skewer and sliding it to the left. And remove the drip/bake pan from the oven by using the metal handling tool provided.

Using a potholder, loosen the screws on the meat forks and remove the rotisserie skewer from the meat. Carefully remove the meat forks and carve the meat.

CAUTION: *The rotisserie skewer, meat forks and screws will be hot.*

To Use the CONVECTION Function

Arrange food on the wire rack or in the drip/baking pan.

Turn the FUNCTION selector knob to the TOAST position.

Turn the CONVECTION - ROTISSERIE selector knob to the  position.

Turn the TIMER selector knob to your desired cooking time.

Turn the TEMPERATURE control knob to the desired temperature.

The top and bottom heater elements will cycle **ON** and **OFF** to maintain the selected temperature. At the same time the motor fan will operate. Convection will keep a consistent temperature. The oven heats quickly, so preheating is not necessary or desirable. The fan circulates the hot air around the food making baked food rise quickly and evenly.

When CONVECTION is completed, turn all knobs to the "0"/ **OFF** position, open door fully and remove food carefully, using the metal handling tool provided.

To Use the TOAST Function

Turn the FUNCTION selector knob to the TOAST position.

Keep the CONVECTION – ROTISSERIE selector knob in the **OFF** position.

Turn the TIMER selector knob to your desired cooking time.

Turn the TEMPERATURE control knob to the desired temperature.

Place the oven rack in the upper position.

No preheat period is required before toasting.

Place the bread to be toasted directly on the rack in the center of the oven, close the door.

Both the top and bottom elements will operate when TOAST function is used.

When TOASTING is completed, turn all knobs to the "0"/ **OFF** position, open door fully and remove food carefully, using the metal handling tool provided.
 Different types of bread require different toasting times. Lighter breads and waffles require a shorter toasting time. Darker breads, muffins, and English muffins require a longer toasting time.

CARE AND MAINTENANCE

Cleaning Your Appliance

- ? Before cleaning your appliance, unplug it and allow it to cool.
- ? Remove the rotisserie skewer, wire rack, drip/baking pan and crumb tray.
- ? Use a damp cloth to wash the inside with warm water and a mild detergent. Do not Immerse in Water. Abrasive cleaners, scrubbing brushes and chemical cleaners may damage the coating on this unit.
- ? Wash the rotisserie skewer, wire rack, drip/baking pan and crumb tray with a mild detergent solution.
- ? The glass oven door should be cleaned regularly with a non-abrasive liquid cleaner.
- ? Rinse with a damp cloth and then a dry one.
- ? The outside of the appliance should be cleaned with mild detergent and warm water.
- ? Occasionally wiping the surface of the burners with a trace of clean cooking oil will help to maintain their appearance.

Storing Your Appliance

Allow the appliance to cool completely before storing. If storing the appliance for long periods of time make certain that the appliance is clean and free of food particles. Store the appliance in a dry location such as on a table or countertop or in a cupboard shelf. Other than the recommended cleaning, no further user maintenance should be necessary.

PROBLEMS WITH YOUR APPLIANCE?

You can solve many common appliance problems easily, saving you the cost of a possible service call. Try the suggestions below to see if you can solve the problem before calling the servicer.

TROUBLESHOOTING GUIDE

PROBLEMS	POSSIBLE CAUSES/SOLUTIONS
? Appliance does not operate.	? Unit not plugged in. Plug the unit into a 120V AC/ 60 Hz electrical outlet. ? The circuit breaker tripped or a blown fuse. ? Be sure that the function, temperature, convection - rotisserie and timer selectors are set.
? Only one heating element is heating up.	? Function setting selection determines which heating element will operate. ? When toasting and convection, make sure the oven is not set to BROIL and other settings.
? Heating elements are not heating up.	? Heating elements will cycle ON and OFF to maintain proper heat. Make sure function selector is positioned to desired cooking setting.
? Overcooked/undercooked Foods	? Incorrect temperature setting. You may have to adjust the temperature to desired position. ? Rack placement. Rack may need to be adjusted to accommodate different foods.
? Burnt Smell	? If this occurs the first time you are using the unit, this is the initial burn in procedure (see Installation Instructions). ? Food build-up inside appliance, on heating elements or in drip/baking pan. Refer to "Cleaning Your Appliance"

SERVICE FOR YOUR APPLIANCE

We are proud of our customer service organization and the network of professional service technicians that provide service on your Avanti appliances. With the purchase of your Avanti appliance, you can be confident that if you ever need additional information or assistance, the Avanti Products Customer Service team will be here for you. Just call us toll-free.

AVANTI PRODUCTS CUSTOMER SERVICES

Product Information 800-323-5029	Whatever your questions are about our products, help is available.
Part Orders 800-220-5570	You may order parts and accessories that will be delivered directly to your home by personal check, money order, Master Card, or Visa.
In-Home Repair Service 800-220-5570	An Avanti Products authorized service center will provide expert repair service, scheduled at a time that is convenient for you. Our trained servicers know your appliance inside and out.

YOUR AVANTI WARRANTY

LENGTH OF WARRANTY	WE WILL PAY FOR
FULL ONE YEAR WARRANTY FROM DATE OF PURCHASE ON ALL PARTS EXCEPT GLASS PARTS, AND/OR PARTS DAMAGED AS A RESULT OF MISUSE OR LACK OF REASONABLE CARE.	REPLACEMENT PARTS AND REPAIR LABOR TO CORRECT DEFECTS IN MATERIALS OR WORKMANSHIP. SERVICE MUST BE PROVIDED BY AN AUTHORIZED SERVICE COMPANY.
FULL 30-DAY WARRANTY FROM DATE OF PURCHASE ON GLASS PARTS AND FINISH OF PORCELAIN ENAMEL, PAINTED OR BRIGHT METAL FINISHED PARTS	REPLACEMENT PARTS AND REPAIR LABOR TO CORRECT DEFECTS IN MATERIAL OR WORKMANSHIP. SERVICE MUST BE PROVIDED BY AN AUTHORIZED SERVICE COMPANY.

CARRY IN SERVICE ONLY.

CUSTOMER WILL BE RESPONSIBLE FOR ALL TRANSPORTATION CHARGES TO AND FROM THE AUTHORIZED SERVICE COMPANY, ALSO MAKE SURE TO SEND A COPY OF PROOF OF PURCHASE WHEN SENDING THE UNIT FOR SERVICE REPAIRS.

AVANTI PRODUCTS SHALL NOT BE LIABLE FOR INCIDENTAL OR CONSEQUENTIAL DAMAGES.

Some states do not allow the exclusion or limitation of incidental or consequential damages, so this exclusion or limitation may not apply to you. This warranty gives you specific legal rights, and you may also have other rights that vary from state to state.

This warranty is not valid outside the Continental United States.

WIRING DIAGRAM

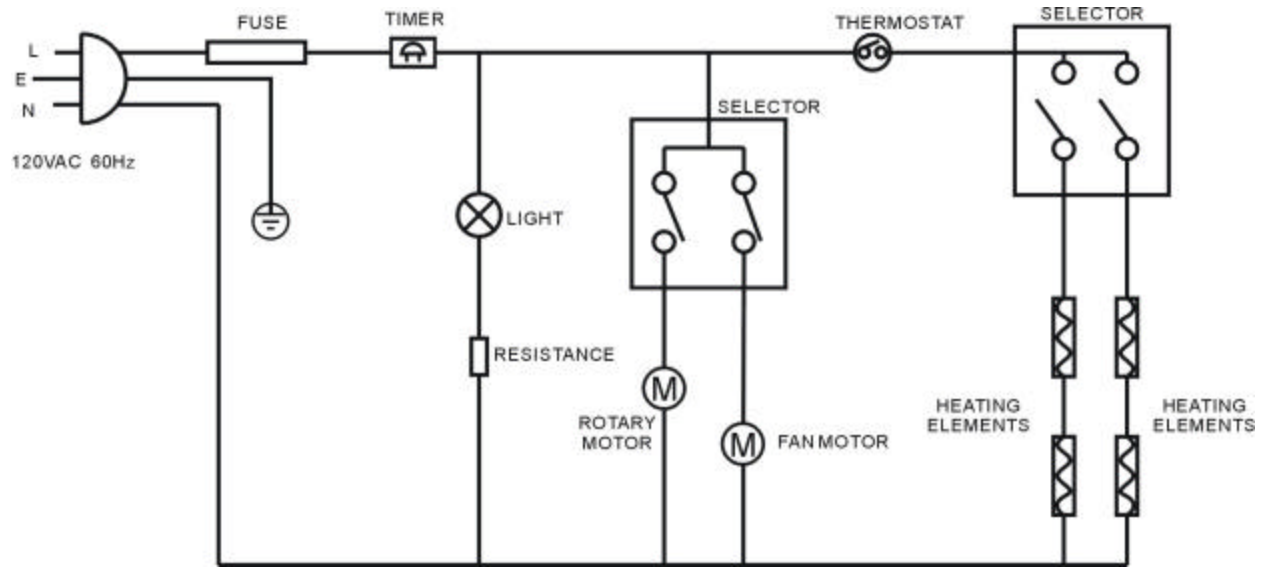

INSTRUCCIONES EN ESPAÑOL

PRECAUCIONES IMPORTANTES	PARA REDUCIR EL RIESGO DE INCENDIO, DESCARGA ELECTRICA, O DAÑO CUANDO ESTE USANDO SU HORNO SIGA ESTAS INDICACIONES.
<p>CUANDO USE APARATOS ELECTRICOS, SIEMPRE DEBEN TOMARSE ALGUNAS PRECAUCIONES BASICAS DE SEGURIDAD, INCLUYENDO LAS SIGUIENTES:</p> <ul style="list-style-type: none">? Lea todas las instrucciones, las etiquetas en el producto y las advertencias antes de usar el horno tostador.? No se recomienda el uso de cables o extensiones de corriente para el uso de esta unidad.? No toque las superficies calientes. Siempre use guantes cuando maneje materiales calientes y permita que las partes metálicas se enfríen antes de limpiarlas. Permita que la unidad se enfríe completamente antes de poner o quitar partes.? Desconecte el horno tostador de la toma de corriente cuando la unidad no esté en uso y antes de limpiarla. Nota: Verifique que el horno tostador esté apagado antes de desconectarlo.? Para protegerse contra una descarga eléctrica, no sumerja el aparato en agua o en otros líquidos.? Supervisión continua es necesaria cuando este o cualquier otro aparato sea usado cerca de niños. Este aparato no debe ser usado por niños.? No opere este ni ningún otro aparato con un cordón dañado o quemado o después de que el aparato ha funcionado inadecuadamente o ha sido dañado en cualquier forma.? No utilice accesorios o aditamentos no recomendados por el fabricante, ya que pueden causar incendios, descargas eléctricas o lesiones personales.? No se use en exteriores o con propósitos comerciales.? No use este aparato más que para lo que ha sido diseñado.? No permita que el cordón cuelgue sobre la orilla de la mesa o del mostrador o toque superficies calientes.? No lo coloque sobre o cerca de quemadores de estufas de gas o eléctricas, tampoco cerca de un horno caliente.? Tenga extremo cuidado cuando use contenedores de vidrio o metal.? Puede ocurrir un incendio si el horno tostador está en operación y en contacto o cubierto con materiales inflamables, incluyendo cortinas, tapicería, paredes, etc. No coloque ningún objeto sobre el aparato cuando esté en operación.? Cuando esta unidad no esté en operación, no almacene ningún material que no sea un accesorio recomendado por el fabricante.? No coloque dentro del horno ningún material inflamable como papel, cartón, plástico o cualquier material que se pueda incendiar o derretir.? No cubra la bandeja para migajas o ninguna parte del horno con papel aluminio o metálico. Esto puede causar el sobrecalentamiento del aparato.? Los alimentos grandes o utensilios metálicos no deben ser introducidos en el horno tostador ya que pueden causar incendios o descargas eléctricas.? No limpie la unidad con esponjas o fibras metálicas. Se pueden desprender piezas de la esponja o fibra y tocar partes eléctricas creando el riesgo de descargas eléctricas.? Cuando prepare alimentos, tenga cuidado extremo al remover la bandeja o al desechar la grasa caliente.? Para apagar este aparato, coloque todos los controles en la posición "0"/"OFF". <p style="text-align: center;">-Esta Unidad Es Sólo Para Uso Doméstico-</p> <p>Para reducir el riesgos de descarga eléctrica, este equipo posee una instalación polarizada, lo cual requiere que la persona que instale esta unidad la conecte apropiadamente a tierra sin invertir la posición de los cables.</p>	

PREPARANDO SU HORNO TOSTADOR

Si usted está usando su horno tostador por primera vez, por favor asegúrese de:

Quitar todas las etiquetas de la superficie de su tostador.

Abra la puerta del tostador y saque los documentos impresos y papeles del interior del horno tostador.

Limpie la rejilla, charola y bandeja con agua caliente y una pequeña cantidad de detergente líquido para lavar platos, utilice una esponja suave y no abrasiva. No sumerja el horno tostador en el agua.

Seque completamente la unidad antes de utilizarla.

Seleccione un lugar para colocar el horno tostador. El lugar debe ser una área abierta sobre un mostrador con superficie plana donde el enchufe tenga alcance a una toma de corriente.

Enchufe el cable en un tomacorriente de 120 voltios / 60Hz.

AVISO

ANTES DE USAR LA UNIDAD POR PRIMERA VEZ. LOS ELEMENTOS CALENTADORES TIENEN UNA CAPA PROTECTIVA QUE NECESITA SER QUEMADA ANTES DE USAR EL HORNO.

PARA REMOVER LA CAPA PROTECTIVA:

ABRA LA PUERTA.

GIRE LA PERILLA DE CONTROL DE TEMPERATURA A 250°C/480°F.

GIRE LA PERILLA DE CONTROL DE TIEMPO A 15 MINUTOS.

USTED SENTIRA UN OLOR A QUEMADO, ESTO ES NORMAL.

ASEGURESE TENER VENTILACION ADECUADA MIENTRAS HAGA ESTE PROCESO.

CALENTAMIENTO PREVIO DEL HORNO

Coloque la parrilla en la posición deseada antes de calentar el horno tostador.

Gire la perilla de control de temperatura y colóquela en la temperatura deseada.

Gire la perilla selectora en la función deseada.

PARA USAR LA FUNCION DE CALENTAMIENTO

Nota: La función de calentamiento es para calentar o mantener los alimentos calientes después de cocinarlos.

Seleccione la posición deseada de la parrilla.

Gire la perilla de control de temperatura y colóquela en la temperatura deseada.

Gire la perilla selectora de función en la posición de calentamiento o "WARM", gire el reloj al tiempo deseado. Los elementos calentadores se encenderán y apagarán alternadamente para mantener la temperatura.

Coloque los alimentos sobre la rejilla metálica o dentro de la charola para hornear.

Cuando se haya completado el calentamiento, abra la puerta completamente y saque los alimentos cuidadosamente.

PARA USAR LA FUNCION DE ASADO

Seleccione la posición deseada de la parrilla. Coloque los alimentos y cierre la puerta.

Gire la perilla de control de temperatura y colóquela en el nivel de temperatura más alto.

Gire la perilla selectora de función en la posición de asar o "BROIL" de la parte superior estará en funcionamiento.

Coloque la parrilla para asar, encima de la bandeja para hornear. Luego coloque los alimentos. Sobre la parrilla para asar, y gire la perilla de reloj al tiempo deseado. Solamente el elemento calentador de la parte superior estará en funcionamiento.

Es recomendable siempre voltear los alimentos a la mitad del ciclo de cocción.

Cuando se haya completado la cocción, abra la puerta completamente y saque los alimentos cuidadosamente, y regrese las perillas de control de temperatura, función y reloj hacia la posición de "0" y "OFF".

PARA USAR LA FUNCION DE HORNEADO

Seleccione la posición deseada de la parrilla (consulte la sección de colocación de la parrilla).

Gire la perilla de control de temperatura al nivel deseado.

Gire la perilla selectora de función en la posición de hornear o "BAKE".

Coloque los alimentos en la parrilla metálica o dentro de la bandeja para hornear, gire la perilla de reloj al tiempo deseado. Ambos elementos calentadores, el superior y el inferior estarán en funcionamiento.

Cuando se haya completado el horneado, abra la puerta completamente y saque los alimentos cuidadosamente.

Cuando esté descongelando alimentos, no caliente el horno previamente. Gire el control de temperatura y colóquelo en 250°F (120°C).

Permita que cada lado de las carnes o pescados se descongele dentro de 15 a 20 minutos. Siempre cocine los alimentos inmediatamente después de descongelar.

PARA USAR LA FUNCION DE TOSTAR

NOTA – No es necesario un período de calentamiento previo antes de tostar.

NOTA - Diferentes tipos de panes requieren de diferentes niveles de tostado. Los panes y waffles requieren tostado más ligero. Los panes más oscuros, panqués y muffins o panecillos ingleses requieren un tostado más oscuro.

Seleccione la posición deseada de la parrilla.

Gire la perilla de control de temperatura al nivel de temperatura deseado.

Gire la perilla selectora de función en la posición de tostar o "TOAST", gire la perilla de reloj al tiempo deseado.

Coloque los alimentos en la parrilla metálica.

Cuando se haya completado el tostado, abra la puerta completamente y saque los alimentos cuidadosamente.

NOTA – Los elementos calentadores superiores se encenderán y apagarán alternadamente para mantener la temperatura.

LIMPIEZA DE SU HORNO TOSTADOR

Antes de limpiar su Horno Tostador, desconéctelo del tomacorriente y permita que se enfríe. Limpie con un paño suave y húmedo. No lo sumerja en agua! Asegúrese de usar solamente jabón suave y agua.

Los limpiadores abrasivos, cepillos y limpiadores químicos pueden dañar el acabado de esta unidad.

Vacíe la bandeja para migas frecuentemente para evitar la acumulación de residuos.

ALMACENANDO O GUARDANDO SU HORNO TOSTADOR

Deje que el aparato se enfríe completamente antes de almacenarlo. Si va a almacenar el horno tostador por períodos prolongados, asegúrese de que no contenga partículas o residuos de alimentos. Almacene el horno tostador en un lugar seco como encima de una mesa, mostrador, o sobre una repisa. No es necesario otro tipo de mantenimiento que no sea la limpieza recomendada en este manual.

PROBLEMA	POSIBLE CAUSA/SOLUCIONES
Cocción excesiva o insuficiente de los alimentos.	Temperatura o tiempo incorrectos. ? Usted debe asegurarse que el botón de temperatura esté posicionado a la temperatura deseada. ? Debido a que su horno tostador es más pequeño que los hornos regulares este se calentará más pronto y generalmente cocinará en períodos de tiempo más cortos.
Olor a quemado.	? Si el olor se ocurre en cuando Ud usa el horno por primera vez, esto es normal. (Consulte la sección "Preparando su horno tostador" Acumulación de residuos de alimentos en el interior del horno, en los elementos calentadores o en la parrilla para migas. ? Consulte la Sección "Limpieza de Su Horno Tostador"
El horno no inicia su operación Solamente un elemento calentador se calienta. El elemento calentador no se mantiene encendido.	La unidad está desconectada. ? Enchufe el horno tostador en una toma de corriente eléctrica 120V / 60Hz . ? Asegúrese de haber seleccionado el tiempo usando la perilla de reloj. ? Coloque la perilla de la temperatura en la posición deseada. Ambas deben de girarse para poner en funcionamiento el horno tostador. La selección de la función determina cual elemento calentador operará. ? Cuando tueste alimentos, asegúrese de que el horno no se encuentre en la función de asado. Los elementos calentadores se encenderán y se apagarán para mantener la temperatura adecuada. ? Asegúrese de que la función seleccionada es la función que desea utilizar.

PRINTED IN CHINA

Free Manuals Download Website

<http://myh66.com>

<http://usermanuals.us>

<http://www.somanuals.com>

<http://www.4manuals.cc>

<http://www.manual-lib.com>

<http://www.404manual.com>

<http://www.luxmanual.com>

<http://aubethermostatmanual.com>

Golf course search by state

<http://golfingnear.com>

Email search by domain

<http://emailbydomain.com>

Auto manuals search

<http://auto.somanuals.com>

TV manuals search

<http://tv.somanuals.com>