

# 10" Table Saw

(Model 36-550)  
(Model 36-560 w/stand)



Model 36-560 with stand  
shown

PART NO. 904817 - 02-19-02  
Copyright © 2002 Delta Machinery



To learn more about DELTA MACHINERY  
visit our website at: [www.deltamachinery.com](http://www.deltamachinery.com).

For Parts, Service, Warranty or other Assistance,

please call **1-800-223-7278** (In Canada call **1-800-463-3582**).

**ESPAÑOL: PÁGINA 25**

# GENERAL SAFETY RULES

Woodworking can be dangerous if safe and proper operating procedures are not followed. As with all machinery, there are certain hazards involved with the operation of the product. Using the machine with respect and caution will considerably lessen the possibility of personal injury. However, if normal safety precautions are overlooked or ignored, personal injury to the operator may result. Safety equipment such as guards, push sticks, hold-downs, featherboards, goggles, dust masks and hearing protection can reduce your potential for injury. But even the best guard won't make up for poor judgment, carelessness or inattention. Always use common sense and exercise caution in the workshop. If a procedure feels dangerous, don't try it. Figure out an alternative procedure that feels safer. **REMEMBER:** Your personal safety is your responsibility.

This machine was designed for certain applications only. Delta Machinery strongly recommends that this machine not be modified and/or used for any application other than that for which it was designed. If you have any questions relative to a particular application, **DO NOT** use the machine until you have first contacted Delta to determine if it can or should be performed on the product.

## Technical Service Manager

Delta Machinery  
4825 Highway 45 North  
Jackson, TN 38305

(IN CANADA: 505 SOUTHGATE DRIVE, GUELPH, ONTARIO N1H 6M7)



## WARNING: FAILURE TO FOLLOW THESE RULES MAY RESULT IN SERIOUS PERSONAL INJURY

1. **FOR YOUR OWN SAFETY, READ INSTRUCTION MANUAL BEFORE OPERATING THE TOOL.** Learn the tool's application and limitations as well as the specific hazards peculiar to it.

2. **KEEP GUARDS IN PLACE** and in working order.

3. **ALWAYS WEAR EYE PROTECTION.** Wear safety glasses. Everyday eyeglasses only have impact resistant lenses; they are not safety glasses. Also use face or dust mask if cutting operation is dusty. These safety glasses must conform to ANSI Z87.1 requirements. **NOTE:** Approved glasses have Z87 printed or stamped on them.

4. **REMOVE ADJUSTING KEYS AND WRENCHES.** Form habit of checking to see that keys and adjusting wrenches are removed from tool before turning it "on".

5. **KEEP WORK AREA CLEAN.** Cluttered areas and benches invite accidents.

6. **DON'T USE IN DANGEROUS ENVIRONMENT.** Don't use power tools in damp or wet locations, or expose them to rain. Keep work area well-lighted.

7. **KEEP CHILDREN AND VISITORS AWAY.** All children and visitors should be kept a safe distance from work area.

8. **MAKE WORKSHOP CHILDPROOF** – with padlocks, master switches, or by removing starter keys.

9. **DON'T FORCE TOOL.** It will do the job better and be safer at the rate for which it was designed.

10. **USE RIGHT TOOL.** Don't force tool or attachment to do a job for which it was not designed.

11. **WEAR PROPER APPAREL.** No loose clothing, gloves, neckties, rings, bracelets, or other jewelry to get caught in moving parts. Nonslip footwear is recommended. Wear protective hair covering to contain long hair.

12. **SECURE WORK.** Use clamps or a vise to hold work when practical. It's safer than using your hand and frees both hands to operate tool.

13. **DON'T OVERREACH.** Keep proper footing and balance at all times.

14. **MAINTAIN TOOLS IN TOP CONDITION.** Keep tools sharp and clean for best and safest performance. Follow instructions for lubricating and changing accessories.

15. **DISCONNECT TOOLS** before servicing and when changing accessories such as blades, bits, cutters, etc.

16. **USE RECOMMENDED ACCESSORIES.** The use of accessories and attachments not recommended by Delta may cause hazards or risk of injury to persons.

17. **REDUCE THE RISK OF UNINTENTIONAL STARTING.** Make sure switch is in "OFF" position before plugging in power cord. In the event of a power failure, move switch to the "OFF" position.

18. **NEVER STAND ON TOOL.** Serious injury could occur if the tool is tipped or if the cutting tool is accidentally contacted.

19. **CHECK DAMAGED PARTS.** Before further use of the tool, a guard or other part that is damaged should be carefully checked to ensure that it will operate properly and perform its intended function – check for alignment of moving parts, binding of moving parts, breakage of parts, mounting, and any other conditions that may affect its operation. A guard or other part that is damaged should be properly repaired or replaced.

20. **DIRECTION OF FEED.** Feed work into a blade or cutter against the direction of rotation of the blade or cutter only.

21. **NEVER LEAVE TOOL RUNNING UNATTENDED. TURN POWER OFF.** Don't leave tool until it comes to a complete stop.

22. **STAY ALERT, WATCH WHAT YOU ARE DOING, AND USE COMMON SENSE WHEN OPERATING A POWER TOOL. DO NOT USE TOOL WHILE TIRED OR UNDER THE INFLUENCE OF DRUGS, ALCOHOL, OR MEDICATION.** A moment of inattention while operating power tools may result in serious personal injury.

23. **MAKE SURE TOOL IS DISCONNECTED FROM POWER SUPPLY** while motor is being mounted, connected or reconnected.

24. **THE DUST GENERATED** by certain woods and wood products can be injurious to your health. Always operate machinery in well ventilated areas and provide for proper dust removal. Use wood dust collection systems whenever possible.

25.  **WARNING: SOME DUST CREATED BY POWER SANDING, SAWING, GRINDING, DRILLING, AND OTHER CONSTRUCTION ACTIVITIES** contains chemicals known to cause cancer, birth defects or other reproductive harm. Some examples of these chemicals are:

- lead from lead-based paints,
  - crystalline silica from bricks and cement and other masonry products, and
  - arsenic and chromium from chemically-treated lumber.
- Your risk from these exposures varies, depending on how often you do this type of work. To reduce your exposure to these chemicals: work in a well ventilated area, and work with approved safety equipment, such as those dust masks that are specially designed to filter out microscopic particles.

**SAVE THESE INSTRUCTIONS.**

**Refer to them often and use them to instruct others.**

# ADDITIONAL SAFETY RULES FOR TABLE SAW



**WARNING: FAILURE TO FOLLOW THESE RULES MAY RESULT IN SERIOUS PERSONAL INJURY.**

1. **DO NOT OPERATE THIS MACHINE** until it is **assembled** and **installed** according to the instructions.
2. **OBTAIN ADVICE FROM YOUR SUPERVISOR, instructor, or another qualified person** if you are not familiar with the operation of this machine.
3. **FOLLOW ALL WIRING CODES** and recommended electrical connections.
4. **USE THE GUARDS WHENEVER POSSIBLE.** Check to see that they are in place, secured, and working correctly.
5. **AVOID KICKBACK by:**
  - A. keeping blade sharp and free of rust and pitch.
  - B. keeping rip fence parallel to the saw blade.
  - C. using saw blade guard and spreader for every possible operation, including all through sawing.
  - D. pushing the workpiece past the saw blade prior to release.
  - E. never ripping a workpiece that is twisted or warped, or does not have a straight edge to guide along the fence.
  - F. using feather boards when the anti-kickback device cannot be used.
  - G. never sawing a large workpiece that cannot be controlled.
  - H. never using the fence as a guide when crosscutting.
  - I. never sawing a workpiece with loose knots or other flaws.
6. **ALWAYS USE GUARDS, SPLITTER, AND ANTI-KICKBACK FINGERS** except when otherwise directed in the manual.
7. **REMOVE CUT-OFF PIECES AND SCRAPS** from the table before starting the saw. The vibration of the machine may cause them to move into the saw blade and be thrown out. After cutting, turn the machine off. When the blade has **come to a complete stop, remove all debris.**
8. **NEVER START THE MACHINE** with the workpiece against the blade.
9. **HOLD THE WORKPIECE FIRMLY** against the miter gauge or fence.
10. **NEVER** run the workpiece between the fence and a moulding cutterhead.
11. **NEVER** perform “free-hand” operations. Use either the fence or miter gauge to position and guide the workpiece.
12. **USE PUSH STICK(S)** for ripping a narrow workpiece.
13. **AVOID AWKWARD OPERATIONS AND HAND POSITIONS** where a sudden slip could cause a hand to move into the blade.
14. **KEEP ARMS, HANDS, AND FINGERS** away from the blade.
15. **NEVER** have any part of your body in line with the path of the saw blade.
16. **NEVER REACH AROUND** or over the saw blade.
17. **NEVER** attempt to free a stalled saw blade without first turning the machine “OFF”.
18. **PROPERLY SUPPORT LONG OR WIDE** workpieces.
19. **NEVER PERFORM LAYOUT,** assembly or set-up work on the table/work area when the machine is running.
20. **TURN THE MACHINE “OFF” AND DISCONNECT THE MACHINE** from the power source before installing or removing accessories, before adjusting or changing set-ups, or when making repairs.
21. **TURN THE MACHINE “OFF”,** disconnect the machine from the power source, and clean the table/work area before leaving the machine. **LOCK THE SWITCH IN THE “OFF” POSITION** to prevent unauthorized use.
22. **ADDITIONAL INFORMATION** regarding the safe and proper operation of this tool is available from the Power Tool Institute, 1300 Summer Avenue, Cleveland, OH 44115-2851. Information is also available from the National Safety Council, 1121 Spring Lake Drive, Itasca, IL 60143-3201. Please refer to the American National Standards Institute ANSI 01.1 Safety Requirements for Woodworking Machines and the U.S. Department of Labor OSHA 1910.213 Regulations.

**SAVE THESE INSTRUCTIONS.  
Refer to them often  
and use them to instruct others.**

# POWER CONNECTIONS

A separate electrical circuit should be used for your machines. This circuit should not be less than #12 wire and should be protected with a 20 Amp time lag fuse. If an extension cord is used, use only 3-wire extension cords which have 3-prong grounding type plugs and matching receptacle which will accept the machine's plug. Before connecting the motor to the power line, make sure the switch is in the "OFF" position and be sure that the electric current is of the same characteristics as indicated on the machine. All line connections should make good contact. Running on low voltage will damage the motor.

 **WARNING: DO NOT EXPOSE THE MACHINE TO RAIN OR OPERATE THE MACHINE IN DAMP LOCATIONS.**

## MOTOR SPECIFICATIONS

Your machine is wired for 120 volt, 60 HZ alternating current. Before connecting the machine to the power source, make sure the switch is in the "OFF" position.

## GROUNDING INSTRUCTIONS

 **WARNING: THIS MACHINE MUST BE GROUNDED WHILE IN USE TO PROTECT THE OPERATOR FROM ELECTRIC SHOCK.**

1. All grounded, cord-connected machines:

In the event of a malfunction or breakdown, grounding provides a path of least resistance for electric current to reduce the risk of electric shock. This machine is equipped with an electric cord having an equipment-grounding conductor and a grounding plug. The plug must be plugged into a matching outlet that is properly installed and grounded in accordance with all local codes and ordinances.

Do not modify the plug provided - if it will not fit the outlet, have the proper outlet installed by a qualified electrician.

Improper connection of the equipment-grounding conductor can result in risk of electric shock. The conductor with insulation having an outer surface that is green with or without yellow stripes is the equipment-grounding conductor. If repair or replacement of the electric cord or plug is necessary, do not connect the equipment-grounding conductor to a live terminal.

Check with a qualified electrician or service personnel if the grounding instructions are not completely understood, or if in doubt as to whether the machine is properly grounded.

Use only 3-wire extension cords that have 3-prong grounding type plugs and matching 3-conductor receptacles that accept the machine's plug, as shown in Fig. A.

Repair or replace damaged or worn cord immediately.

2. Grounded, cord-connected machines intended for use on a supply circuit having a nominal rating less than 150 volts:

If the machine is intended for use on a circuit that has an outlet that looks like the one illustrated in Fig. A, the machine will have a grounding plug that looks like the plug illustrated in Fig. A. A temporary adapter, which looks like the adapter illustrated in Fig. B, may be used to connect this plug to a matching 2-conductor receptacle as shown in Fig. B if a properly grounded outlet is not available. The temporary adapter should be used only until a properly grounded outlet can be installed by a qualified electrician. The green-colored rigid ear, lug, and the like, extending from the adapter must be connected to a permanent ground such as a properly grounded outlet box. Whenever the adapter is used, it must be held in place with a metal screw.

**NOTE: In Canada, the use of a temporary adapter is not permitted by the Canadian Electric Code.**

 **WARNING: IN ALL CASES, MAKE CERTAIN THE RECEPTACLE IN QUESTION IS PROPERLY GROUNDED. IF YOU ARE NOT SURE HAVE A QUALIFIED ELECTRICIAN CHECK THE RECEPTACLE.**

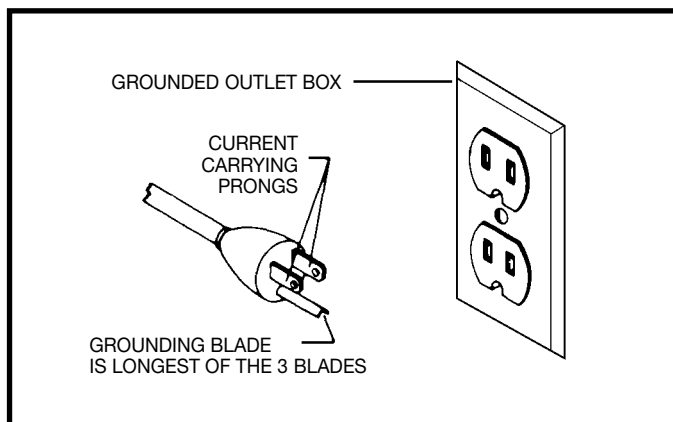

Fig. A

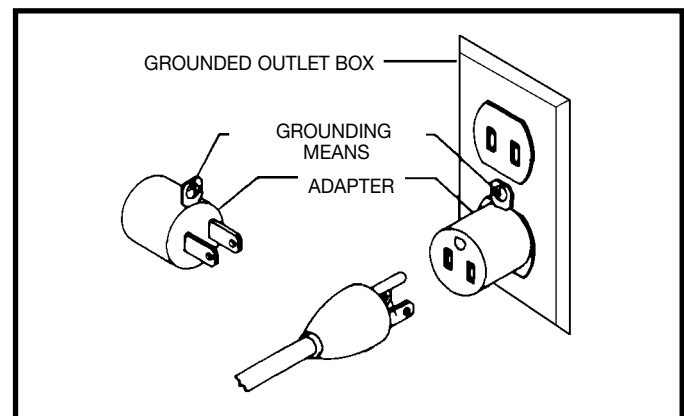

Fig. B

# EXTENSION CORDS

Use proper extension cords. Make sure your extension cord is in good condition and is a 3-wire extension cord which has a 3-prong grounding type plug and matching receptacle which will accept the machine's plug. When using an extension cord, be sure to use one heavy enough to carry the current of the machine. An undersized cord will cause a drop in line voltage, resulting in loss of power and overheating. Fig. D, shows the correct gauge to use depending on the cord length. If in doubt, use the next heavier gauge. The smaller the gauge number, the heavier the cord.

<b>MINIMUM GAUGE EXTENSION CORD</b>			
RECOMMENDED SIZES FOR USE WITH STATIONARY ELECTRIC MACHINES			
Ampere Rating	Volts	Total Length of Cord in Feet	Gauge of Extension Cord
0-6	115	up to 25	18 AWG
0-6	115	25-50	16 AWG
0-6	115	50-100	16 AWG
0-6	115	100-150	14 AWG
6-10	115	up to 25	18 AWG
6-10	115	25-50	16 AWG
6-10	115	50-100	14 AWG
6-10	115	100-150	12 AWG
10-12	115	up to 25	16 AWG
10-12	115	25-50	16 AWG
10-12	115	50-100	14 AWG
10-12	115	100-150	12 AWG
12-16	115	up to 25	14 AWG
12-16	115	25-50	12 AWG
12-16	115	GREATER THAN 50 FEET NOT RECOMMENDED	

Fig. D

# OPERATING INSTRUCTIONS

## FOREWORD

Delta Models 36-560 & 36-550 are table saws that have a "Big saw capacity" at an economical price. The Delta Models 36-560 & 36-550 have an extra large, 17½"x34" solid anodized aluminum table. The Delta Models 36-560 & 36-550 are powered by a heavy-duty 15 amp. motor with a floating jackshaft gear, which is the most powerful in its class.

## UNPACKING AND CLEANING

Carefully unpack the machine and all loose items from the shipping container(s). Remove the protective coating from all unpainted surfaces. This coating may be removed with a soft cloth moistened with kerosene (do not use acetone, gasoline or lacquer thinner for this purpose). After cleaning, cover the unpainted surfaces with a good quality household floor paste wax.

## TABLE SAW PARTS

- 1- Saw
- 2- Extension Wing
- 3- 1/4"- Flat Washer for Mounting Extension Wing (3)
- 4- 1/4"- Lockwasher for Mounting Extension Wing (3)
- 5- 1/4-20 x 5/8" Hex Head Screw for Mounting Extension Wing (3)

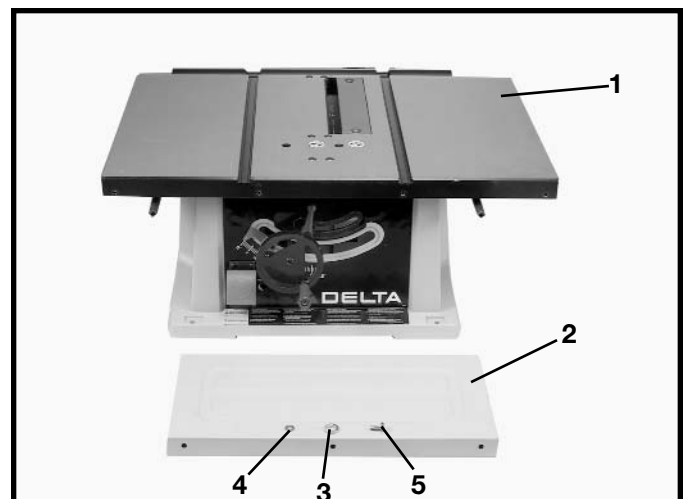

Fig. 2



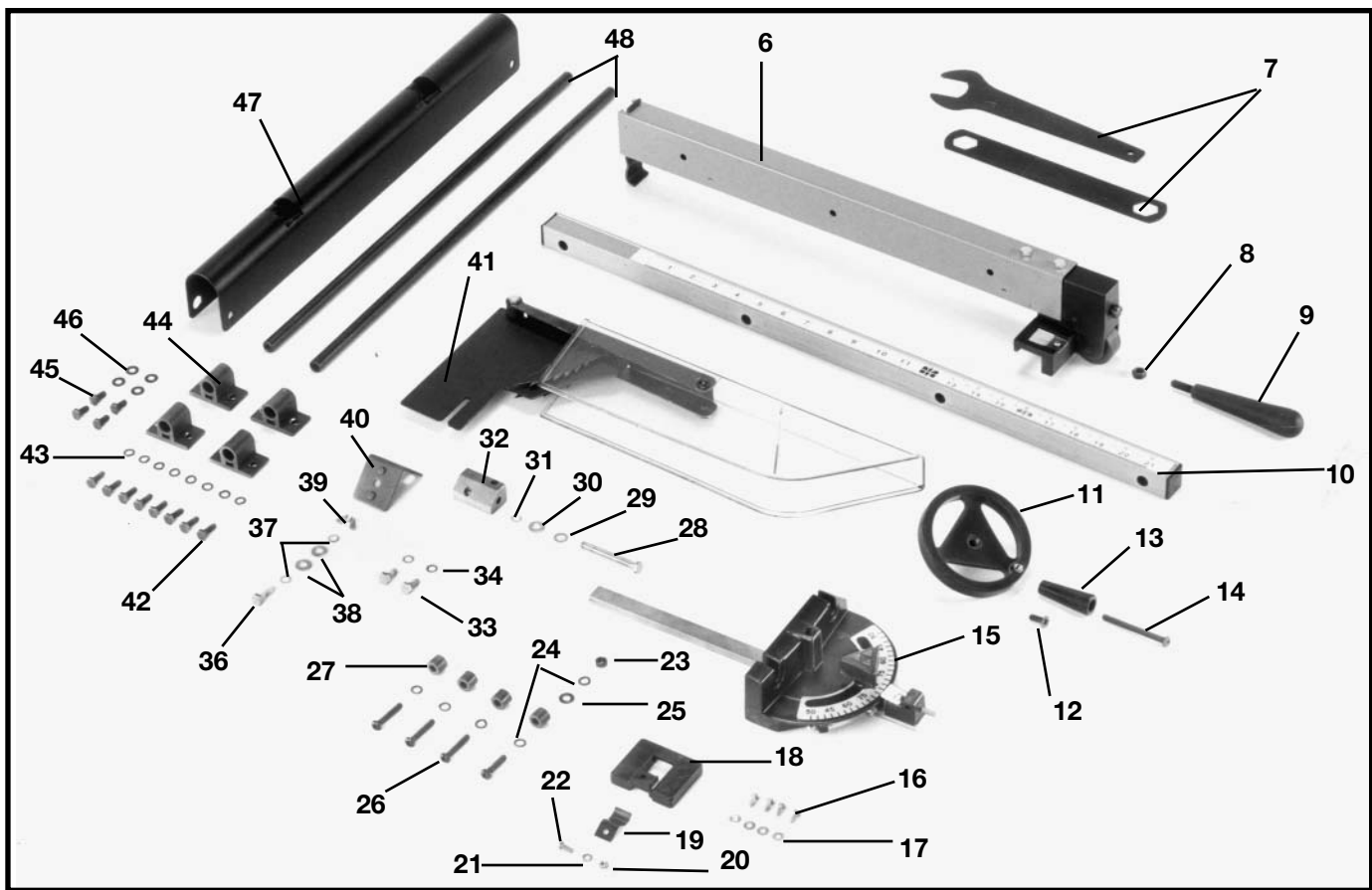

Fig. 3

- 6 - Rip Fence
- 7 - Wrenches for Blade Changing
- 8 - M8 Hex Nut for Rip Fence
- 9 - Locking Handle for Rip Fence
- 10 - Fence Rail
- 11 - Blade Raising and Lowering Handwheel
- 12 - M6 x 12mm Flat Head Screw for Mounting Blade Raising and Lowering Handwheel
- 13 - Handle for Blade Raising and Lowering Handwheel
- 14 - M6 x 55mm Cheese Head Screw for Mounting Handwheel Handle
- 15 - Miter Gage
- 16 - M4.2 x10mm Pan Head Screws for Mounting miter gage Holder (4)
- 17 - 3/16" Flat Washers for Mounting Miter Gage Holder (4)
- 18 - Miter Gage Holder
- 19 - Spring Clip for Miter Gage Holder
- 20 - M4 Hex Nut for Miter Gage Holder
- 21 - 3/16" External Tooth Lockwasher for Miter Gage Holder
- 22 - M4 x 10mm Pan Head Screw for Miter Gage Holder
- 23 - 1/4-20 Hex Nut for Mounting Fence Rail to Extension Wing
- 24 - 1/4" Lockwashers for Mounting Fence Rail (5)
- 25 - 1/4" Flat Washer for Mounting Fence Rail to Extension Wing
- 26 - 1/4-20 x 1-1/4" Round Head Screws for Mounting Fence Rail (4)
- 27 - Spacer for Mounting Fence Rail (4)
- 28 - 1/4-20 x 2-1/4" Long Hex Head Screw for Mounting Splitter Bracket
- 29 - 1/4" Internal Tooth Lockwasher for Mounting Splitter Bracket
- 30 - 1/4" Flat Washer for Mounting Splitter Bracket
- 31 - 1/4" External Tooth Lockwasher for Mounting Splitter Bracket
- 32 - Splitter Bracket
- 33 - 1/4-20 x 1/2" Hex Head Screws for Splitter Bracket (2)
- 34 - 1/4" External Tooth Lockwashers for Splitter Bracket (2)
- 36 - M6 x 20mm Hex Head Screw for Mounting Splitter Support Bracket
- 37 - 1/4" External Tooth Washers for Mounting Splitter Support Bracket (2)
- 38 - 1/4" Flat Washers for Mounting Splitter Support Bracket (2)
- 39 - Wing Nut for Mounting Splitter Support Bracket
- 40 - Splitter Support Bracket
- 41 - Splitter and Guard Assembly
- 42 - M6 x 15mm Hex Head Screw for Mounting Outfeed Support Brackets (8)
- 43 - Flat Washer for Mounting Outfeed Support Brackets (8)
- 44 - Outfeed Support Bracket (4)
- 45 - 1/4-20x1/2" Hex Head Screw for Mounting Rear Support onto Support Rods (4)
- 46 - 1/4" Flat Washer for Mounting Rear Support onto Support Rods (4)
- 47 - Rear Support
- 48 - Support Rod (2)

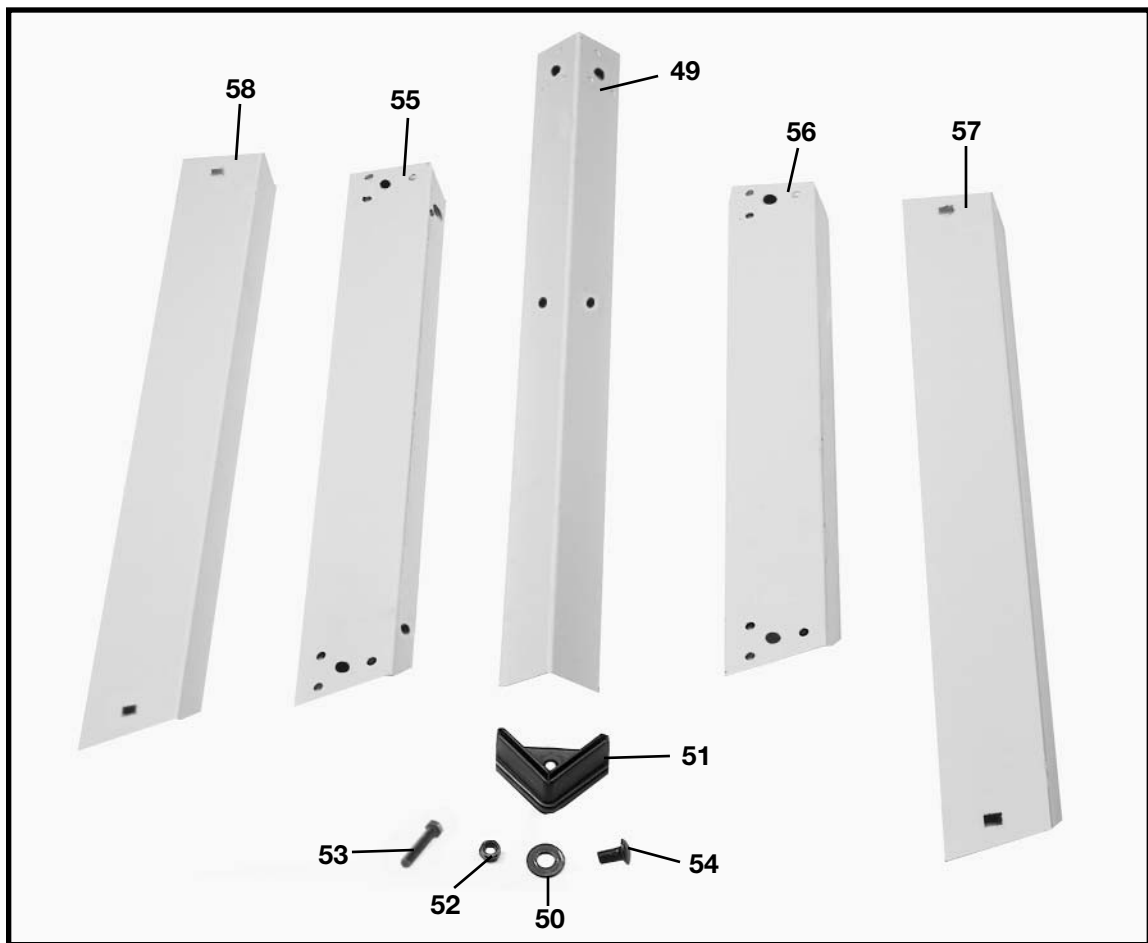

Fig. 4

## FOR MODEL 36-560 ONLY

49 - Leg (4)

50 - 3/8" Flat Washer for Mounting Saw to Stand & for Assembling Stand (24)

51 - Foot (4)

52 - M8 Hex Nut for Mounting Saw to Stand & for Assembling Stand (20)

53 - M8 x 40mm Hex Screw for Mounting Saw to Stand (4)

54 - M8 x 20mm Carriage Bolts for Assembling Stand (16)

55 - 18-1/2" Top Front and Rear Brackets (2)

56 - 17" Top Side Brackets (2)

57 - 22" Bottom Front and Rear Brackets (2)

58 - 20-3/8" Bottom Side Brackets (2)

# ASSEMBLY

## ASSEMBLING BLADE RAISING AND LOWERING HANDWHEEL

1. Insert M6 x 55mm cheese head screw (14) Fig. 3, through handle (E) Fig. 5 and assemble handle (E) to handwheel (A) by threading screw (D) Fig. 5 clockwise into handwheel.

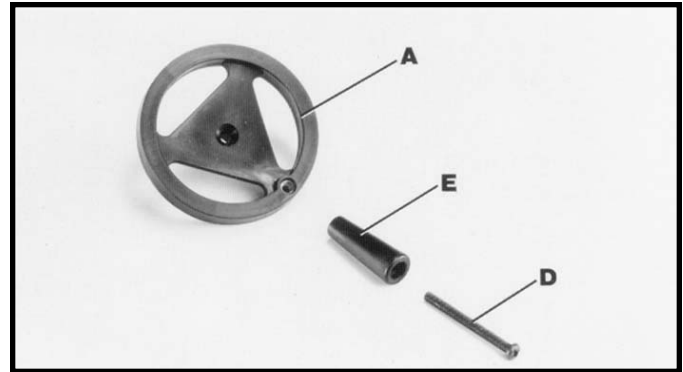

Fig. 5

2. Fig. 6, illustrates the handle (E) assembled to handwheel (A).

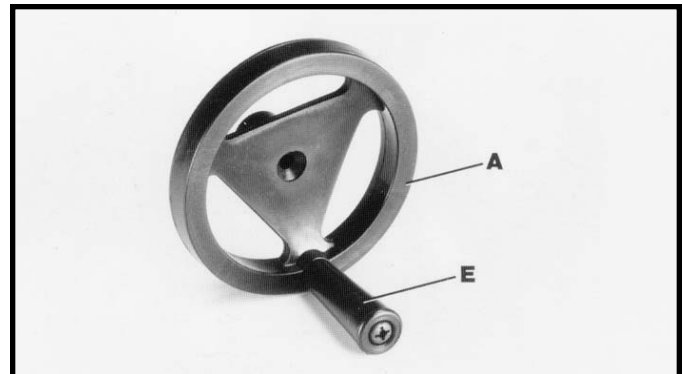

Fig. 6

3. Assemble handwheel (A) Fig. 7, to shaft (B) making sure the flat on inside of handwheel lines up with flat on shaft.



Fig. 7

4. Fasten handwheel (A) Fig. 8, to shaft (B) Fig. 7, using a M6 x 12mm flat head screw (C) Fig. 8.



Fig. 8



# ASSEMBLING BLADE GUARD AND SPLITTER ASSEMBLY

1. DISCONNECT MACHINE FROM POWER SOURCE.

2. **IMPORTANT: THE BLADE GUARD AND SPLITTER ASSEMBLY MUST BE PROPERLY ALIGNED TO THE SAW BLADE IN ORDER TO PREVENT KICKBACK.**

3. Position the blade 90 degrees to the table and lock in place.

4. Fasten the splitter support bracket (A) Fig. 9, to splitter bracket (B) using two 1/4-20 x 1/2" Hex Head Screws (C) which were removed from splitter bracket (B) earlier, and two 1/4" external tooth lockwashers as shown. **NOTE: Do not completely tighten screws (C) at this time.**

5. Locate the 1/4-20 x 2-1/4" hex head screw (G) Fig. 10, and assemble the 1/4" internal tooth lockwasher (O), 1/4" flat washer (P) and 1/4" external tooth lockwasher (R) onto screw (G).

6. Position recessed end (E) Fig. 11, of splitter bracket (B) against end of pivot rod (F) and fasten in place using the 1/4-20 x 2-1/4" hex head screw (G) Fig. 12, 1/4" internal tooth lockwasher, 1/4" flat washer and 1/4" external tooth lockwasher which were assembled to screw (G) in **STEP 5. NOTE: Do not completely tighten screws (G) at this time.**

7. Position the splitter (H) Fig. 13, on the splitter support bracket as shown, making certain the two protrusions (K) on the splitter support bracket are inside the slot of splitter (H).

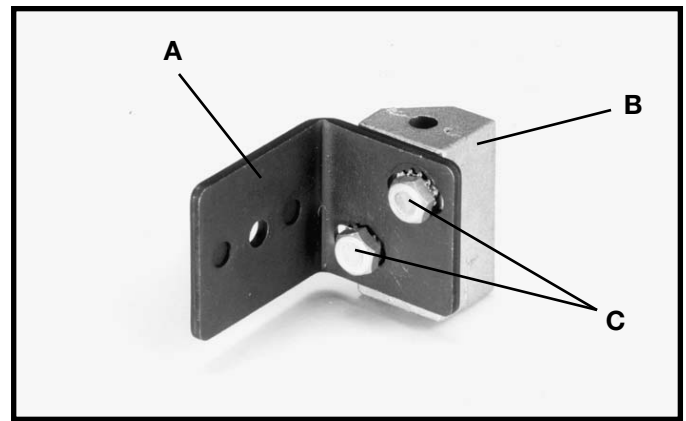

Fig. 9

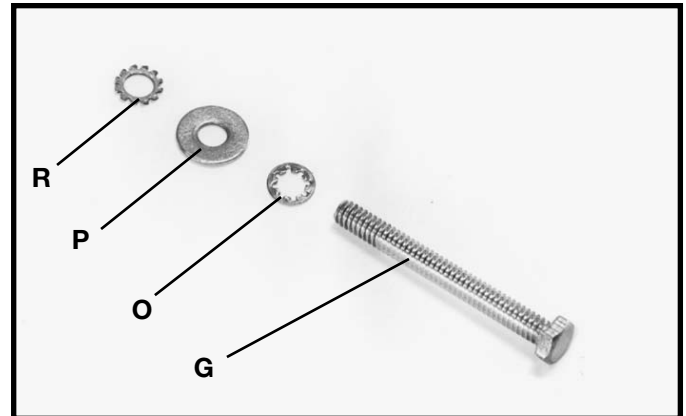

Fig. 10

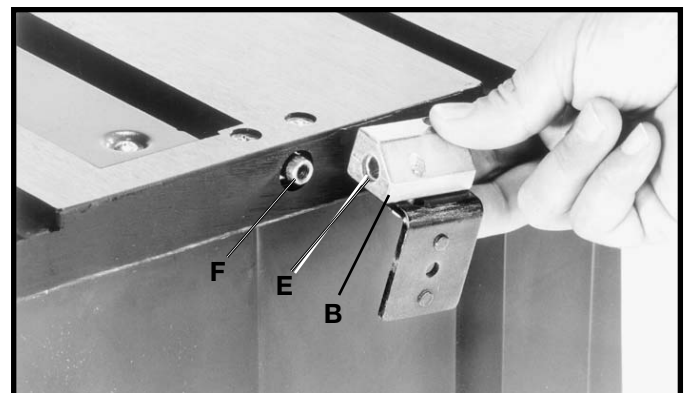

Fig. 11

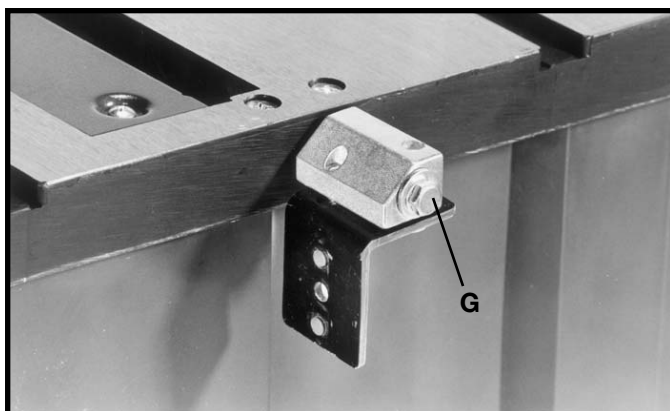

Fig. 12

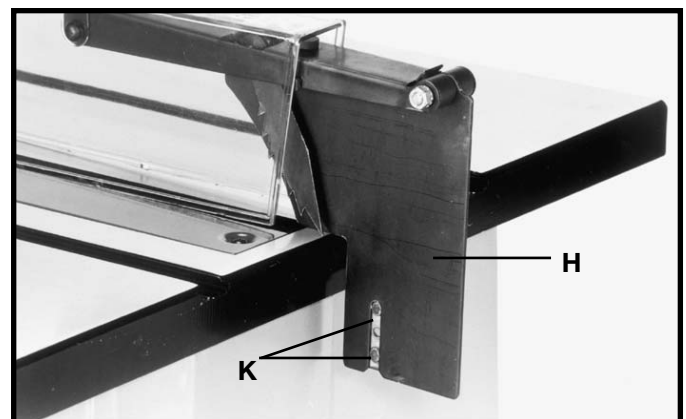

Fig. 13

8. Assemble splitter (H) Fig. 14, to splitter support bracket (B) as shown using M6 x 20mm hex head screw (L), 1/4" external tooth washer, and 1/4" flat washer.

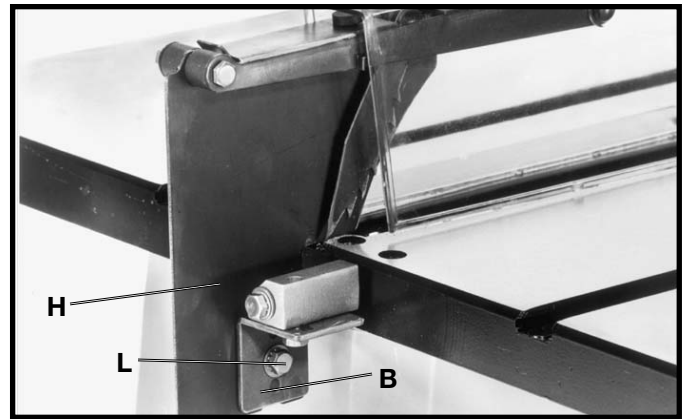

Fig. 14

9. Fasten splitter (H) Fig. 15, to splitter support bracket using 1/4" flat washer, 1/4" external tooth lockwasher and M6 wing nut (M). **NOTE:** Before tightening wing nut (M) make certain there is at least a 1/8" gap between the bottom edge of splitter (N) and top surface of table (P) and that protrusion "pins" (K) Fig. 14, are inside the slot of splitter assembly (H).

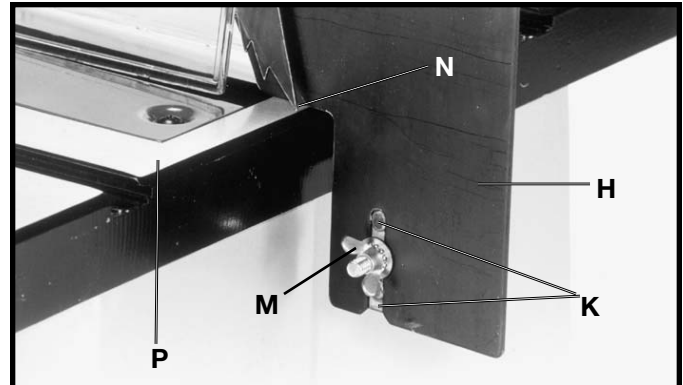

Fig. 15

10. Using a straight edge, check to see if the splitter (H) Fig. 16, is aligned with the saw blade (R). If an adjustment is necessary, the splitter (H) can be moved left or right and rotated.

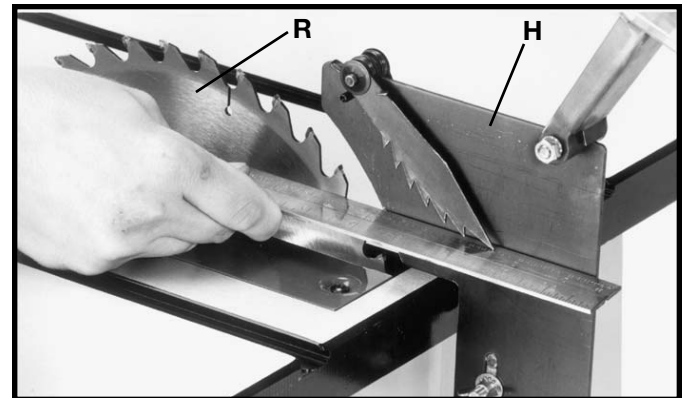

Fig. 16

11. When you are certain the splitter is properly aligned with the saw blade, tighten the two screws (C) Fig. 17, that fasten the splitter support bracket to the splitter bracket and tighten screw (G) that fastens the splitter bracket to the pivot rod.

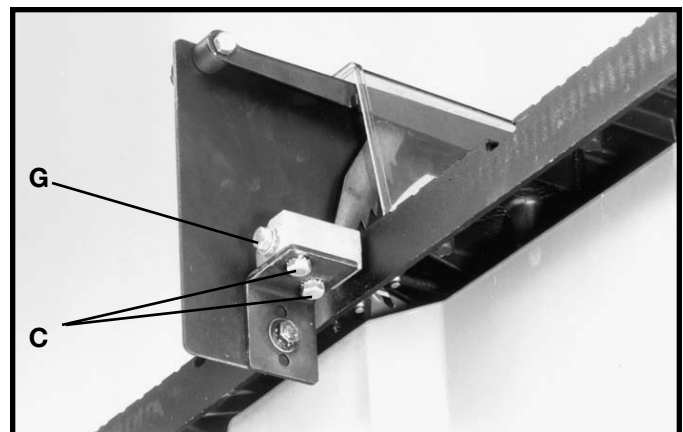

Fig. 17

## ASSEMBLING EXTENSION WING

1. Assemble extension wing (A) Fig. 18, to the saw table using three 1/4-20 x 5/8" hex head screws (B), 1/4" lockwashers (C), and 1/4" flat washers (D).
2. With a straight edge (E) Fig. 19, make certain the top, front and rear edges of the extension wing (A) are level with the saw table before tightening three screws which secure extension wing to saw table.

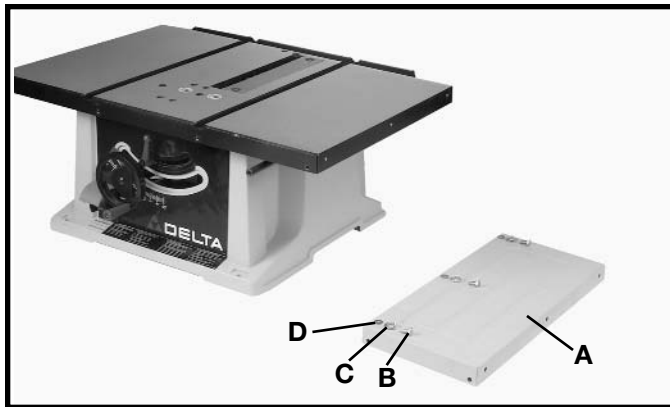

Fig. 18

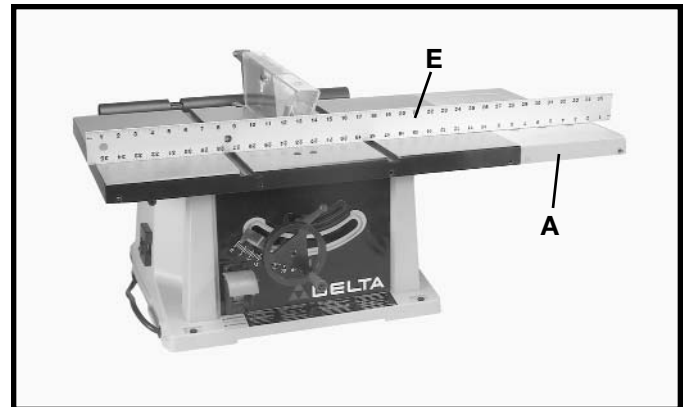

Fig. 19

## ASSEMBLING GUIDE RAIL TO SAW

1. Loosely fasten guide rail (A) Fig. 20, to three threaded holes (B) in saw table (C) using three 1/4-20 x 1-1/4" long screws (D), 1/4" lockwashers (E), and spacers (F). **IMPORTANT: Spacers (F) Fig. 20, are positioned between guide rail (A) and saw table (C).**

2. Fasten guide rail (A) Fig. 20, to extension wing (G) through hole (K) using the 1/4-20 x 1-1/4" long screw (D), 1/4" lockwasher (E), spacer (F), 1/4" flat washer (H), 1/4" lockwasher (E), and 1/4-20 hex nut (J). Then tighten all guide rail mounting hardware.

**IMPORTANT: Spacers (F) Fig. 20, are positioned between guide rail (A) and extension wing (G).**

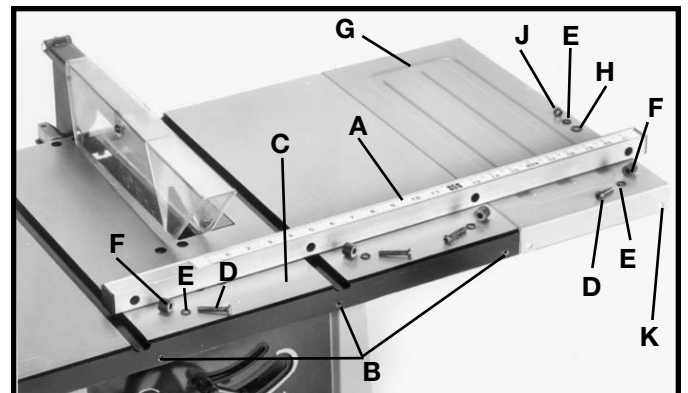

Fig. 20

3. Fig. 21, illustrates the guide rail properly assembled to saw table and extension wing.



Fig. 21

## ASSEMBLING RIP FENCE

1. Thread an M8 hex nut (A) Fig. 22, approximately halfway onto stud of handle (B).
2. Thread handle (B) Fig. 22, into tapped hole (C) in fence cam (D). Tighten hex nut (A) Fig. 23, against cam (D).

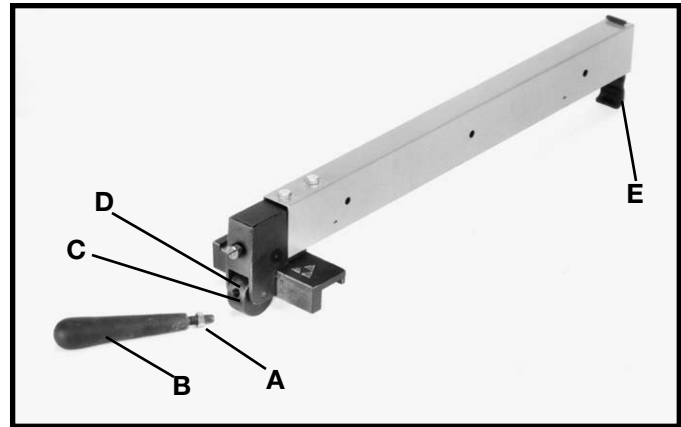

Fig. 22

3. Lower rip fence onto table as shown in Fig. 24, making certain rear clamp (E) Fig. 22, hooks over back edge of table.

4. The rip fence is usually operated on the right hand side of the saw table. Lift lock handle (B) Fig. 24, and position fence on table as shown. Push downward on handle (B) Fig. 24, to lock fence in place on saw table.

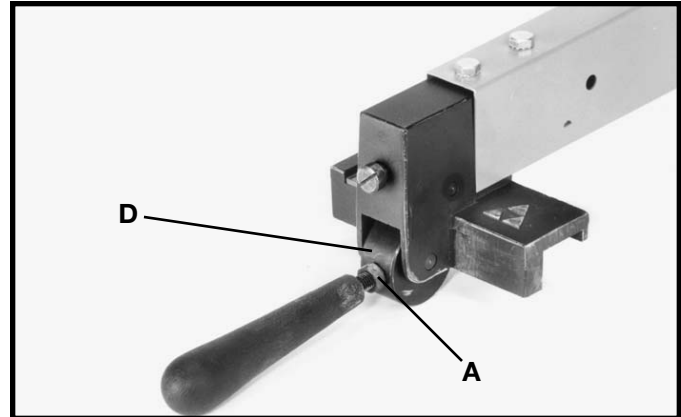

Fig. 23

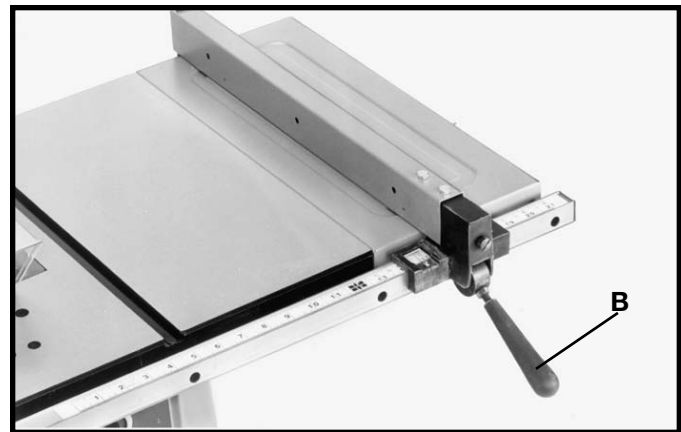

Fig. 24

## MITER GAGE

The miter gage is shipped completely assembled and is supplied with a T-slot miter gage bar (A) Fig. 25, that is inserted into either one of the two T-slotted miter gage grooves located in the table top, as shown. The T-slot miter gage prevents the miter gage from falling when it is extended out beyond the front of the table when cross-cutting extra wide workpieces.

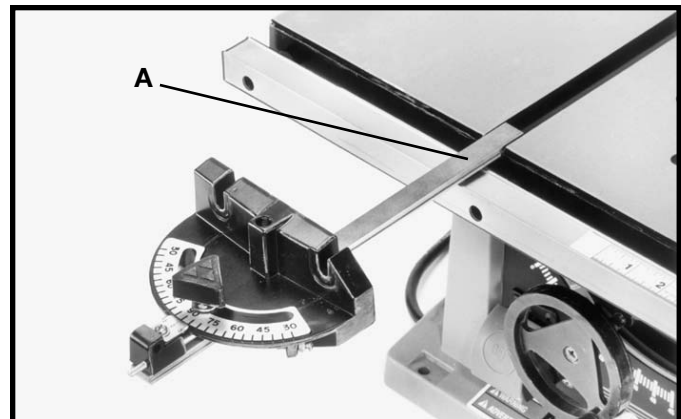

Fig. 25



# ASSEMBLING MITER GAGE HOLDER

1. DISCONNECT MACHINE FROM POWER SOURCE.

2. Assemble spring clip (E) Fig. 26, to the miter gage holder (A) as shown using a M4x10mm pan head screw (F), 3/16" lockwasher and M4 hex nut. **NOTE:** Hex nut (G) Fig. 27, will fit into the recess at the back of the miter gage holder (A) to keep spring clip (E) Fig. 26, secured to the miter gage holder.

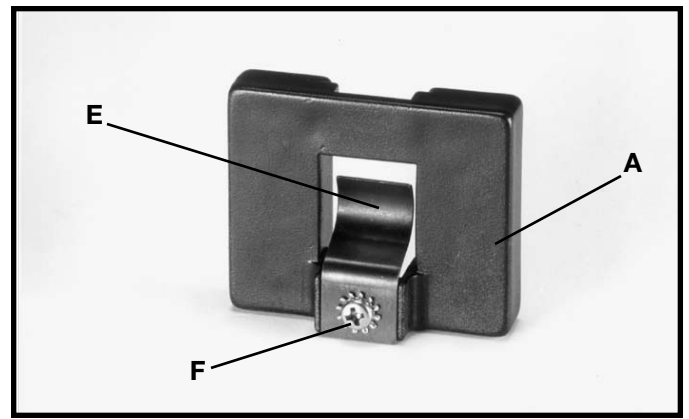

Fig. 26

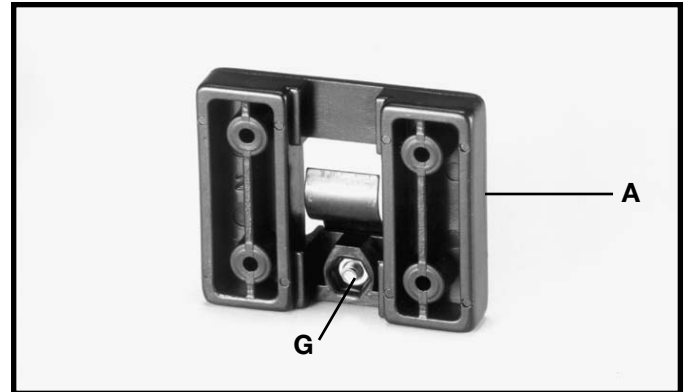

Fig. 27

3. Assemble the miter gage holder (A) Fig. 28, to the left side of the saw cabinet using the four M4.2x10mm pan head screws (B) Fig. 29, and 3/16" washers (C) from inside saw cabinet.

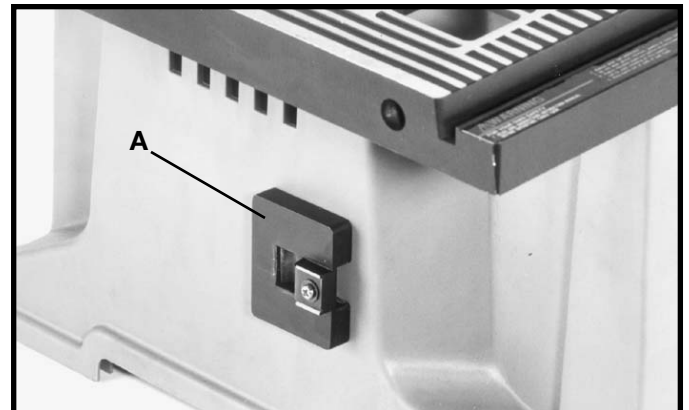

Fig. 28

4. Fig. 30, illustrates the miter gage (D) inserted into the miter gage holder when not in use.

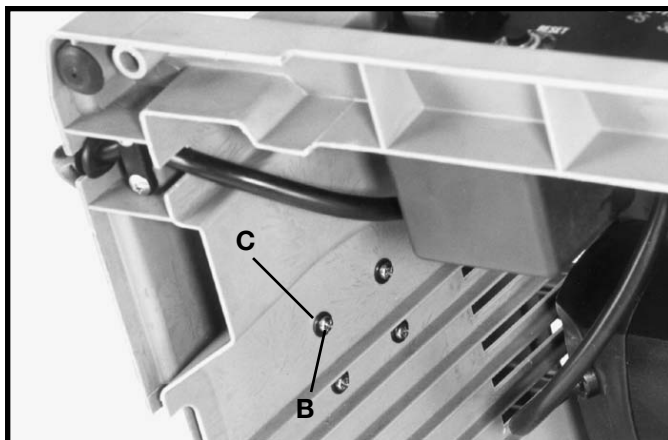

Fig. 29

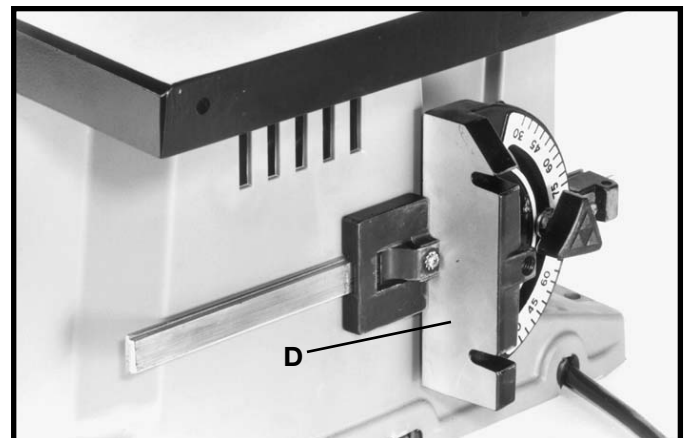

Fig. 30

# ASSEMBLING OUTFEED SUPPORT

1. Loosely fasten brackets (A) Fig. 31, to the bottom left side of the saw table as shown, using two M6x15mm hex head screws (B) and M6.1 lockwashers (C). Assemble two remaining brackets to the bottom right side of saw table in the same manner.

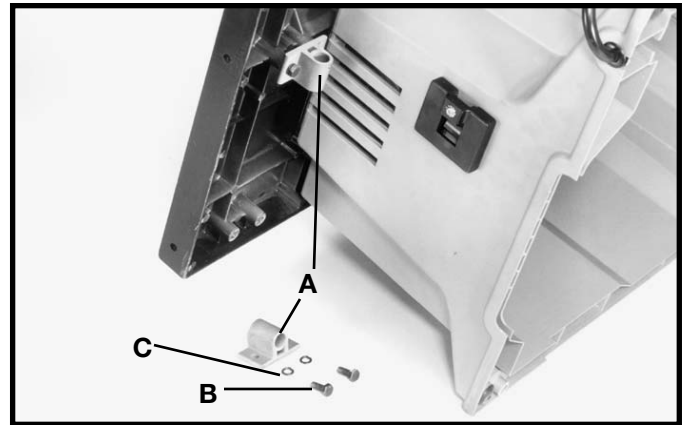

Fig. 31

2. Insert rod (D) Fig. 32, through holes in brackets (A) as shown. Then thread and tighten one 1/4-20x1/2" hex head screw (E) and 1/4" flat washer (F) into the front end of rod (D) as shown at (G). Assemble remaining rod to the opposite side of saw in the same manner.

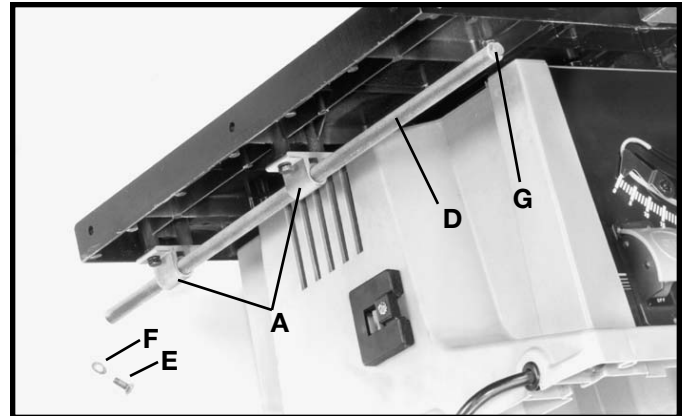

Fig. 32

3. Insert rods (D) Fig. 33, into larger holes (H) in outfeed support (J) as shown.

4. Secure outfeed support (J) Fig. 34, to rods (D) using two 1/4-20x1/2" hex head screws and 1/4" flat washers (K) as shown.

5. Push entire outfeed support assembly (J) Fig. 35, in until it contacts splitter/guard assembly (L) as shown. Then tighten all outfeed support mounting hardware.

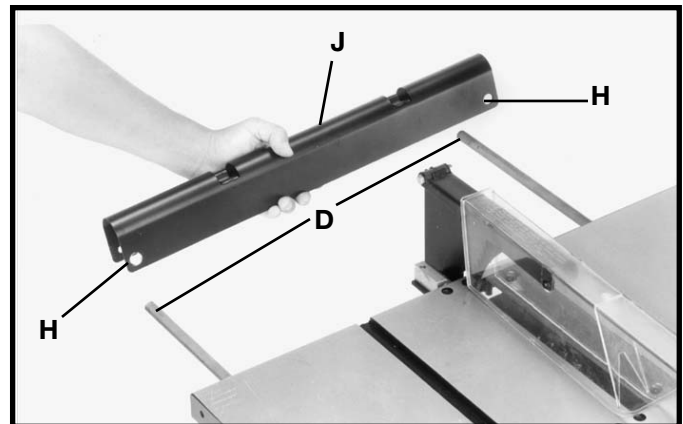

Fig. 33

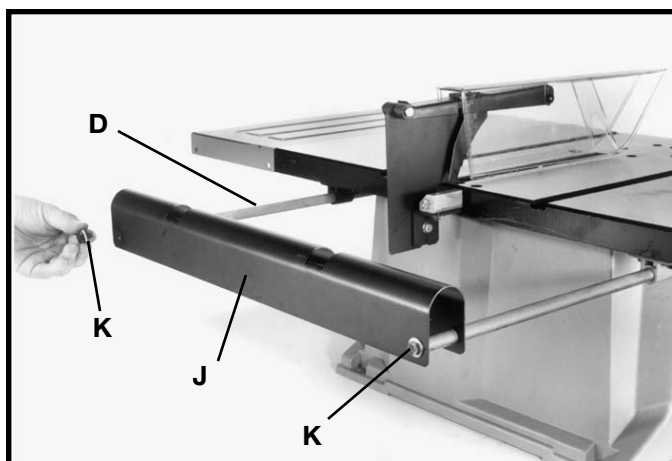

Fig. 34

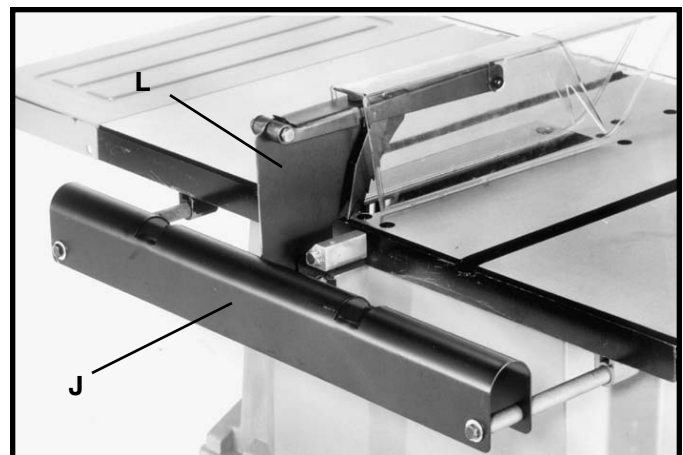

Fig. 35





# OPERATING CONTROLS AND ADJUSTMENTS

## STARTING AND STOPPING SAW

1. The on/off switch is located underneath the switch shield (A) Fig. 41. To turn the saw **"ON"**, move switch trigger (B) to the up position.

2. To turn the saw **"OFF"**, push down on switch shield (A) Fig. 42.

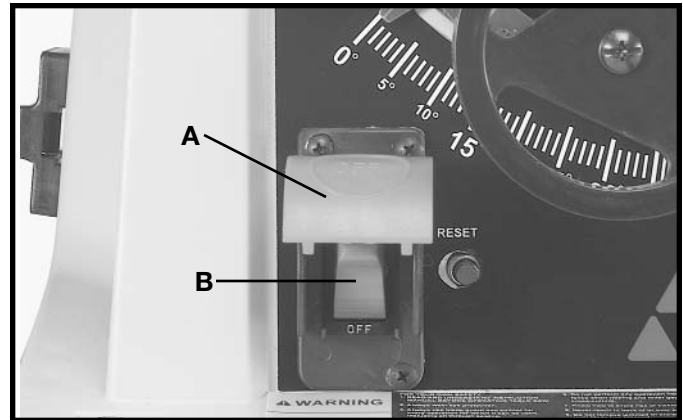

Fig. 41

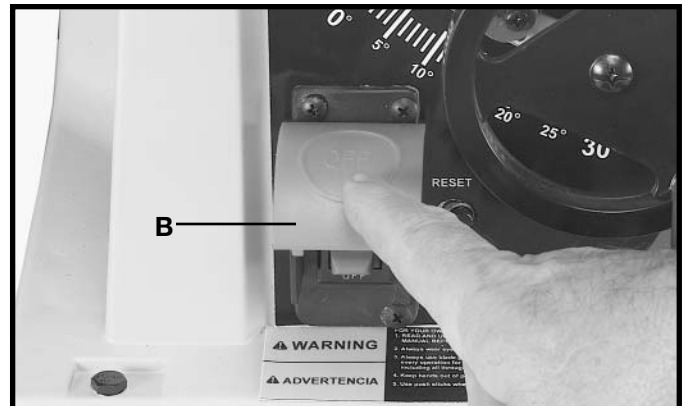

Fig. 42

## LOCKING SWITCH IN THE "OFF" POSITION

**IMPORTANT:** When the tool is not in use, the switch should be locked in the OFF position using a padlock (C) Fig. 43, with a 3/16" diameter shackle to prevent unauthorized use.

## OVERLOAD PROTECTION

Your saw is equipped with a reset overload relay button (C) Fig. 44. If the motor shuts off or fails to start due to over loading (cutting stock too fast, using a dull blade, using the saw beyond its capacity, etc.) or low voltage, turn the switch to the **"OFF"** position. Let the motor cool three to five minutes and push the reset button (C), which will reset the overload device. The motor can then be turned on again in the usual manner.

## BLADE RAISING AND LOWERING CONTROL

To raise or lower the saw blade, turn handwheel (A) Fig. 44. Turning the handwheel clockwise lowers the blade and turning the handwheel counterclockwise raises the blade. **⚠️WARNING: THE BLADE TILTING LOCK HANDLE (B) FIG. 44, MUST BE LOCKED DURING ALL CUTTING OPERATIONS.**



Fig. 43

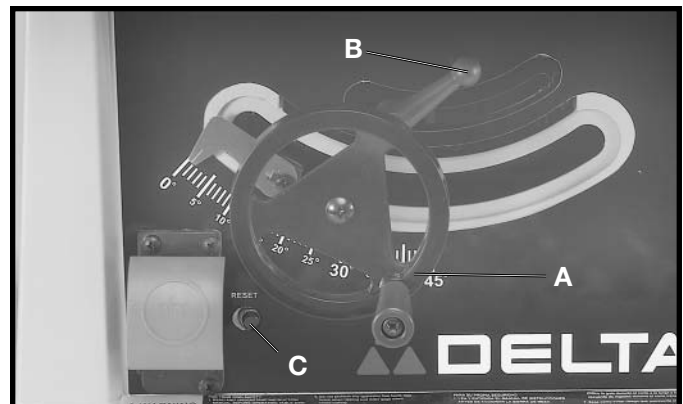

Fig. 44

# BLADE TILTING CONTROL

To tilt the saw blade, loosen blade tilting lock handle (A) Fig. 45, move handwheel (B) until the blade is at the desired angle and tighten lock handle (A). **NOTE:** The lock handle (A) is spring-loaded and can be repositioned by pulling out on the handle (A) and repositioning it on the serrated stud located underneath the handle. **WARNING: THE BLADE TILTING LOCK HANDLE (A) MUST BE LOCKED DURING ALL CUTTING OPERATIONS.**

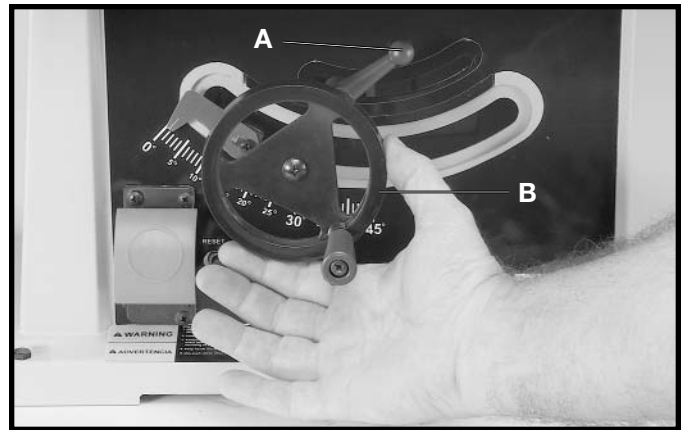

Fig. 45

## ADJUSTING 90 AND 45 DEGREE POSITIVE STOPS

Your saw is equipped with positive stops for rapid and accurate positioning of the saw blade at 90 and 45 degrees to the table. To adjust the positive stops, proceed as follows:

1. **DISCONNECT MACHINE FROM POWER SOURCE.**
2. Raise the saw blade to its maximum height.

### TO ADJUST POSITIVE STOP AT 90 DEGREES

3. Loosen the blade tilting lock handle, move the blade tilting mechanism as far as possible to the left and tighten the blade tilting lock handle.

4. Place a square (A) Fig. 46, on the table with one end of the square against the blade, as shown, and check to see if the blade is at 90 degrees to the table. If it is not, loosen screw (B) a few turns and move the blade tilting mechanism until the blade is at 90 degrees to the table. Then tighten blade tilting lock handle and tighten screw (B) until it bottoms.

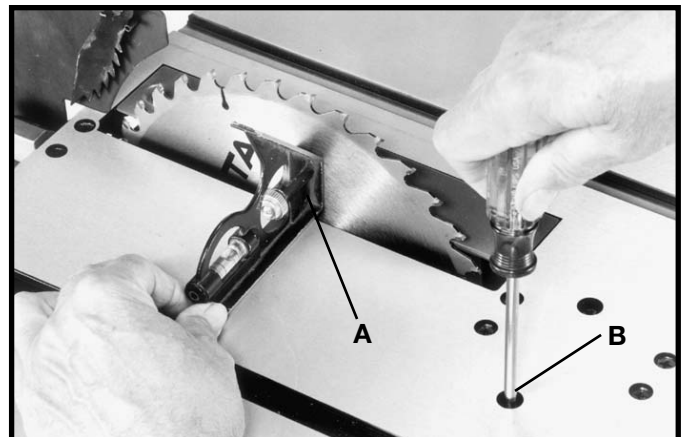

Fig. 46

### TO ADJUST POSITIVE STOP AT 45 DEGREES

5. Loosen the blade tilting lock handle, move the blade tilting mechanism as far as possible to the right and tighten the blade tilting lock handle.

6. Place a square (A) Fig. 47, on the table with one end of the square against the blade as shown, and check to see if the blade is at 45 degrees to the table. If it is not, loosen screw (C) a few turns and move the blade tilting mechanism until the blade is at 45 degrees to the table. Then tighten blade tilting lock handle and tighten screw (C) until it bottoms.

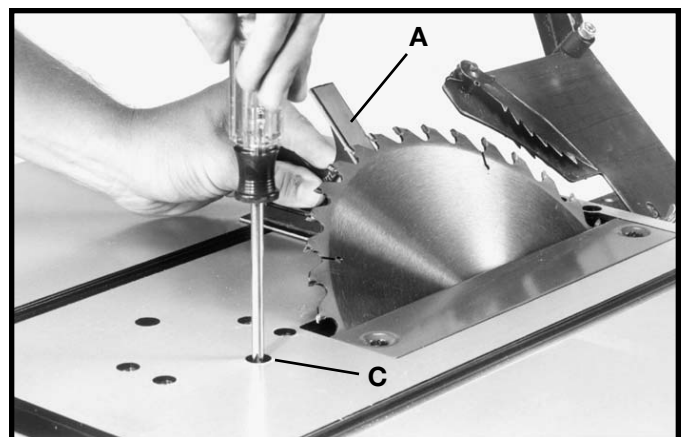

Fig. 47

# RIP FENCE OPERATION AND ADJUSTMENTS

1. To move the rip fence (A) Fig. 48, along the table, lift up fence locking lever (B), slide the fence to the desired location on the table and push down fence locking lever (B) to lock the fence in position.
2. A pointer is supplied to indicate the distance the fence is positioned away from the saw blade. If an adjustment to the pointer is required, loosen the screw (C) Fig. 48, that fastens the pointer to the fence bracket and adjust the pointer accordingly. Then, tighten screw (C).
3. **IMPORTANT: THE RIP FENCE MUST BE PROPERLY ALIGNED TO THE MITER GAGE SLOT IN ORDER TO PREVENT KICKBACK WHEN RIPPING.**
4. The saw blade is set parallel to the miter gage slot at the factory and the fence must be parallel to the miter gage slot in order to do accurate work and prevent kickback when ripping. To check the alignment:
5. Position the fence at one end of the miter gage slot, as shown in Fig. 48. Clamp the fence to the table by pushing down the locking lever (B). The edge of the fence should then line up parallel with the miter gage slot.
6. If an adjustment is necessary, proceed as follows:

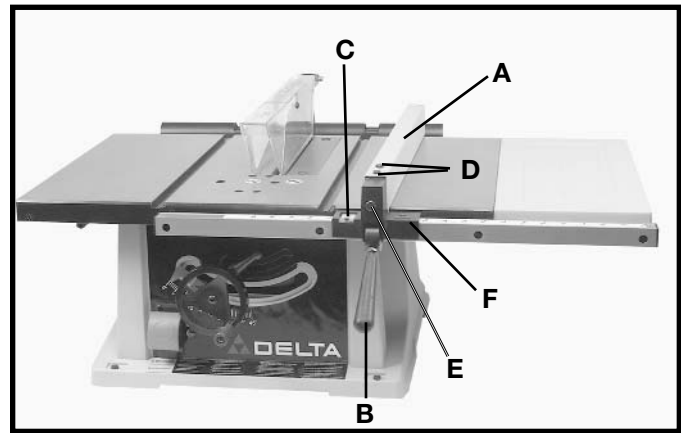

Fig.48

7. Loosen the two screws (D) Fig. 48, and lift up locking lever (B). Then while holding the fence bracket (F) firmly toward the front of the saw, move the rear end of the fence (A) until it is parallel with the miter gage slot. Then tighten two screws (D) and push down locking lever (B).
8. The clamping action of the fence (A) Fig. 48, can be adjusted by lifting up locking lever (B) and turning screw (E) clockwise to increase or counterclockwise to decrease the clamping action of the fence.

---

# MITER GAGE OPERATION AND ADJUSTMENTS

When straight cross-cutting (blade set 90 degrees to the table) the miter gage can be used in either table slot. When bevel cross-cutting (blade tilted) only use the miter gage in the right table slot where the blade is tilted away from the miter gage and your hands.

This miter gage is equipped with individually adjustable index stops at 90 degrees and 45 degrees right and left. Adjustment to the index stops can be made by loosening lock nuts (B) Fig. 49, and tightening or loosening the three adjusting screws (C) until they contact the other end of stop pin (D) when the miter gage is at 90 and 45 degrees to the saw blade. Then, tighten lock nuts (B).

To operate the miter gage, simply loosen lock knob (E) Fig. 49, and move the body of the miter gage to the desired angle. When the stop pin (D) is pushed in, the miter gage body will stop at 90 degrees and 45 degrees right and left. To rotate the miter gage body past these points, pull out stop pin (D).

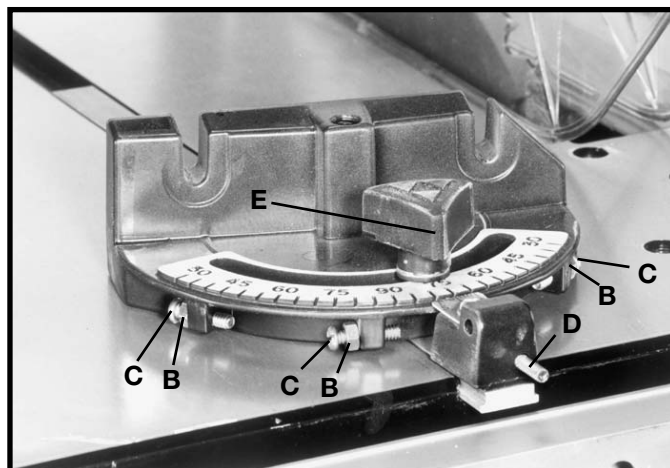

Fig.49



# ADJUSTING BLADE PARALLEL TO MITER GAGE SLOTS

The blade was adjusted parallel to the miter gage slots at the factory. In order to insure accurate cuts and help prevent kickback when cutting, this adjustment should be rechecked and if necessary, readjusted as follows:

1. **DISCONNECT MACHINE FROM POWER SOURCE.**
2. Raise the blade to its highest position and adjust the blade so it is 90 degrees to the table.
3. Select a tooth on the saw blade that is set to the left. Mark this tooth with a pencil or marker.
4. Using a combination square, place the body (A) Fig. 50, of the square against the miter gage slot and adjust the blade (B) of the square until it just touches the marked tooth, as shown.
5. Rotate the blade and check the same marked blade tooth at the rear of the saw table in the same manner, as shown in Fig. 51.

6. If the front and back measurements, shown in Figs. 50 and 51, are not identical, loosen four screws (C) Fig. 52. Carefully grasp and move the saw blade until the blade is parallel to the miter gage slot. Then tighten four screws (C) Fig. 52, securely. **NOTE:** If sufficient adjustment cannot be achieved by loosening screws (C), screws (D) may also be loosened if absolutely necessary to make the adjustment.

**NOTE: Guard has been removed for illustrative purposes only.**

## CHANGING THE BLADE

1. **DISCONNECT MACHINE FROM POWER SOURCE.**  
**⚠WARNING: USE ONLY 10" DIAMETER SAW BLADES RATED FOR 5000 RPM OR HIGHER WITH 5/8" ARBOR HOLES.**

2. Raise the saw blade to its maximum height and remove the table insert (A) Fig. 53.

3. Using the open end wrench (B) Fig. 53, place open end of wrench on flats on inside blade flange to keep the saw arbor from rotating and remove arbor nut (C) with wrench (D). Turn nut (C) counterclockwise to remove. Remove outside blade flange (E) and saw blade (F).

4. Assemble new blade, making certain teeth of blade are pointing down at the front of the saw table and assemble the outside blade flange (E) Fig. 53, and arbor nut (C). Tighten nut (C) with wrench (D) by turning nut clockwise while holding arbor steady with other wrench (B).

5. Replace table insert.

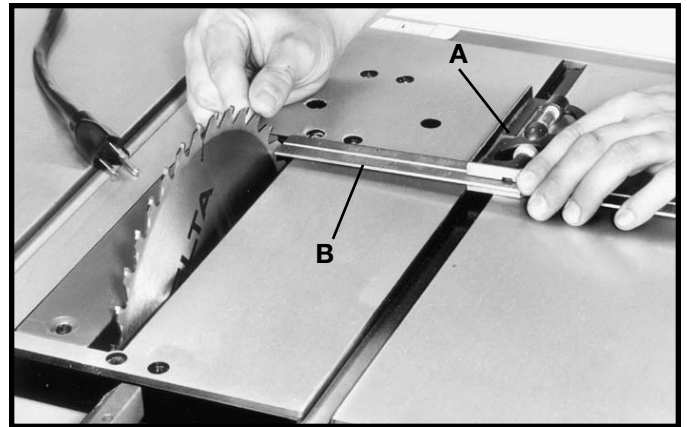

Fig. 50

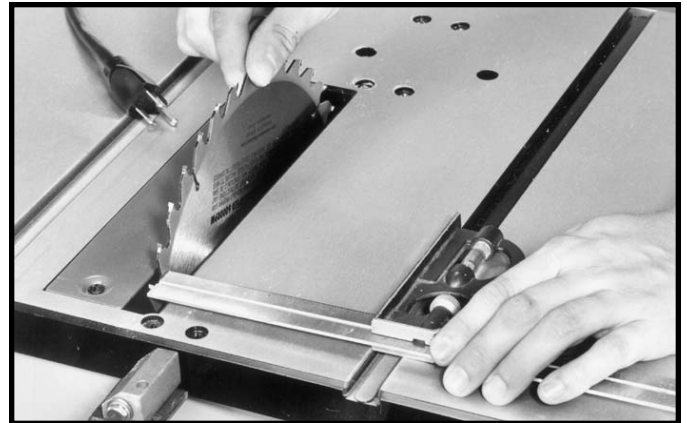

Fig. 51

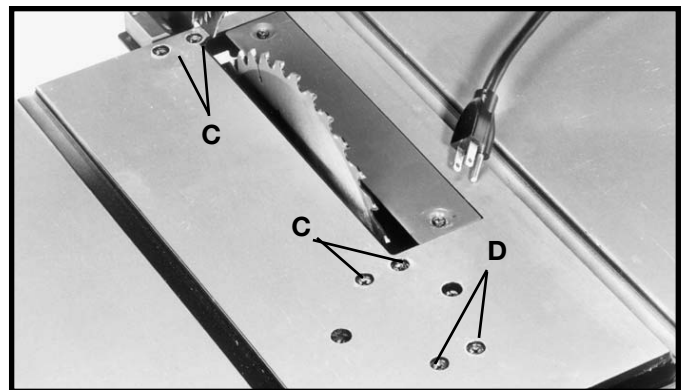

Fig. 52

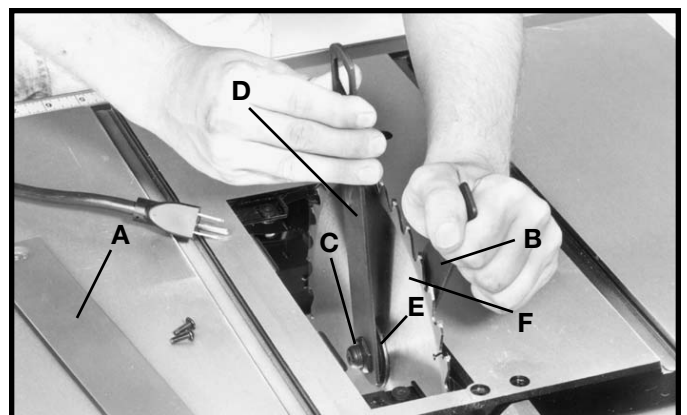

Fig. 53

# OPERATION

Common sawing operations include ripping and cross-cutting plus a few other standard operations of a fundamental nature. As with all power tools, there is a certain amount of hazard involved with the operation and use of the tool. Using the tool with the respect and caution demanded as far as safety precautions are concerned, will considerably lessen the possibility of personal injury. However, if normal safety precautions are overlooked or completely ignored, personal injury to the operator can result. The following information describes the safe and proper method for performing the most common sawing operations. Additional information on table saw operations can be obtained from the Delta "Getting the Most Out of Your Table Saw" How-To-Book, Catalog No. 11-400.

## CROSS-CUTTING

Cross-cutting requires the use of the miter gage to position and guide the work. Place the work against the miter gage and advance both the gage and work toward the saw blade, as shown in Fig. 54. The miter gage may be used in either table slot. When bevel cross-cutting (blade tilted) only use the miter gage in the right table slot where the blade is tilted away from the miter gage and your hands. **THE SAW GUARD MUST ALWAYS BE USED.**

Start the cut slowly and hold the work firmly against the miter gage and the table. One of the rules in running a saw is that you never hang onto or touch a free piece of work. Hold the supported piece, not the free piece that is cut off. The feed in cross-cutting continues until the work is cut in two, and the miter gage and work are pulled back to the starting point. Before pulling the work back it is good practice to give the work a little sideways shift to move the work slightly away from the saw blade. Never pick up any short length of free work from the table while the saw is running. Never touch a cut-off piece while the saw is running unless the piece is at least a one foot long.

**⚠WARNING: NEVER USE THE FENCE AS A CUT-OFF GAGE WHEN CROSS-CUTTING.**

For added safety and convenience the miter gage can be fitted with an auxiliary wood-facing. This auxiliary wood-facing can be fastened to the front of the miter gage by using two wood screws through the slots provided in the miter gage body and into the wood-facing.

## RIPPING

Ripping is the operation of making a length-wise cut through a board, as shown in Fig. 55, and the rip fence (A) is used to position and guide the work. One edge of the work rides against the rip fence while the flat side of the board rests on the table. Since the work is pushed along the fence, it must have a straight edge and make solid contact with the table. **THE SAW GUARD MUST ALWAYS BE USED.** The guard has anti-kickback fingers to prevent kickback and a splitter to prevent the saw kerf from closing and binding the blade.

Start the motor and advance the work, holding it down against the fence. Never stand in the line of the saw cut when ripping. Hold the work with both hands and push it along the fence and into the saw blade as shown in Fig. 55. After the workpiece is on the table the work can then be fed through the saw blade with one hand, as shown in Fig. 56. After the work is beyond the saw blade and anti-kickback fingers the feed can continue



Fig. 54

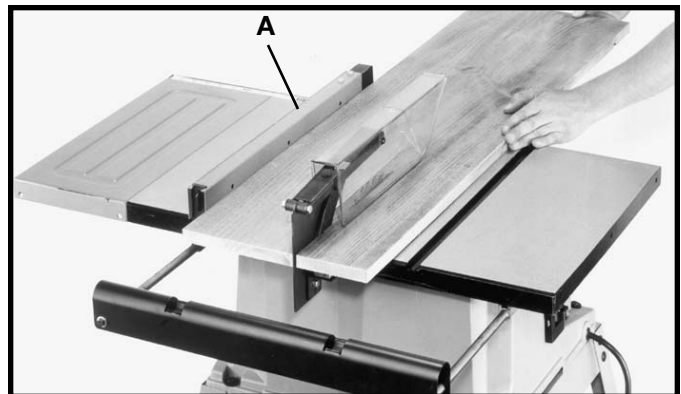

Fig. 55



Fig. 56

to the end of the table, after which the work is lifted and brought back along the outside edge of the fence. The cut-off stock remains on the table or tilts up slightly and is caught by the rear end of the guard or slides off the table to the floor. If the cut-off stock remains on the table it is not touched with the hands until the saw blade is stopped, unless it is a large piece allowing safe removal. When ripping boards longer than three feet, it is recommended that outfeed support (B) Fig. 56, should be extended as far out as possible to keep workpiece from falling off the saw table.



If the ripped work is less than 4 inches wide, a push stick should always be used to complete the feed, as shown in Fig. 124. The push stick can easily be made from scrap material as explained in the section “**CONSTRUCTING A PUSH STICK.**”

When ripping material under 2 inches in width, a flat pushboard is a valuable accessory since ordinary type sticks may interfere with the blade guard. That flat pushboard can be made as shown in Fig. 58.

### **USING AUXILIARY WOOD FACING ON RIP FENCE**

It is necessary when performing some special operations to add wood facing (A) Fig. 59, to one or both sides of the rip fence, as shown. The wood facing is attached to the fence with wood screws through the holes in the fence. 3/4 inch stock is suitable for most work although an occasional job may require 1 inch facing.

A wood facing should be used when ripping material such as thin paneling to prevent the material from catching between the bottom of the rip fence and the saw table surface.

Further information on the safe and proper operation of table saws is available in the Delta “Getting the Most Out of Your Table Saw” How-To-Book, Catalog No. 11-400. Additional information on table saw safety is also available by writing to:

**NATIONAL SAFETY COUNCIL**  
1121 Spring Lake Drive  
Itasca, IL 60143-3201

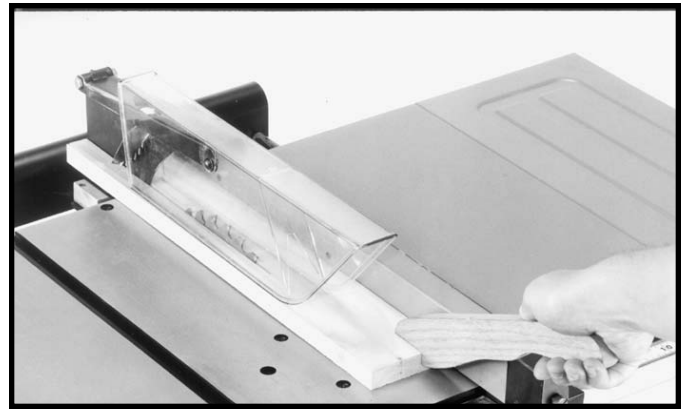

Fig. 57

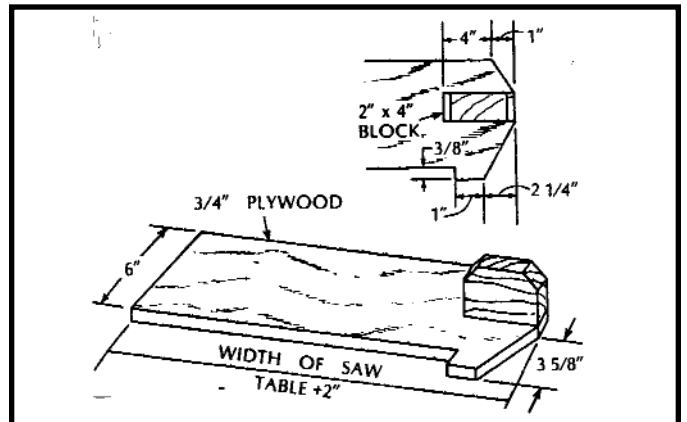

Fig. 58

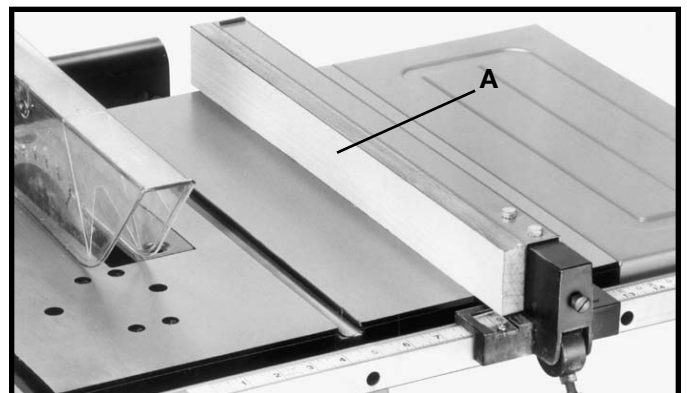

Fig. 59

# CONSTRUCTING A FEATHERBOARD

Fig. 60, illustrates dimensions for making a typical featherboard. The material which the featherboard is constructed of, should be a straight piece of wood that is free of knots and cracks. Featherboards are used to keep the work in contact with the fence and table and help prevent kickbacks. Clamp the featherboards to the fence and table so that the leading edge of the featherboards will support the workpiece until the cut is completed. Use featherboards for all non "thru-sawing" operations where the guard and spreader assembly must be removed (see Fig. 61). Always replace the guard and spreader assembly when the non thru-sawing operation is completed.

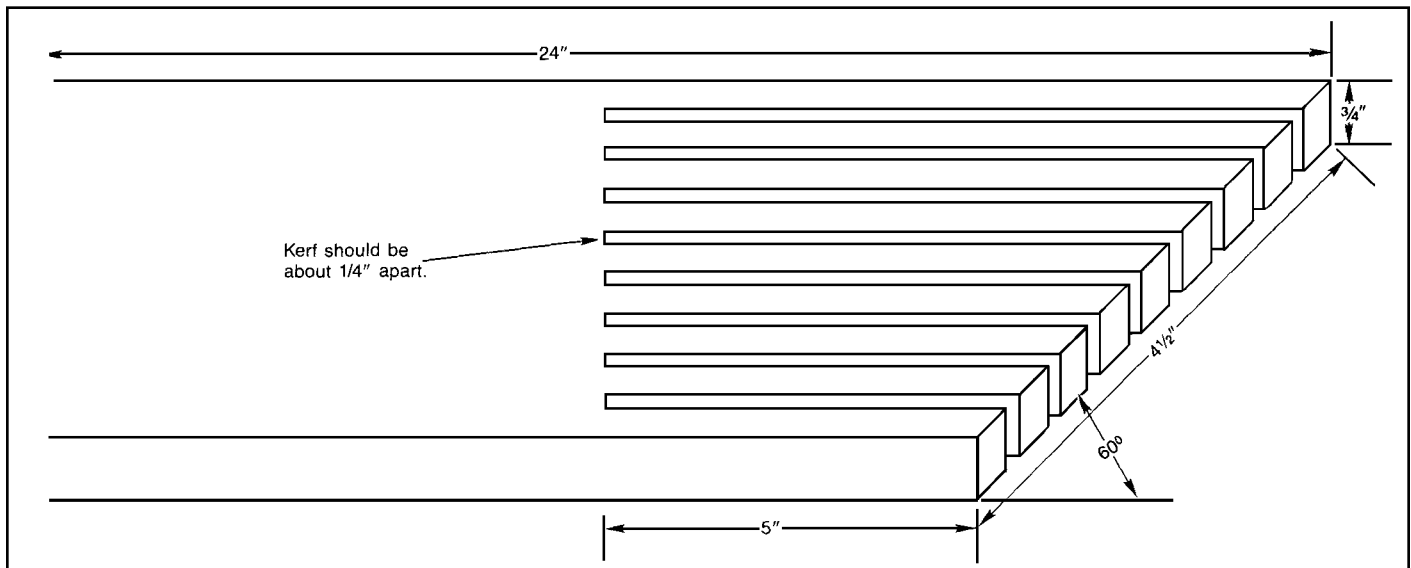

Fig. 60

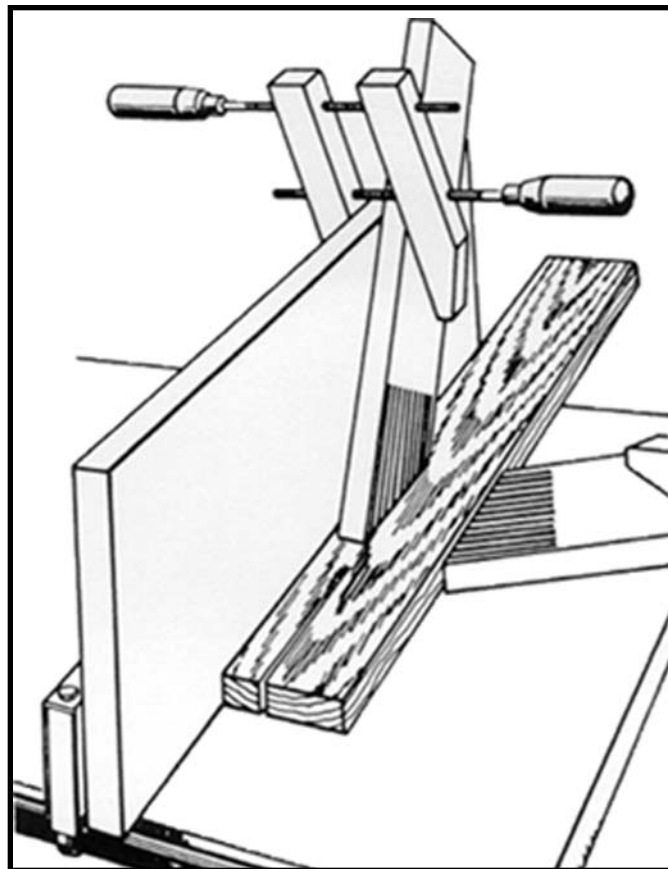

Fig. 61

## CONSTRUCTING A PUSH STICK

When ripping work less than 4 inches wide, a push stick should be used to complete the feed and could easily be made from scrap material by following the pattern shown in Fig. 62.

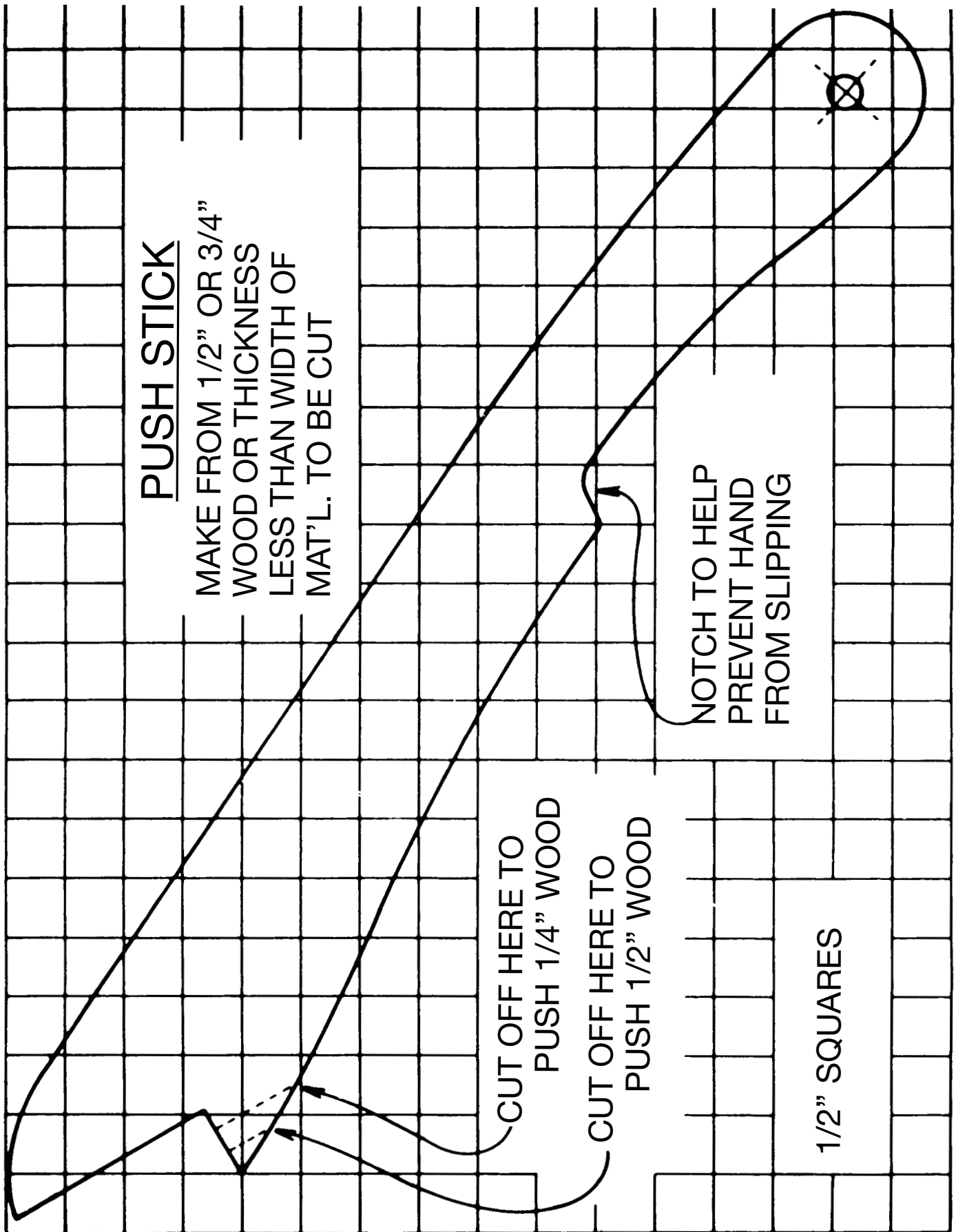



Fig. 62

# ACCESSORIES

A complete line of accessories is available from your Delta Supplier, Porter-Cable • Delta Factory Service Centers, and Delta Authorized Service Stations. Please visit our Web Site [www.deltamachinery.com](http://www.deltamachinery.com) for a catalog or for the name of your nearest supplier.

 **WARNING:** Since accessories other than those offered by Delta have not been tested with this product, use of such accessories could be hazardous. For safest operation, only Delta recommended accessories should be used with this product.



## PARTS, SERVICE OR WARRANTY ASSISTANCE

All Delta Machines and accessories are manufactured to high quality standards and are serviced by a network of Porter-Cable • Delta Factory Service Centers and Delta Authorized Service Stations. To obtain additional information regarding your Delta quality product or to obtain parts, service, warranty assistance, or the location of the nearest service outlet, please call 1-800-223-7278 (In Canada call 1-800-463-3582).



### Two Year Limited Warranty

Delta will repair or replace, at its expense and at its option, any Delta machine, machine part, or machine accessory which in normal use has proven to be defective in workmanship or material, provided that the customer returns the product prepaid to a Delta factory service center or authorized service station with proof of purchase of the product within two years and provides Delta with reasonable opportunity to verify the alleged defect by inspection. Delta may require that electric motors be returned prepaid to a motor manufacturer's authorized station for inspection and repair or replacement. Delta will not be responsible for any asserted defect which has resulted from normal wear, misuse, abuse or repair or alteration made or specifically authorized by anyone other than an authorized Delta service facility or representative. Under no circumstances will Delta be liable for incidental or consequential damages resulting from defective products. This warranty is Delta's sole warranty and sets forth the customer's exclusive remedy, with respect to defective products; all other warranties, express or implied, whether of merchantability, fitness for purpose, or otherwise, are expressly disclaimed by Delta.

Printed in U.S.A.

## Free Manuals Download Website

<http://myh66.com>

<http://usermanuals.us>

<http://www.somanuals.com>

<http://www.4manuals.cc>

<http://www.manual-lib.com>

<http://www.404manual.com>

<http://www.luxmanual.com>

<http://aubethermostatmanual.com>

Golf course search by state

<http://golfingnear.com>

Email search by domain

<http://emailbydomain.com>

Auto manuals search

<http://auto.somanuals.com>

TV manuals search

<http://tv.somanuals.com>