

250W
5 SPEED
DRILL PRESS

DP2
INSTRUCTION MANUAL



GMC
GLOBAL MACHINERY COMPANY

Contents

Warranty	2
Introduction	3
Environmental protection	3
Description of symbols	3
Specifications	3
Safety instructions	4
Additional safety rules for drill presses	5
Know your product	7
Accessories	8
Unpacking	8
Assembly	8
Adjusting the table height	10
Adjusting the table angle	10
Installing and removing drill bits	11
Setting the drilling depth	11
Changing the speed	11
Turning on and off	12
Operation	12
Maintenance and repair	13

Warranty Power Tools

Whilst every effort is made to ensure your complete satisfaction with this tool, occasionally, due to the mass manufacturing techniques, a tool may not live up to our required level of performance and you may need the assistance of our service department.

The product is warranted for a 2-year repair warranty for home domestic use from the date of original purchase. If found to be defective in materials or workmanship, the tool will be repaired free of charge.

A small freight charge may apply. Proof of purchase is essential. We reserve the right to reject any claim where the purchase cannot be verified.

This warranty does not include damage or defects to the tool caused by or resulting from abuse, accidents, alterations or commercial or business use. It also does not cover any bonus items or included accessories. Only the power tool is covered under this warranty.

With continuing product development, changes may have occurred which render the product received slightly different to that shown in this instruction manual.

Please ensure that you store your receipt in a safe place.

Conditions apply to the above warranty. For full details of the warranty terms and conditions please refer to our website – www.gmcompany.com

For prompt service we suggest you log your service request online - www.gmcservice.com.au, should you not have access to the internet, please contact our service department on 1300 880 001 (Australia) or 0800 445 721 (New Zealand).

Introduction

Your new GMC power tool will more than satisfy your expectations. It has been manufactured under stringent GMC Quality Standards to meet superior performance criteria.

You will find your new tool easy and safe to operate, and, with proper care, it will give you many years of dependable service.

CAUTION. Carefully read through this entire Instruction Manual before using your new GMC Power Tool. Take special care to heed the Cautions and Warnings.

Your GMC power tool has many features that will make your job faster and easier. Safety, performance, and dependability have been given top priority in the development of this tool, making it easy to maintain and operate.

Environmental protection



Recycle unwanted materials instead of disposing of them as waste. All tools, hoses and packaging should be sorted, taken to the local recycling centre and disposed of in an environmentally safe way.

Description of symbols

The rating plate on your tool may show symbols. These represent important information about the product or instructions on its use.



Wear hearing protection.
Wear eye protection.
Wear breathing protection.



N380

Conforms to relevant standards for electromagnetic compatibility.



Read and understand instruction manual before using this product

Specifications

Voltage:	230–240 V ~ 50 Hz
Motor:	250W (1/3HP) single phase
Chuck capacity:	13mm (1/2")
Spindle axis to column distance:	104mm
Max. spindle travel:	50mm
Max. spindle nose to table distance:	15mm
Max. spindle nose to base distance:	290mm
Range of spindle speeds:	500, 890, 1400, 1900, 2500/min
Overall dimensions H x W x D):	435mm x 220mm x 350mm
Net weight:	17kg

This tool is an earthed appliance.

Safety Instructions

WARNING. Read all instructions. Failure to follow all instructions listed below may result in electric shock, fire and/or serious personal injury. The term “power tool” in all of the warnings listed below refers to your mains-operated (corded) power tool or battery-operated (cordless) power tool.

General safety instructions

To use this tool properly, you must observe the safety regulations, the assembly instructions and the operating instructions to be found in this Manual. All persons who use and service the machine have to be acquainted with this Manual and must be informed about its potential hazards. Children and infirm people must not use this tool. Children should be supervised at all times if they are in the area in which the tool is being used. It is also imperative that you observe the accident prevention regulations in force in your area. The same applies for general rules of occupational health and safety.

WARNING. When using power tools, basic safety precautions should always be taken to reduce the risk of fire, electric shock and personal injury. Also, please read and heed the advice given in the additional important safety instructions.

- 1. Keep the work area clean and tidy.** Cluttered work areas and benches invite accidents and injury.
- 2. Consider the environment in which you are working.** Do not use power tools in damp or wet locations. Keep the work area well lit. Do not expose power tools to rain. Do not use power tools in the presence of flammable liquids or gases.
- 3. Keep visitors away from the work area.** All visitors and onlookers, especially children and infirm persons, should be kept well away from where you are working. Do not let others in the vicinity make contact with the tool or extension cord.
- 4. Store tools safely.** When not in use, tools should be locked up out of reach.

- 5. Do not force the tool.** The tool will do the job better and safer working at the rate for which it was designed.
- 6. Use the correct tool for the job.** Do not force small tools or attachments to do the job best handled by a heavier duty tool. Never use a tool for a purpose for which it was not intended.
- 7. Dress correctly.** Do not wear loose clothing or jewellery. They can be caught in moving parts. Rubber gloves and non-slip footwear are recommended when working outdoors. If you have long hair, wear a protective hair covering.
- 8. Use safety accessories.** Safety glasses and earmuffs should always be worn. A face or dust mask is also required if the sanding operation creates dust.
- 9. Do not abuse the power cord.** Never pull the cord to disconnect the tool from the power point. Keep the cord away from heat, oil and sharp edges.
- 10. Secure the work piece.** Use clamps or a vice to hold the work piece. It is safer than using your hand and frees both hands to operate the tool.
- 11. Do not overreach.** Keep your footing secure and balanced at all times.
- 12. Look after your tools.** Keep tools sharp and clean for better and safer performance. Follow the instructions regarding lubrication and accessory changes. Inspect tool cords periodically and, if damaged, have them repaired by an authorised service facility. Inspect extension cords periodically and replace them if damaged. Keep tool handles dry, clean and free from oil and grease.
- 13. Disconnect idle tools.** Switch off the power and disconnect the plug from the power point before servicing, when changing accessories and when the tool is not in use.
- 14. Remove adjusting keys and wrenches.** Check to see that keys and adjusting wrenches are removed from the tool before switching on.

15. Avoid unintentional starting. Always check that the switch is in the OFF position before plugging in the tool to the power supply. Do not carry a plugged in tool with your finger on the switch.

16. Use outdoor rated extension cords. When a tool is used outdoors, use only extension cords that are intended for outdoor use and are so marked.

17. Stay alert. Watch what you are doing. Use common sense. Do not operate a power tool when you are tired.

18. Check for damaged parts. Before using a tool, check that there are no damaged parts. If a part is slightly damaged, carefully determine if it will operate properly and perform its intended function. Check for alignment of moving parts, binding of moving parts, breakage of parts, proper mounting and any other conditions that may affect the operation of the tool. A part that is damaged should be properly repaired or replaced by an authorised service facility, unless otherwise indicated in this Instruction Manual.

Defective switches must be replaced by an authorised service facility. Do not use a tool if the switch does not turn the tool on and off correctly.

19. Guard against electric shock. Prevent body contact with grounded objects such as water pipes, radiators, cookers and refrigerator enclosures.

20. Use only approved parts. When servicing, use only identical replacement parts. Use an authorised service facility to fit replacement parts.

Additional safety rules for drill presses

WARNING. For your own safety, do not try to use your drill press or plug it in until it is completely assembled and installed according to the instructions and until you have read and understood the following:

1. Your drill press must be bolted securely to a workbench. In addition, if there is any tendency for your drill press to move during certain operations, bolt the workbench to the floor.

2. This drill press is intended for use in dry conditions and indoor use only.
3. Always wear safety goggles which comply to a recognised standard. Use a face or dust mask along with safety goggles if the drilling operation is dusty. Use ear protectors, especially during extended periods of operation.
4. Do not try to drill material too small to be securely held. Do not drill material that does not have a flat surface unless it is clamped securely.
5. Always keep hands out of the path of the drill bit. Avoid awkward hand positions where a sudden slip could cause your hand to move into the drill bit.
6. Do not install or use any drill bit that exceeds 175mm (7 inches) in length or extends more than 150mm (6 inches) below the chuck jaws. They can suddenly bend outwards or break.
7. Do not use wire wheels, router bits, shaper cutters, circle (fly) cutters or rotary planers on this drill press.
8. When cutting a large piece of material make sure it is fully supported at the table height.
9. Do not perform any operation freehand. Always hold the workpiece firmly against the table so it will not rock or twist. Use clamps or a vice for unstable workpieces.
10. Make sure there are no nails or foreign objects in the part of the workpiece to be drilled.
11. Whenever possible, position the workpiece to contact the left side of the column; if it is too short or the table is tilted, clamp solidly to the table.
12. If the workpiece overhangs the table such that it will fall or tip if not held, clamp it to the table or provide auxiliary support.
13. Set the drill press to a speed appropriate to the job.
14. Do not start the drill press while the drill bit is touching the workpiece.
15. When using a drill press vice, always fasten it to the table.

16. Make sure all clamps and locks are firmly tightened before drilling.
17. Securely lock the head and table support to the column, and the table to the table support before operating your drill press.
18. Never turn your drill press on before clearing the table of all objects (tools, scraps of wood etc.)
19. Before starting the operation, jog the motor switch to make sure the drill bit does not wobble or vibrate.
20. Let the spindle reach full speed before starting to drill. If your drill press makes an unfamiliar noise or if it vibrated excessively, stop immediately, turn the drill press off and unplug it. Do not restart until the problem is corrected.
21. Do not perform layout assembly or setup work on the table while the drill press is in operation.
22. Do not exceed the rpm stated on the bit or accessory. See the instructions that come with the accessory.
23. When drilling large diameter holes, clamp the workpiece firmly to the table. Otherwise, the bit may grab and spin the workpiece at high speed. Do not use fly cutters or multiple-part cutters, as they can come apart or become unbalanced in use.
24. Make sure the spindle has come to a complete stop before touching the workpiece.
25. To avoid injury from accidental starting, always turn the switch off and unplug the drill press before installing or removing any accessory attachment or making any adjustment.

CAUTION! Do not expose to rain or use in damp locations.

WARNING! For your own safety read instruction manual before operating drill press. Wear eye protection, do not wear gloves, necktie or loose clothing, clamp workpiece or brace against column to prevent rotation, use recommended speed for drill accessory and workpiece material.

Know your product

Before using the drill press, familiarise yourself with all the operating features and safety requirements.

Use the tool only for the applications intended. All other applications are expressly ruled out.

1. Pulley cover
2. Belt tension lock knob
3. Head lock set screw
4. Feed handle x 3
5. Column
6. Column support
7. Column support bolts x 3
8. Base
9. Support lock
10. Table assembly
11. Chuck
12. Depth scale
13. Head assembly
14. ON/OFF Switch
15. Collar stop
16. Collar screw
17. Collar nut
18. Hex key
19. Feed wheel hub
20. Depth scale nut
21. Pulley cover knob
22. Quill
23. Chuck key

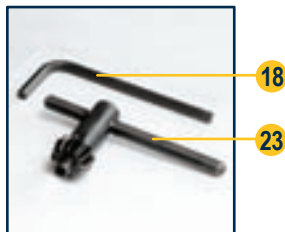
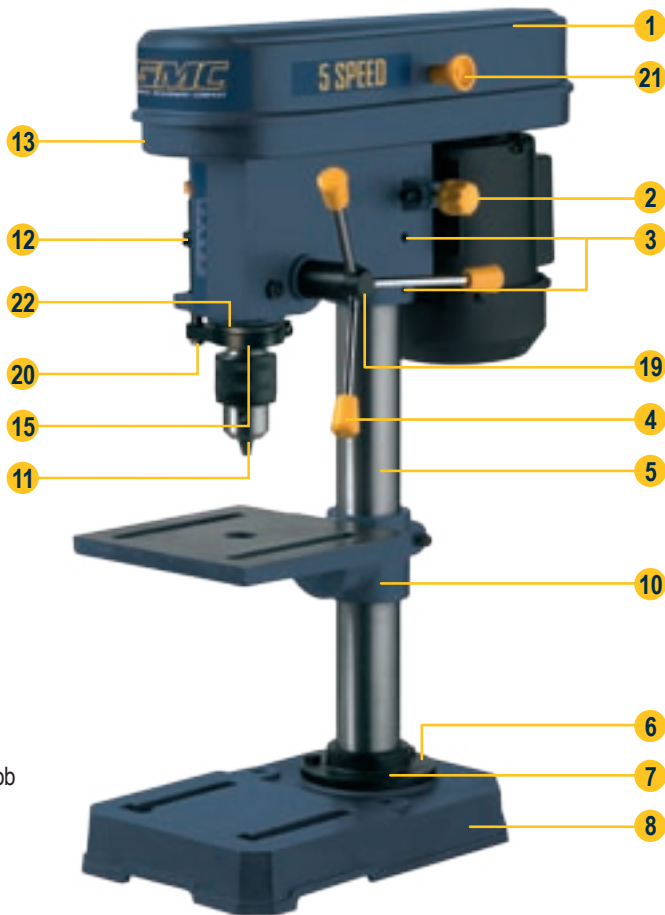

Accessories

The tool is supplied with the following accessories:

- 4mm Hex key
- Chuck Key

Unpacking

Carefully remove all parts from the packaging and check that they are in good condition.

Check that the following parts are supplied.

Bags of fittings comprising:

- 4mm hex key
- Belt tension lock knob
- Support lock
- 3 x 8mm x 20mm bolts
- 3 x feed handles
- Keyed chuck
- Chuck key
- Collar stop
- Collar screw
- Collar nut

We recommend that you purchase your accessories in the store from where you purchased the tool. Use good quality accessories and the brand recommended by the vendor.

Assembly

The following tools are required to assemble the drill press

- 4mm hex key (supplied)
- Wrench (not supplied)
- Phillips head screwdriver (not supplied)



Assembly time

The DP2 drill press will take approximately 15 minutes to assemble.

IMPORTANT. If any parts are missing, please contact the place of purchase. DO NOT attempt to operate the machine until the missing parts are available.

WARNING. Ensure the machine is disconnected from the mains plug at all times during assembly and maintenance.

Place the base (8) on a flat surface.

Place the column support (6) on base and align the 3 holes in the column support with the holes in the base (8).

Using the 3 x 8mm diameter x 20mm long column support bolts secure the column support to the base and tighten with a wrench (not supplied).

Slide the table assembly (10) onto the column (5).



Install the support lock (9) handle, from the right side into the rear of the table support (10) and tighten by hand. Once tightened, ensure the table is fixed and cannot move.

Lift the head assembly (13) and slide it onto the column assembly (5) as far as possible.



Align the head assembly with the table assembly (10) and base (8). Using the hex key (18) tighten the head lock set screw (3) into the head assembly. This will secure the head onto the column.

Screw the feed handles (4) into the threaded holes of the feed wheel hub (19) and tighten.

Clean the spindle nose of the chuck (11) with a clean cloth. Push the chuck up into the spindle nose as far as possible. Lightly tap the nose of the chuck with a piece of wood to ensure proper fitting of the chuck on the spindle lock.

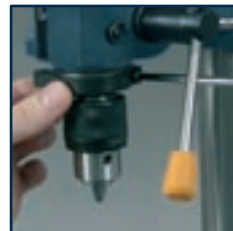
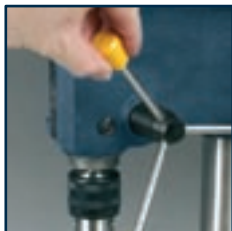

Fit the collar stop (15) over the quill (22). Place the collar nut (17) into the designated position of the collar stop and in the other of side of the collar stop feed the collar screw (16) in and tighten into the collar nut.

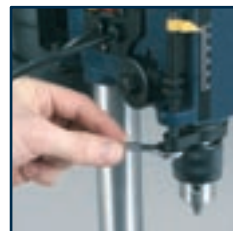

Insert the depth scale (12) into the depth collar stop (15) and fit into the depth collar and place the depth scale nut (20) onto the end of the depth scale.

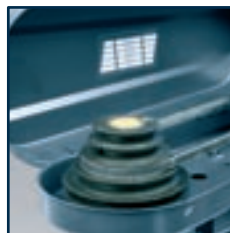

	2500 RPM	
	1900 RPM	
	1400 RPM	
	890 RPM	
	500 RPM	

Open the pulley cover to discover the motor speed pulleys and belt. Refer to the inside of the pulley cover for speed reference.

Note. When fitting belts it is easier to place the belt onto the small pulley and then turn it onto the larger pulley.

Unscrew the screw from the pulley cover knob (21) and place it through the hole on the right side of the pulley cover (1) and tighten.

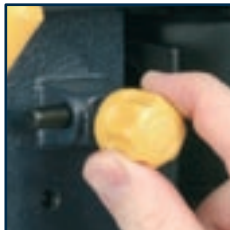

To apply tension to the belt, loosen the belt tension lock knob (2) and push the motor housing backwards. Tighten belt tension lock knob.

Replace and secure the pulley cover.

Adjusting the table height

CAUTION. Always ensure that the drill press is switched off and the plug is removed from the power point before making any adjustments.

Loosen the support lock (9).



Rotate the handle in an anti-clockwise direction to loosen the table support (10).

Raise/Lower the table support to the desired height.

Tighten the support lock to secure the table.



Adjusting the table angle

CAUTION. Always ensure that the drill press is switched off and the plug is removed from the power point before making any adjustments.

Loosen the screw under the table by rotating it in an anti-clockwise direction.

Tilt the table to the desired angle as indicated on the bevel scale.

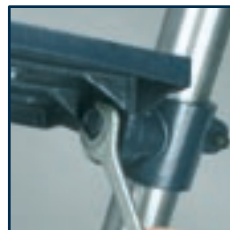

Tighten the screw under the table by rotating it in a clockwise direction.

Note. When the table is tilted the work piece should be clamped to the table.

Installing and removing drill bits

CAUTION. Always ensure that the drill press is switched off and the plug is removed from the power point before making any adjustments.

Using the chuck key loosen the chuck (11) so that the jaws are open wide enough to allow a bit to be inserted. The chuck is loosened by rotating the collar in an anti-clockwise direction.



Place the bit into the open chuck as far as it will go. Tighten the chuck by rotating it with the use of the chuck key in a clockwise direction.

To remove the bit, loosen the chuck by rotating the collar in an anti-clockwise direction.

Setting the drilling depth

CAUTION. Always ensure that the drill press is switched off and the plug is removed from the power point before making any adjustments.

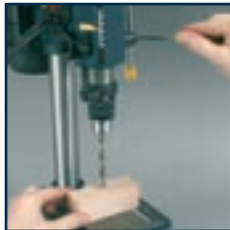

To change the maximum permitted depth of travel, first loosen the depth scale nut (20).

Rotate the feed wheel (4) to the desired depth on the depth scale (12).

Ensuring the drill bit is tight in the chuck use the feed wheel to lower the spindle until the drill bit just touches the work piece.

Changing the speed

CAUTION. Always ensure that the drill press is switched off and the plug is removed from the power point before making any adjustments.

The speed of the drill press is determined by the size of the pulley steps that the belt is attached to. Using a smaller pulley step on the front pulley means a faster drill speed; using a larger pulley step on the front pulley means a slower drill speed. The table indicates the speed of the drill in the various belt positions.

Remove the plug from the mains socket.

	2500 RPM	
	1900 RPM	
	1400 RPM	
	890 RPM	
	500 RPM	

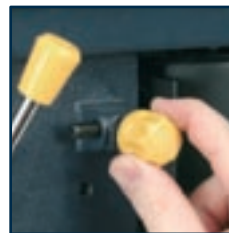

Lift up the pulley cover (1).

Loosen belt tension lock knob (2).

Move the belt to the correct pulley step for the desired speed.

Push motor backward until moderate belt tension is acquired. Tighten the belt tension lock knob.

Note. The belt should push down no more than 13mm.

To select a faster drill speed, move the belt up to a higher step on the front and central pulleys and lower step on the central and rear pulleys. Rotating the pulleys and “rolling” the belt onto the larger pulley will make this easier.

To select a slower drill speed, move the belt down to a smaller step on the front and central pulleys and a higher step on the central and rear pulleys. Rotating the pulleys and “rolling” the belt onto the larger pulley will make this easier.

To tighten the belts on the pulleys pull the motor backwards. This is best done by grabbing hold of the top of the rear pulley and the bottom of the motor housing.

Rotate the pulley by hand to ensure everything is aligned and correct.

Tighten the belt tension lock knob.

Replace the pulley cover.

Turning on and off

To start the drill press insert the switch disabling insert and move the switch up to the ‘ON’ position.

Move the ON/OFF switch (14) down to the ‘OFF’ position to turn the drill press off.

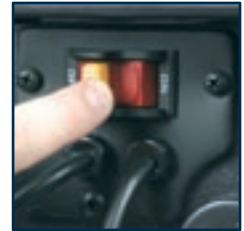
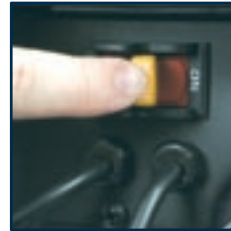

Remove the switch disabling insert to prevent unauthorised use and store it in a secure location out of reach of children.

CAUTION. Always ensure that the drill press is switched off and the plug is removed from the power point before making any adjustments.

CAUTION. For through drilling always ensure that the hole in the centre of the table is aligned with the drill bit.

WARNING. On start-up overtightening the belts may prevent the drill press from starting.

WARNING. Don't force the drill, allow the drill bit to do the work.

Operation

Adjust the table height, table angle, drilling depth and speed as required for the application.

Insert the drill bit required for the application.

Mark the drilling points on the work piece.

Where possible secure the workpiece in position with vice or clamps.

Turn on the drill press using the on/off switch.

Rotate the feed wheel to bring the drill bit down to the workpiece.

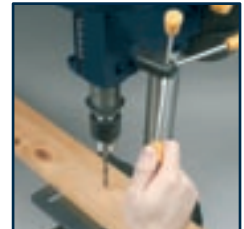

Apply pressure to the feed wheel and slowly drill through the workpiece. Don't force the drill, allow the drill bit to do the work.

After drilling the hole release the feed wheel and allow the spindle to return to its original position.

Turn off the drill press.

Wood drilling

- For maximum performance, use high speed steel bits for wood drilling.
- Secure the workpiece to prevent it from turning when drilling.
- When drilling through holes, place a block of wood behind the workpiece to prevent ragged or splintered edges on the back side of the hole.

Metal drilling

- For maximum performance, use high speed steel bits for metal or steel drilling.
- Use a centre punch to mark the hole location on the workpiece.
- Maintain a speed and pressure which allows cutting without overheating the bit. Applying too much pressure will:
 - Overheat the drill
 - Wear the bearings
 - Bend or burn bits
 - Produce off-centre or irregular shaped holes
- When drilling large holes in metal it is recommended to drill with a small bit at first, then finish with a larger bit. Also, lubricate the bit with oil to improve drilling action and increase bit life.

Maintenance and repair

Repairs

Only an authorised service centre should replace the cordset or effect other repairs. If the cordset is damaged or worn, have it repaired or replaced by an authorised service centre.

Maintenance

WARNING. Always ensure that the tool is switched off and the plug is removed from the power point before making and adjustments or maintenance procedures.

Cleaning

Keep the tool's air vents unclogged and clean at all times.

Remove dust and dirt regularly. Cleaning is best done with a soft brush or a rag.

Re-lubricate all moving parts at regular intervals.

Never use caustic agents to clean plastic parts.

CAUTION. Do not use cleaning agents to clean the plastic parts of the tool. A mild detergent on a damp cloth is recommended.

General inspection

Regularly check that all the fixing screws are tight. They may vibrate loose over time.

If the supply cord needs replacing, the task must be carried out by the manufacturer, the manufacturer's agent, or an authorised service centre in order to avoid a safety hazard.



Attach Your
Receipt Here

GMC customer assist

If your product needs repairing or you simply need help or advice, please contact us on our Customer Assist Line 1300 880 001 (Australia) or 0800 445 721 (New Zealand).

For prompt service we suggest you log your service request online at www.gmcservice.com.au. Should you not have access to the Internet, please contact our service department on 1300 880 001 (Australia) or 0800 445 721 (New Zealand). 7am – 7pm, 7days a week (AEST).

Please note that if repair is required, you must provide a valid original purchase receipt.

You will need the following details at hand to log your service request;

Personal details: First & Last name, address, pick up address, contact phone numbers, email address

Product details: Product number, date of purchase, retailer bought from, State & postcode, receipt number, reason for the request, copy of official purchase receipt

Attach your purchase receipt and save with this Manual for future reference.

Please refer to our website www.gmcompany.com for full GMC warranty Terms and Conditions.

The GMC logo is rendered in a bold, blue, italicized sans-serif font. The letters are thick and have a slight 3D effect. A registered trademark symbol (®) is located at the bottom right of the 'C'.

GLOBAL MACHINERY COMPANY

Download from www.Somanuals.com. All Manuals Search And Download.

Free Manuals Download Website

<http://myh66.com>

<http://usermanuals.us>

<http://www.somanuals.com>

<http://www.4manuals.cc>

<http://www.manual-lib.com>

<http://www.404manual.com>

<http://www.luxmanual.com>

<http://aubethermostatmanual.com>

Golf course search by state

<http://golfingnear.com>

Email search by domain

<http://emailbydomain.com>

Auto manuals search

<http://auto.somanuals.com>

TV manuals search

<http://tv.somanuals.com>