

MOTORISED WOOD TURNING LATHE OWNER'S MANUAL

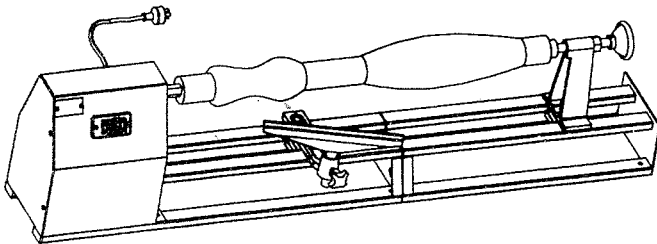

CONGRATULATIONS

You have just purchased one of our growing family of Bench Power Tools. Each is engineered and manufactured to the highest standards of quality. You will find your new Wood Turning Lathe a very useful tool. It will perform between centre turning and faceplate turning, and is especially suited to high speed sanding and polishing of finished work.

This Wood Turning Lathe is a self-contained power tool not requiring the purchase of a seperater motor.

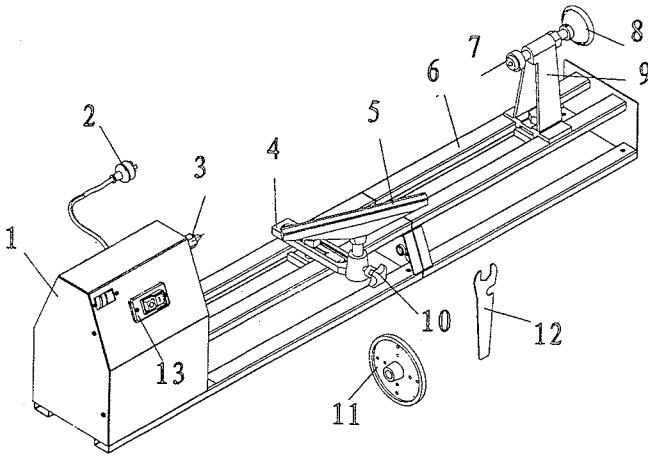

MAIN FEATURES

- | | |
|-----------------------|--------------------|
| 1. HEAD | 8. HAND WHEEL |
| 2. CABLE | 9. TAIL STOCK |
| 3. DRIVE CENTER | 10. LOCKING HANDLE |
| 4. TOOL RESTHOLDER | 11. FACE PLATE |
| 5. TOOL REST | 12. WRENCH |
| 6. REAR PART-BED RAIL | 13. SWITCH |
| 7. LIVE CENTER | |

SAFETY RULES FOR ALL POWER TOOLS

1. **READ AND BECOME FAMILIAR**
With the entire operating manual.
2. **KEEP GUARDS AND COVER**
In place and in working order.
3. **ALWAYS USE SAFETY GLASSES.**
Also use face or dust mask if cutting operations is dusty. Everyday eyeglasses only have impact resistant lenses. They are not safety glasses.
4. **KEEP WORK AREA CLEAN.**
Cluttered areas and benches invite accidents.
5. **DON'T FORCE TOOL.**
It will do a better and safer job at the rate for which was designed.
6. **AVOID ACCIDENTAL STARTING.**
Make sure switch is in "OFF" position before plugging in.
7. **DISCONNECT TOOLS BEFORE SERVICING** and when changing accessories such as spindle, centre, chuck etc.
8. **DON'T OVER REACH.**
Keep your proper footing and balance at all times. For best footing wear rubber soled footwear. Keep floor clear of oil, scrap wood, etc.
9. **WEAR PROPER APPRAEL.**
Loose clothing or jewelry may get caught in moving parts. Wear protective hair covering to contain long hair.
10. **MAKE WORKSHOP KIDPROOF.**
Place a padlock on the switch when the machine is not in use and store the key in a safe location.
11. **REMOVE ADJUSTING KEYS AND WRENCHES.**
Form habit of checking to see that keys and adjusting wrenches are removed from tool before turning it on.
12. **AVOID DANGEROUS ENVIRONMENT.**
Don't use power tools in damp or wet locations. Keep your work area well illuminated. DO NOT USE in explosive atmosphere (around paint, flammable liquids, etc).
13. **KEEP CHILDREN AWAY.**
All visitors should be kept a safe distance from work area, especially while operation unit.
14. **USE THE PROPER TOOL.**
Don't force tool or attachment to do a job for which it was not designed.
15. **MAINTAIN TOOLS IN TOP CONDITION.**
Keep tools sharp and clean for best and safest performance. Follow instructions for lubricating and changing accessories.
16. **SECURE WORK.**
Use clamps or a vise to hold work when practical. It's safer than using your hand and prevents round or irregularly shaped pieces from turning.
17. **CHECK DAMAGED PARTS.**
Before further use of the tool, a guard or other part that is damaged should be checked to assure that it will operate properly and perform its intended function - check for alignment of moving parts, breakage of parts, mounting, any other conditions that may affect its operations. A guard or other part that is damaged should be properly repaired or replaced.
18. **USE RECOMMENDED ACCESSORIES** - Consult Owner's Manual. Use of improper accessories could be hazardous.
19. **NEVER STAND ON TOOL.**
Injury could occur from a fall.
20. **NEVER LEAVE TOOL RUNNING AND UNATTENDED.**
21. **ALWAYS REMOVE CORD PLUG** from electrical outlet when adjusting, changing parts or working on tool.

BED RAIL CONNECTION

As per instruction showed in Fig.1,connecting the two part bed rails.

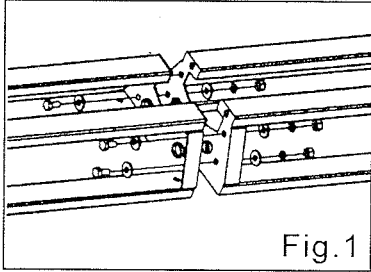

Fig.1

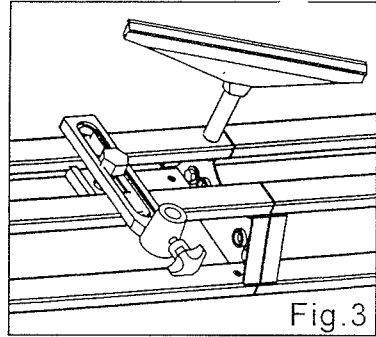

Fig.3

TOOL REST HOLDER ASSEMBLY

Put the tool rest holder properly on the bed rail, and fasten it with guide track plate by screw. See Fig.2

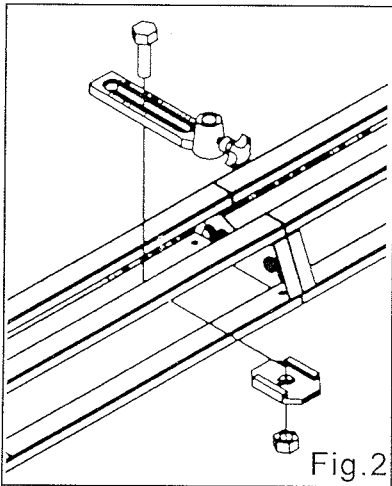

Fig.2

TAIL STOCK ASSEMBLY

Assemble the tail stock as per Fig.4

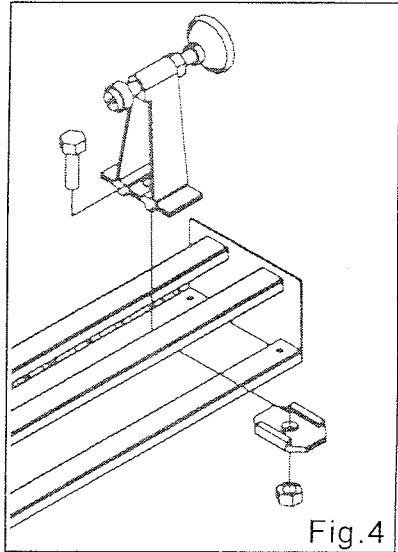

Fig.4

TOOL REST ASSEMBLY

Insert the tool rest into the holder and lock it with locking handle, See Fig.3

INSTALLATION

The wood lathe should be bolted to a solidly built work bench. Mounting holes are provided in the base at both the headstock and tailstock end of the lathe. Large flat washers should be used between the bolt heads and the housing to fasten the wood lathe more

securely and prevent damage. Tighten snugly but do not overtighten. Fig.5

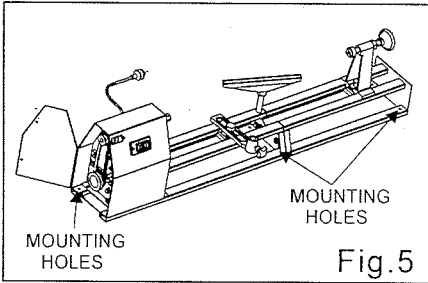

CHANGING SPEEDS

1. Turn the power off at the main switch.
2. Loosen motor mounting bolts under pulley cover.
3. Change belt to the desired pulley steps.
4. Lift belt tension lever to tighten belt.
5. Retighten motor mounting bolts.

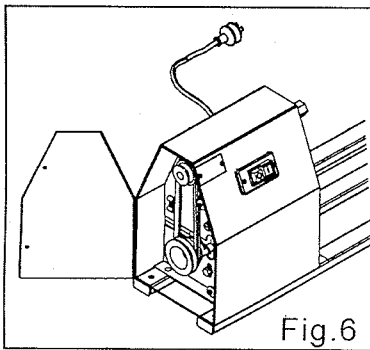

CHANGING FACEPLATE AND DRIVE CENTRE

The adjustment spanner has jaws which fit across flats on the headstock spindle. Locate the spanner across the flats and unscrew the faceplate or drive centre towards you. See Fig.7

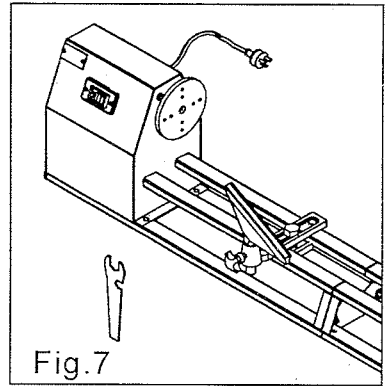

MOVING TAILSTOCK AND TOOLREST

The tailstock and toolrest are held to the bed with lock nuts underneath the bed rails. To move them to a new position, loosen the nut with the adjustment spanner, slide the tailstock or toolrest along the bed and retighten the nut. The toolrest is held in place by the lockknob. See Fig.8

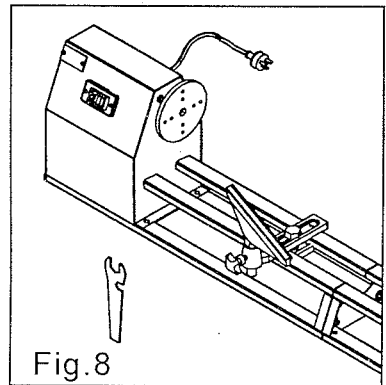

MOTOR

An Induction type motor is provided with the lathe. The rear cover of the lathe has ventilation slots to provide additional air movement over the motor.

The rear cover can be removed by simply undoing four screws to inspect the motor when needed. Always keep motor ventilations slots clear, cleaning woodchips frequently. See Fig.9

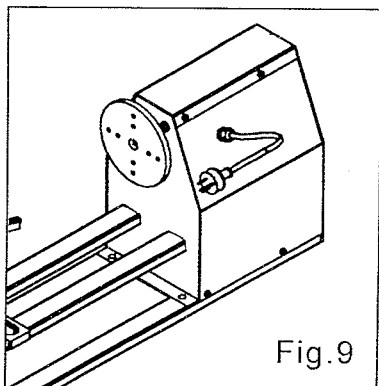

Fig.9

After using your chisels maintain their fine cutting edge with an oilstone, taking care to keep the original angles. Or use a professional sharpening tool with a holder to set angles, a fine grinding wheel for resharping and a stropping wheel or polishing th cutting edge. See Fig11

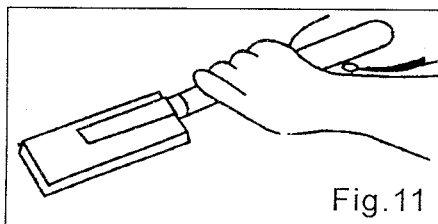

Fig.11

CHISELS FOR WOODTURNING

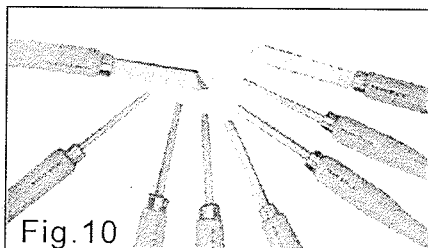

Fig.10

- | | |
|-----------------|-----------------|
| 1. Large skew | 5. Small gouge |
| 2. Medium skew | 6. Round nose |
| 3. Large gouge | 7. Spearpoint |
| 4. Medium gouge | 8. Parting tool |

Successful woodturners invest in good quality chisels and keep them well maintained. Figure 7 shows a typical 8 piece chisel set which will cover most of your needs. Use the gouges for roughing in round nose for shaping, skewers for planing and fine line detailing, spear point for V grooves, and the parting tool for cutting off finished work.

TURNING BETWEEN CENTRES

Turning between centres is the operation of turning a long workpiece supported at one end by the driving centre, and by the tail stock centre at the other.

MARKING THE CENTRES-Draw two diagonal lines across each end of the workpiece, from corner to corner, The junction of the lines will be the correct centre, Mark the centres with an awl or a drill. See Fig.12

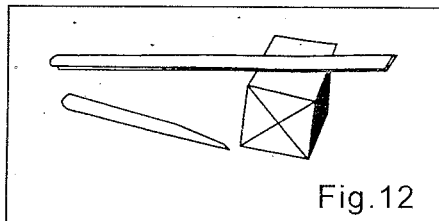

Fig.12

REMOVING WASTE STOCK-With a jack plane or bandsaw remove the four corners of the timber along its length to form an octagonal workpiece. This speeds the operation of turning down to round. See Fig. 13

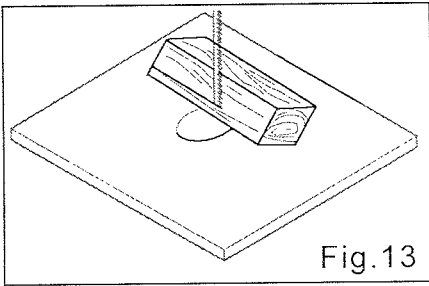

Fig.13

MOUNTING THE WORK BETWEEN CENTRES-Unscrew driving centre from the lathe spindle. Locate the point of the driving centre in the hole marked at one end of the timber, and hammer home with a wooden mallet of soft hammer. See Fig.14

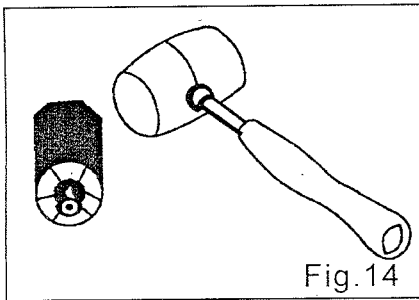

Fig.14

Screw the timber and driving centre onto the headstock spindle, and move the tailstock up to the opposite end of the timber, locating the tailstock spindle in the centre hole marked previously.

Tighten the tail stock lock nut underneath the bed rails Turn the tailstock spindle until the work is held firmly but still rotates freely. Tighten the spindle lock nut.

POSITIONING TOOL REST-The position of the chisel and operator comfort is more important than the actual height of the tool rest. Set it at centre height to begin with, and adjust it slightly higher or lower after trial to suit the operation. See Fig. 15

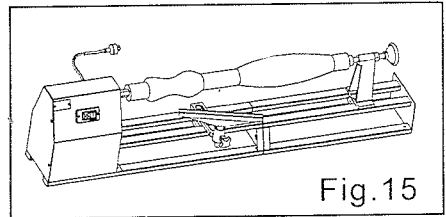

Fig.15

Always rotate the work one full turn before switching on the motor to be sure that the timber is free of all obstructions.

FACEPLATE TURNING

Faceplate turning is the operation of turning a large workpiece supported by the faceplate only.

MAKING A BACKING PIECE-Use a piece of 1"(25mm) thick timber larger than the diameter of the faceplate.

Screw the backing piece to the faceplate using woodscrews through the holes in the back of the faceplate. Mount the faceplate and backing piece onto the lathe spindle and carefully turn the timber until it is completely circular and slightly larger in diameter than the faceplate. See Fig.16

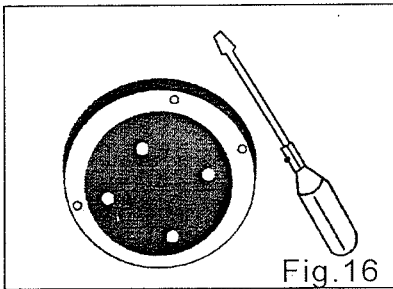

The backing piece provides a surface on which to mount the workpiece and is also a protective spacer between your chisels and the metal faceplate

MOUNTING WORK TO THE BACKING

PIECE-Spread wood-working adhesive over the packing piece. Place brown paper over the adhesive and apply adhesive to the outside of the paper. Spread adhesive on the workpiece, press the workpiece against the brown paper. Allow the adhesive to dry completely, Clamping may be required, Follow the adhesive manufacturer's instructions carefully.

When turning is completed the finished article can be easily pried off the face plate with a flat chisel.

Work can also be screwed directly to the faceplate by drilling from the holes in the back of the faceplate completely through the backing piece. Make sure that enough material is allowed so that the chisel will not hit a screw during the turning operation. Excess timber can be cut off with a handsaw or fret saw when turning is completed.

TURNING THE TIMBER TURNING BETWEEN CENTRES-

Use a gouge or round nose chisel to rough the timber to the desired shape. Hold the chisel firmly against the tool rest. Use the hand holding the handle of the chisel to raise or lower the cutting point, with the tool rest as a fulcrum.

When the rough shape is ready use other chisels for final shaping and decorative grooving as required. See Fig17

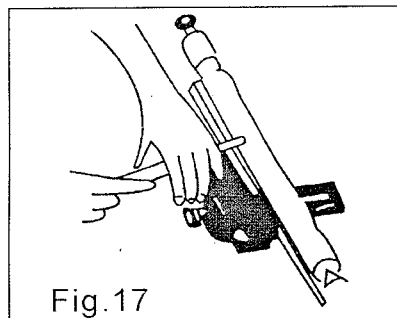

FACEPLATE TURNING-Mount the faceplate and workpiece to the lathe spindle. Start by turning the outside of the work first. Whenever possible bring the tailstock up to support the workpiece.

Move the tailstock well clear when turning the inside of the work. Extra care must be taken that the chisel does not catch on the work, particularly when the inside turning is long and narrow. See Fig.18

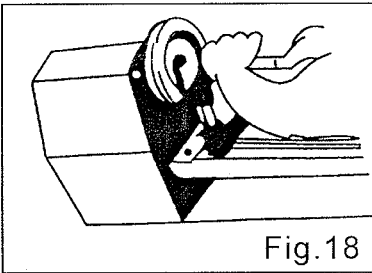
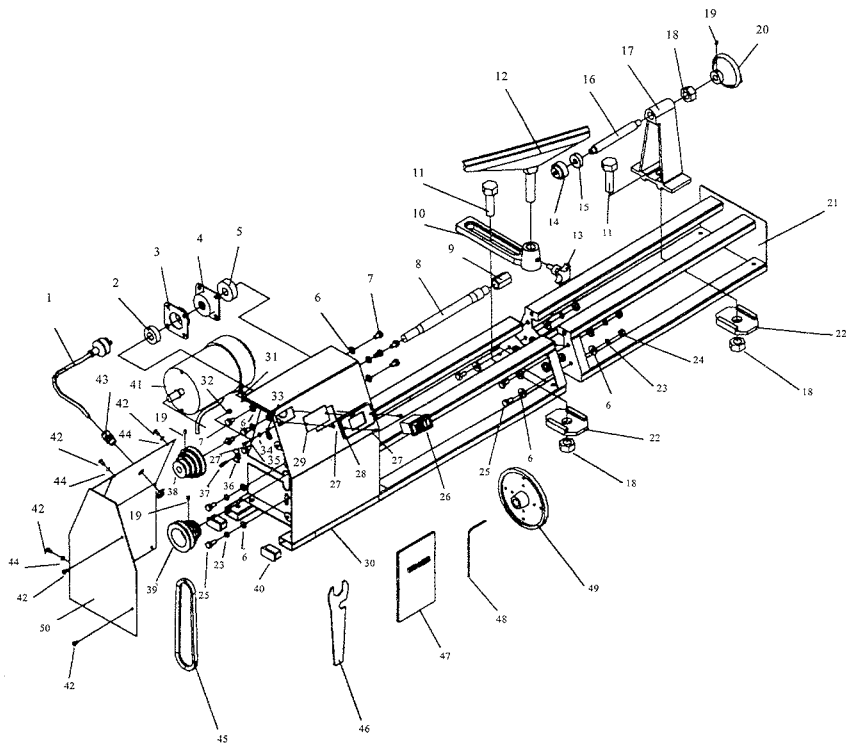

Fig.18

FINISHING.

Turned timber can be power sanded on the lathe using a folded strip of sandpaper across the work. Remove the tool rest so that you have proper access to the workpiece.



No.	Description	Qty	Size	No.	Description	Qty1	Size
1.	Power cable	1		26.	Switch	1	
2.	Ball bearing	1	60203	27.	Screw	6	M4x10
3.	Bearing block	1	203	28.	Switch bracket	1	
4.	Bearing block	1	204	29.	Window	1	
5.	Ball bearing	1	60204	30.	Lath body.	1	
6.	Washer	14	8	31.	Nut	1	M4
7.	Bolt	8	M8x10	32.	Nut	1	M5
8.	Main shaft	1		33.	Washer s teeth	2	4
9.	Lathe tip	1		34.	Washers	2	4
10.	Jip	1		35.	Spring washers	2	4
11.	Cap screw	2	M18x60	36.	Wire bracket	1	
12.	Tool carriage	1	12"	37.	Screw	1	M5x16
13.	Locking screw	1		38.	Belt pulley	1	
14.	Tip	1		39.	Belt pulley	1	
15.	Ball bearing	1	60201	40.	Cover	2	
16.	Screw axis	1	M18	41.	Motor	1	
17.	Tailstock	1		42.	Screw	6	M5x10
18.	Nut	3	M18	43.	Cord clamp	1	
19.	Locking screw	3	M6x8	44.	Washers	4	5
20.	Hand wheel	1		45.	Belt	1	2500
21.	Rear rail	1		46.	Tool handle	1	
22.	Guide track plate	2		47.	Instruction manusl	1	
23.	Spring washer	6	8	48.	Screw driver	1	S3
24.	Nut	4	M8	49.	Chuck	1	
25.	Screw	6	M8x16	50.	Protecting crust	1	

Free Manuals Download Website

<http://myh66.com>

<http://usermanuals.us>

<http://www.somanuals.com>

<http://www.4manuals.cc>

<http://www.manual-lib.com>

<http://www.404manual.com>

<http://www.luxmanual.com>

<http://aubethermostatmanual.com>

Golf course search by state

<http://golfingnear.com>

Email search by domain

<http://emailbydomain.com>

Auto manuals search

<http://auto.somanuals.com>

TV manuals search

<http://tv.somanuals.com>