

Fisher-Price®



Fun Sounds Garage™



Product Number: 77974

Please keep this instruction sheet for future reference, as it contains important information.

Adult assembly is required.

Tool required for battery installation: Phillips Screwdriver (not included).

This product requires three "AAA" (LR03) **alkaline** batteries for operation (not included).

www.fisher-price.com

Parts

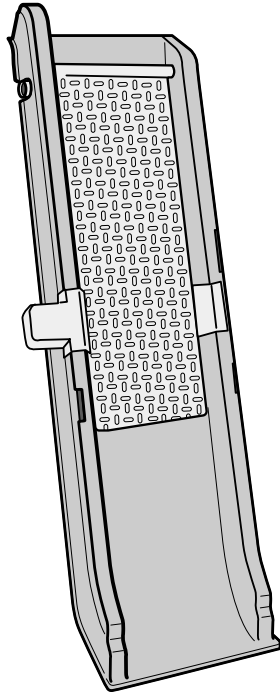

Long Ramp

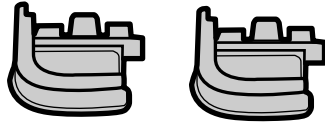

2 Balconies

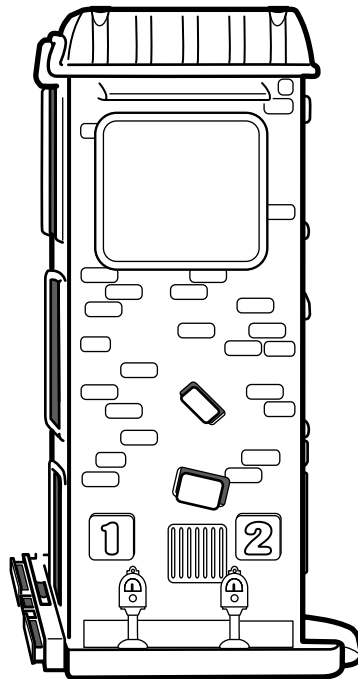

Elevator Shaft

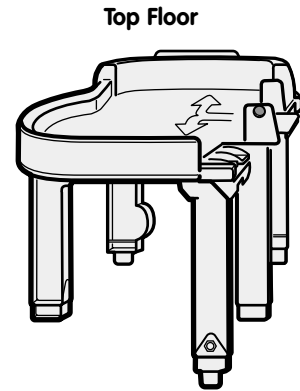

Top Floor

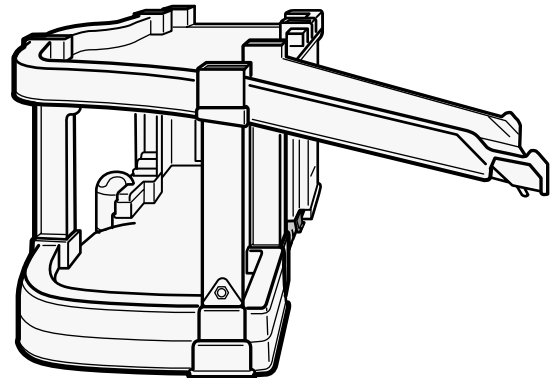

Base

Not Shown: Label Sheet
2 Little People® Figures
Car

Fisher-Price, Inc., a subsidiary of Mattel, Inc. East Aurora, New York 14052, U.S.A.
©2001 Mattel, Inc. All Rights Reserved.® and ™ designate U.S. trademarks of Mattel, Inc.

Assembly

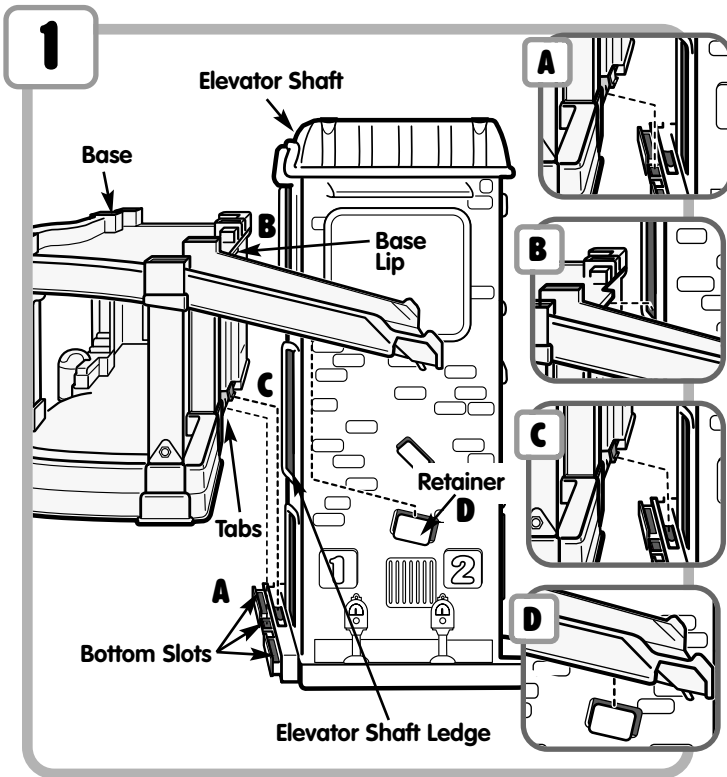

- Position the elevator shaft on a flat surface. Note the locations of the bottom slots, snap slot and retainer on the elevator shaft.
- While holding the base at an angle, fit the locator tabs into the bottom slots in the elevator shaft **A**.
- While making sure the base lip fits over the elevator shaft ledge **B**, insert and snap the hooked tab on the base into the slot in the elevator shaft **C**.
- Insert and snap the tab on the side of the base ramp into the retainer in the elevator shaft **D**.

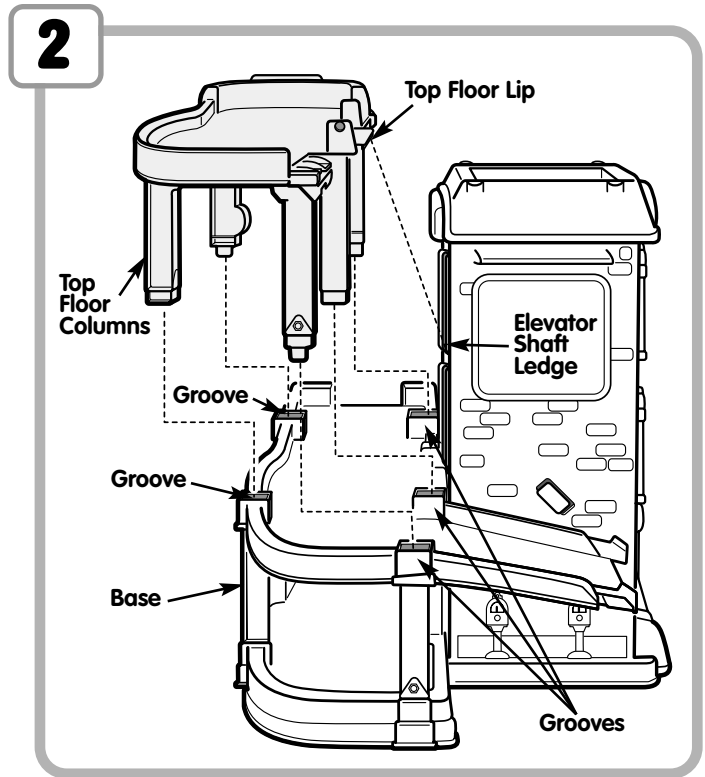

- Insert and snap all five top floor columns into the grooves in the base. Make sure the top floor lip fits over the elevator shaft ledge.

Assembly

3

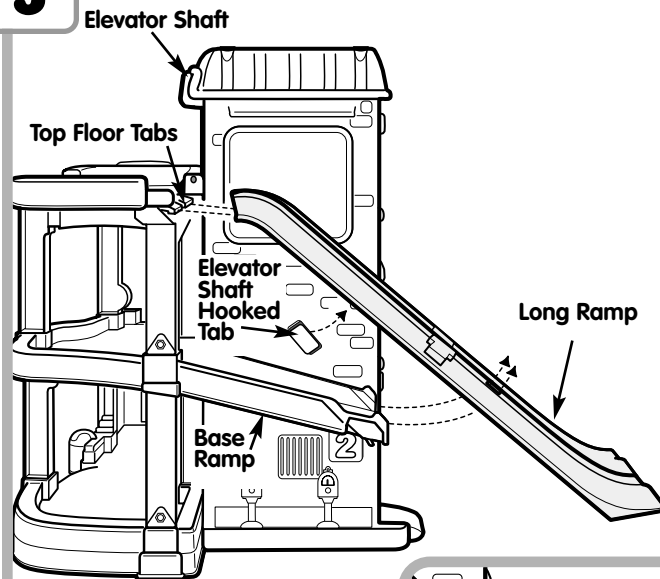

- Fit the three tabs on the top floor into the top end of the ramp.
- Insert and snap the hooked tab on the elevator shaft into the slot in the side of the long ramp.
- Insert and snap the tabs on base ramp into the slots in the long ramp.

4

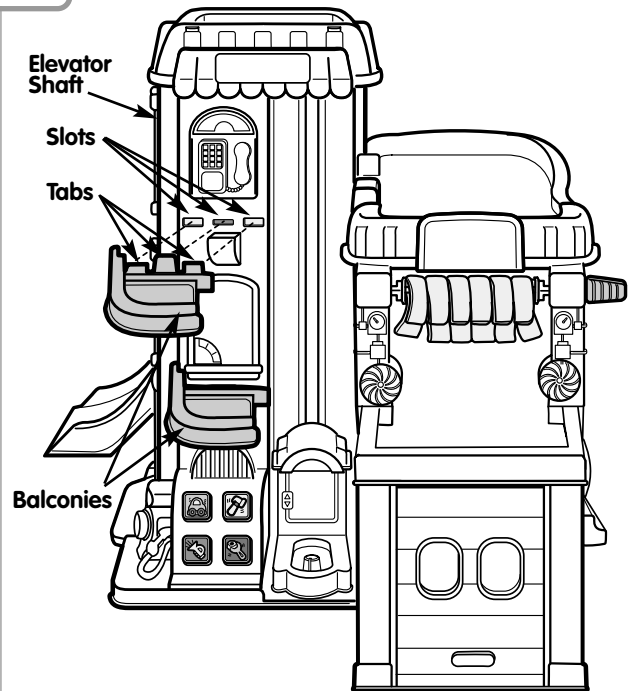

- Insert and snap the tabs on the balconies into the slots in the elevator shaft.
- Assembly is now complete.**

Label Decoration

Proper label application will help to keep the labels looking their best!

- Wash your hands before applying the labels.
- Make sure the areas where the labels will be applied are clean and dry. Wipe this product with a clean, soft, dry cloth to remove any dust or oils.
- For best results, do not attempt to apply a label more than once.
- Apply the labels as shown in the illustrations.

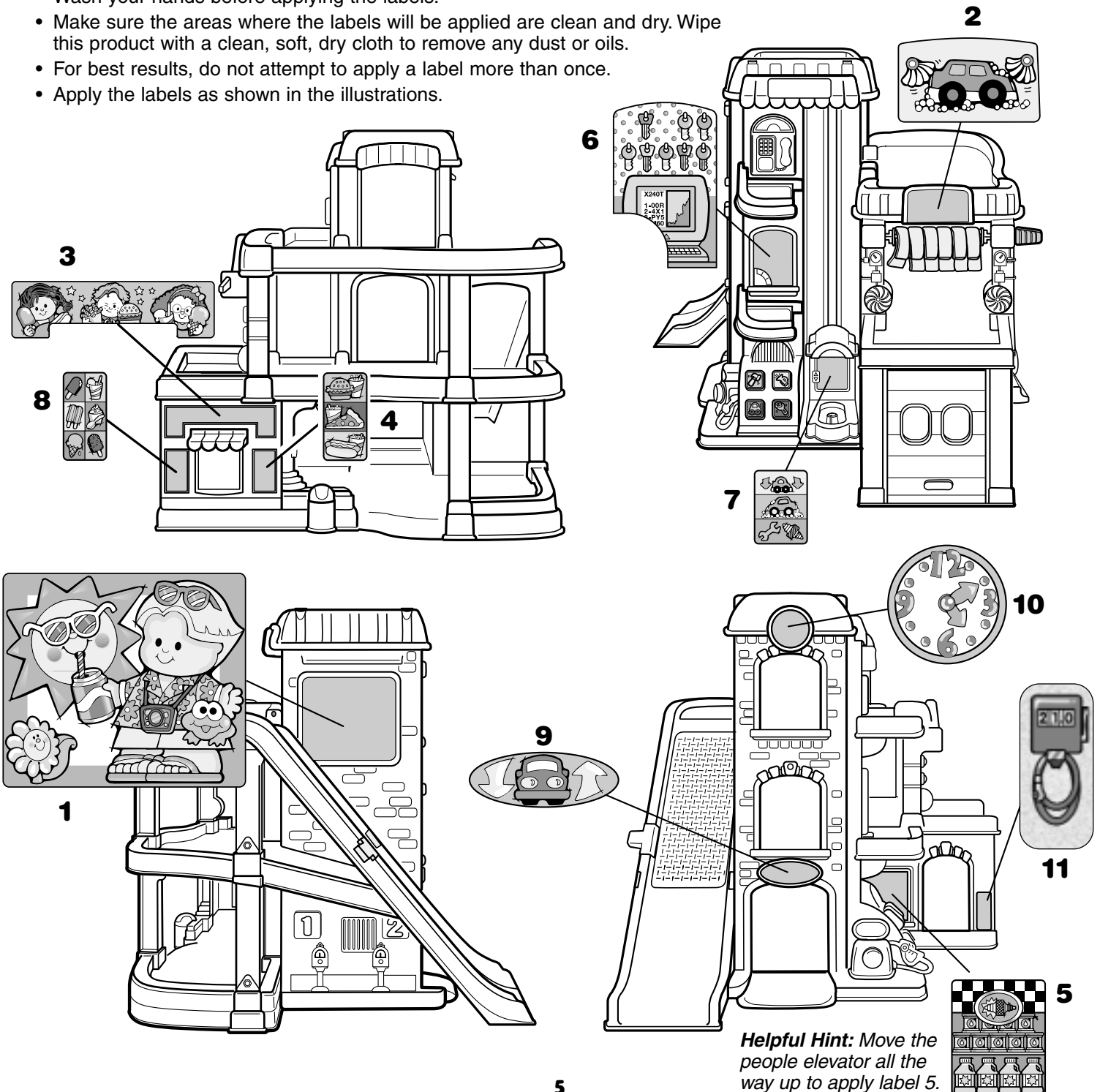

Helpful Hint: Move the people elevator all the way up to apply label 5.

Battery Installation

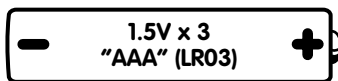
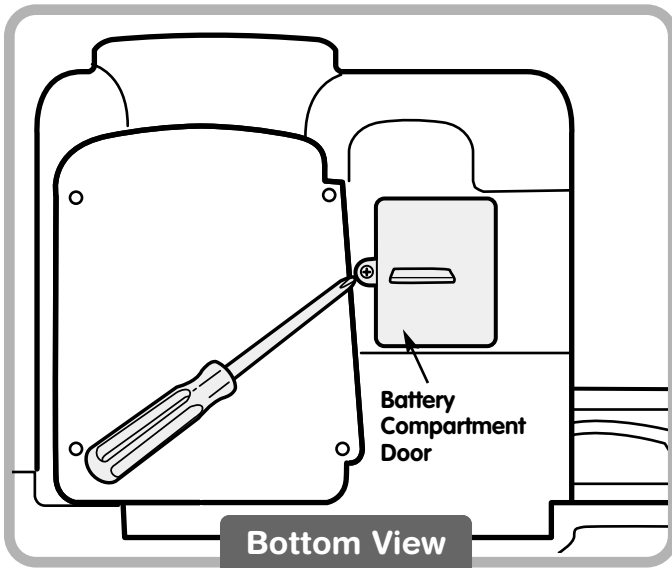

Shown Actual Size

Battery Tips

- Do not mix old and new batteries.
- Do not mix different types of batteries: alkaline, standard (carbon-zinc) or rechargeable (nickel-cadmium).
- Remove the batteries during long periods of non-use. Always remove exhausted batteries from the toy. Battery leakage and corrosion can damage the toy. Dispose of batteries properly.
- Do not dispose of batteries in a fire. The batteries may explode or leak.
- Never short circuit the battery terminals.
- Non-rechargeable batteries are not to be recharged.
- Only batteries of the same or equivalent type as recommended in the "Battery Installation" instructions are to be used.
- If removable rechargeable batteries are used, they are only to be charged under adult supervision.
- Rechargeable batteries are to be removed from the toy before they are charged.
- If you use a battery charger, it should be examined regularly for damage to the cord, plug, enclosure and other parts. Do not use a damaged battery charger until it has been properly repaired.

- Locate the battery compartment on the underside of the elevator shaft.
- Loosen the screw in the battery compartment door with a Phillips screwdriver. Lift to open the battery compartment door.
- Insert three, size "AAA" (LR03) **alkaline** batteries as indicated inside the battery compartment.

Hint: We recommend the use of **alkaline** batteries for longer battery life.

- Replace the battery compartment door and tighten the screw with a Phillips screwdriver. Do not over-tighten.

Let's Fix it Up!

Press any of the buttons to hear fun sounds!

"Ring Ring"

"Ding Ding"

"Beep Beep"

"Cha Ching"

Telephone Button

Cash Register Button

Gas Pump Button

Fun Sounds Buttons

"Honk Honk"

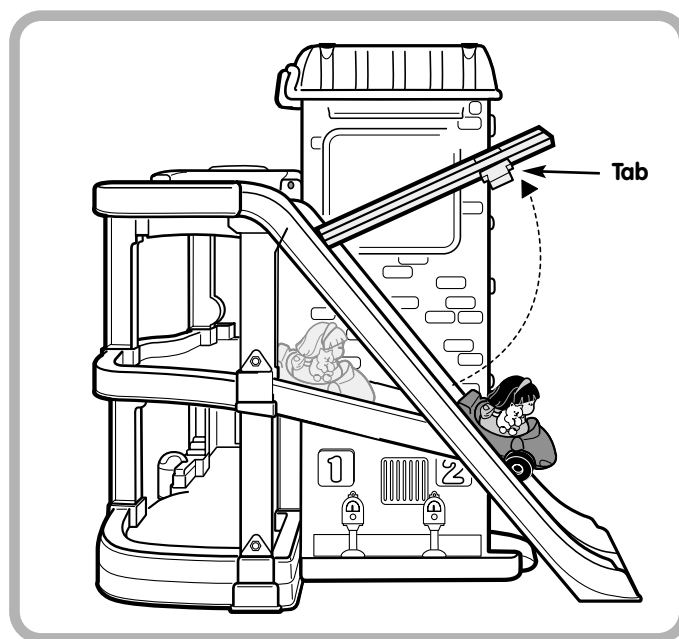
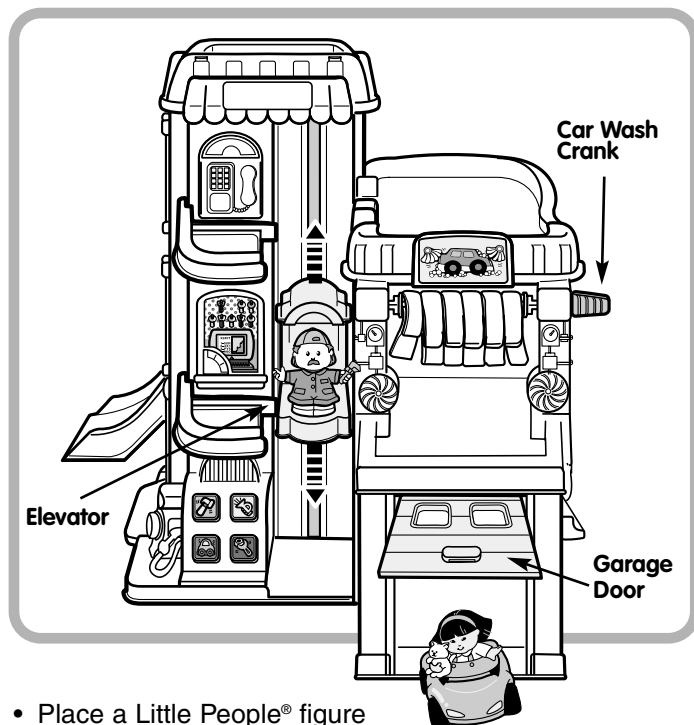

- Place a Little People® figure into the elevator and lift.
- Turn the crank to wash a car.
- Grasp the handle to lift the garage door.

- Grasp the tab and lift the secret trap door.

Care

- Do not immerse any part of this product. Surface wash this toy with a mild detergent and clean, soft cloth.
- If sounds from this toy become faint, or if there is no sound, remove the batteries and dispose of them properly. Replace the batteries with three, "AAA" (LR03) **alkaline** batteries.

Consumer Information

Questions? We'd like to hear from you!

Call Fisher-Price® Consumer Relations, toll-free at **1-800-432-KIDS**, 8 AM - 6 PM EST Monday through Friday. Hearing-impaired consumers using TTY/TDD equipment, please call 1-800-382-7470. Or, write to: Fisher-Price® Consumer Relations, 636 Girard Avenue, East Aurora, New York 14052.

For other countries, outside the United States:

Canada: call **1-800-567-7724**, or write to: Mattel Canada Inc, 6155 Freemont Blvd., Mississauga, Ontario L5R 3W2. **Great Britain:** telephone 01628 500303.

Australia: Mattel Australia Pty. Ltd., 658 Church Street, Locked Bag #870, Richmond, Victoria 3121 Australia. Consumer Advisory Service 1300 135 312.

New Zealand: 16-18 William Pickering Drive, Albany 1331, Auckland.

FCC Note (United States Only)

Note: This equipment has been tested and found to comply with the limits for a Class B digital device, pursuant to Part 15 of the FCC Rules. These limits are designed to provide reasonable protection against harmful interference in a residential installation. This equipment generates, uses and can radiate radio frequency energy and, if not installed and used in

accordance with the instructions, may cause harmful interference to radio communications. However, there is no guarantee that interference will not occur in a particular installation. If this equipment does cause harmful interference to radio or

television reception, which can be determined by turning the equipment off and on, the user is encouraged to try to correct the interference by one or more of the following measures:

- Reorient or relocate the receiving antenna.
- Increase the separation between the equipment and receiver.
- Consult the dealer or an experienced radio/TV technician for help.

CAUTION: Changes or modifications not expressly approved by the manufacturer responsible for compliance could void the user's authority to operate the equipment.

Free Manuals Download Website

<http://myh66.com>

<http://usermanuals.us>

<http://www.somanuals.com>

<http://www.4manuals.cc>

<http://www.manual-lib.com>

<http://www.404manual.com>

<http://www.luxmanual.com>

<http://aubethermostatmanual.com>

Golf course search by state

<http://golfingnear.com>

Email search by domain

<http://emailbydomain.com>

Auto manuals search

<http://auto.somanuals.com>

TV manuals search

<http://tv.somanuals.com>