

# Trabon Divider Valves

312497F

EN

**For series progressive, oil and grease lubrication. For Professional Use Only.**



**Important Safety Instructions**  
Read all warnings and instructions in this manual. Keep these instructions.

## Models/Maximum Pressure

**Table 1: Maximum Pressure Lube Points**





Divider Type	Maximum Operating Pressure kPSI (MPa, bar)	Maximum Sections
<b>MD</b>	3.0 (20.7, 207)	2
<b>MJ/MJSS</b>	2.0 (13.8, 138)	8
<b>MSP</b>	3.5 (24.1, 241)	8
<b>MHH</b>	7.5 (51.7, 517)	8
<b>MX</b>	3.0 (20.7, 207)	10
<b>MXP</b>	3.0 (20.7, 207)	10
<b>MGO</b>	See Table 2	11

**Table 2: MGO Series-Flo Divider Maximum Operating Pressures**

Maximum Operating Pressure kPSI (MPa, bar)	Number of Sections
6.0 (41.4, 414)	<b>3 to 7</b>
5.5 (37.9, 379)	<b>8</b>
4.0 (27.6, 276)	<b>9</b>
4.5 (31.0, 310)	<b>10</b>
4.0 (27.6, 276)	<b>11</b>

# Warnings

The following Warnings are for the setup, use, grounding, maintenance and repair of this equipment. The exclamation point symbol alerts you to a general warning and hazard symbols refer to procedure-specific risks. Refer back to these Warnings. Additional, product-specific warnings may be found throughout the body of this manual where applicable.

 <b>WARNING</b>	
	<p><b>EQUIPMENT MISUSE HAZARD</b></p> <p>Misuse can cause death or serious injury.</p> <ul style="list-style-type: none"> <li>• Do not operate the unit when fatigued or under the influence of drugs or alcohol.</li> <li>• Do not exceed the maximum working pressure or temperature rating of the lowest rated system component. See <b>Technical Data</b> in all equipment manuals.</li> <li>• Use fluids and solvents that are compatible with equipment wetted parts. See <b>Technical Data</b> in all equipment manuals. Read fluid and solvent manufacturer's warnings. For complete information about your material, request MSDS forms from distributor or retailer.</li> <li>• Check equipment daily. Repair or replace worn or damaged parts immediately with genuine manufacturer's replacement parts only.</li> <li>• Do not alter or modify equipment.</li> <li>• Use equipment only for its intended purpose. Call your distributor for information.</li> <li>• Keep children and animals away from work area.</li> <li>• Comply with all applicable safety regulations.</li> </ul>
 	<p><b>SKIN INJECTION HAZARD</b></p> <p>High-pressure fluid from dispense valve, hose leaks, or ruptured components will pierce skin. This may look like just a cut, but it is a serious injury that can result in amputation. <b>Get immediate surgical treatment.</b></p> <ul style="list-style-type: none"> <li>• Do not point dispense valve at anyone or at any part of the body.</li> <li>• Do not put your hand over the end of the dispense nozzle.</li> <li>• Do not stop or deflect leaks with your hand, body, glove, or rag.</li> <li>• Follow <b>Pressure Relief Procedure</b> in this manual, when you stop spraying and before cleaning, checking, or servicing equipment.</li> </ul>

## Pressure Relief Procedure

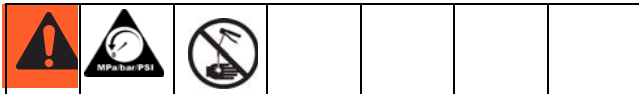

Follow this **Pressure Relief Procedure** whenever you are instructed to relieve pressure or check or service equipment.

1. Verify pump feeding valve is stopped and disconnected from, or locked out of it's driver.
2. Using a wrench, slowly loosen inlet nut.
3. Then, using a wrench, slowly loosen each port nut.

# Setup

The divider valve is shipped ready to install in your system. It has been factory-tested and should not require any additional modification.

## NOTICE

Do not install a divider valve into a system rated for more than the valve's maximum operating pressure. This type of installation could result in o-ring damage and cause the divider valve to leak.

To install the divider valve in your system:

1. Determine an appropriate, remote mounting location.
2. Install a rupture to atmosphere fitting with a blow-out disk that is rated for 7,500 psi or less between the force feed lubricator pump and master divider valve inlet.
3. Install an analog pressure gauge at the inlet to the divider valve.
4. Install a slow or no cycle shutdown in one of the piston enclosure plugs. Program it to shut down after no more than 180 seconds without a complete cycle.
5. Torque. See Table 4 on page 15.

As long as lubricant is supplied under pressure to the inlet section of the divider assembly, valves sections will continue to operate in a progressive manner. Divider assemblies always follow a constant discharge pattern. Whenever lubricant flow ceases, the valving pistons will stop. When flow resumes, it will start again at the same point in the discharge cycle.

## Component Identification

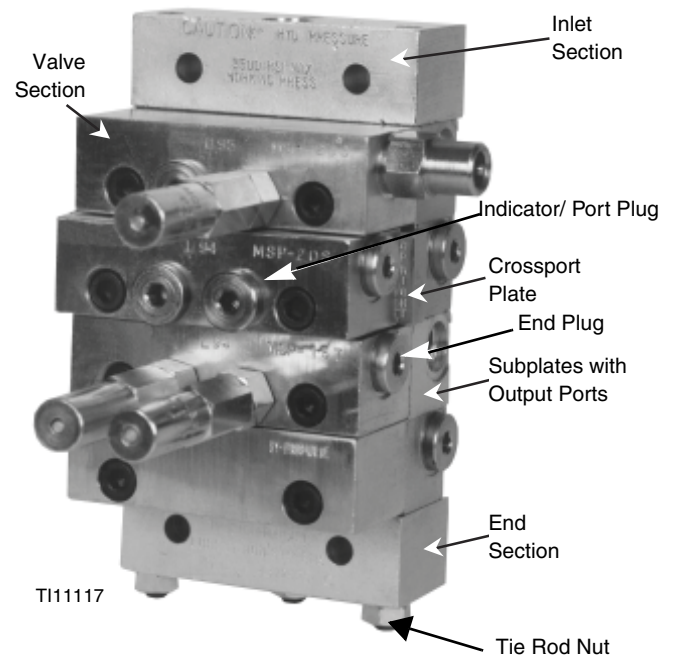

FIG. 1

Table 3: Typical Divider Valve Combinations

MASTER	SECONDARY	TYPE OF APPLICATION
MJ	MD	Machine tools, Printing, Wire Forging & Packaging Machinery
MSP	MJ, MSP	Machine tools, Textile, Glass & Can Machinery, Mobile Equipment
MX, MXP	MX, MXP, MSP	Cranes, Presses, Steel Mills, etc.
MGO	MX	Levellers, Shears, Conveyors, etc.

## Divider Valves

A Series-Flo type divider valve is a manifold proportioning device consisting of an inlet and end section plus a minimum of three valve sections. The divider valve is manifolded together with tie rods and nuts. A master divider valve is the first divider valve downstream from the lube pump. A secondary divider valve is any divider valve receiving lubricant from the master divider valve.

## Valve Sections (MSP, MHH and MXP modular-type, divider valves, only)

Valve sections (three or more required per manifold) contain a piston specially fitted to that section, built in outlet check valves and various passageways that, working with the piston, meters and valves the flow of lubricant (FIG. 2).

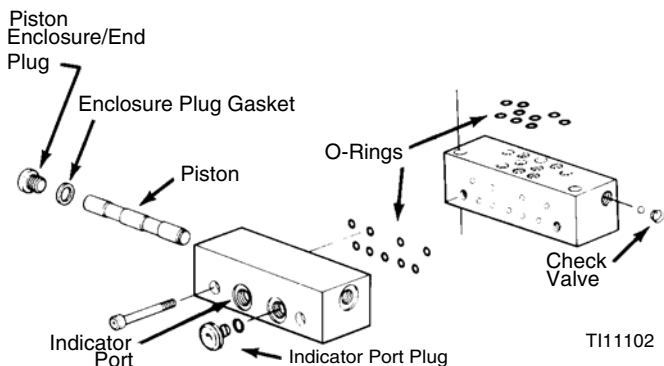

FIG. 2

Valve sections may be manufactured to require one or two lube outlets. Stamping located on the face of each section indicates:

- the style of divider valve section, i.e., MSP, MX, etc.,
- the discharge per piston stroke expressed in thousandths of cubic inches ( $35 = .035 \text{ in}^3$ ) and,
- the number of lube outlets required (S = single, one outlet only; T = twin, two lube outlets required).

## Prefilling Lubricant Distributor Lines

Follow the following procedure *exactly* as written, in the order written.

### NOTICE

- The initial startup and operation is the most critical operating period for a newly installed machine in terms of potential for being damaged by unre-moved/unfiltered lubricant contaminants and lack of adequate lubrication. Proper prefilling of lubrication system ensures that lubricant is immediately available to every lube point during machine startup, protecting them from damage.
- Use only clean oil filtered to the SAE -recommended cleanliness level of ISO 18/14 (ISO Standard 4406) when prefilling a system. The manufacturers of the machine tool and its component bearings should be consulted to ensure that the ISO 18/14 cleanliness level is adequate.

## Filling Secondary-to-Lube Point Lines

Refer to FIG. 3. when performing this procedure

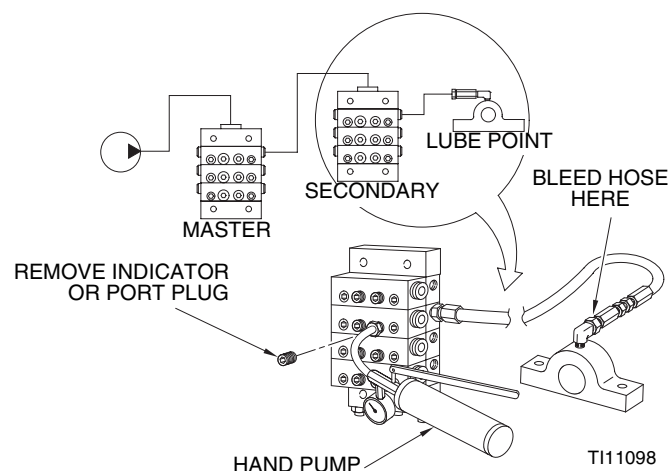

FIG. 3

1. Remove port plugs or performance indicators from all of the indicator ports on front of secondary divider valves.
2. Connect a hand pump filled with clean, filtered lubricant to the indicator port closest to the first line to be filled that corresponds to the output port that is feeding the line to be filled.

3. In order to verify when lubricant is flowing and has reached the end of the lube line, loosen the connector at the lube point of the line that is to be filled.
  4. Stroke the hand pump until air-free lubricant is observed flowing from the end of the lube line.
  5. Tighten the lube line connector at the lube point, but do not replace the port plugs or performance indicators into the ports on the front of the working section.
  6. Repeat steps 1-5 for each of the other lube lines connected to the other outlet ports in the secondary divider valve assembly and for any other secondary divider assemblies in the system.
4. Continue to stroke the pump until the lubricant purges all the air out of the internal passages of the secondary divider valve and lubricant flows freely from all indicator ports with no evidence of included air.
  5. Reinstall the port plugs or performance indicators in their respective positions in the secondary divider valve. Do not replace the port plugs or performance indicators in the master divider valve yet.
  6. Repeat Steps 1-5 for each of the other lube lines between the master divider valve and all other secondary divider valves.

**NOTE:** Do not replace any of the performance indicators or port plugs removed in Step 1 until the line-filling procedure described in Section 2 (Filling Master -to-Secondary Lube Lines) has been completed.

**NOTE:** Do not replace any of the performance indicators or port plugs removed in Step 1 from the master divider valve assembly until the air-purging procedure described in Section 3 (Filling Master Divider Valve) has been completed.

### Filling Master-to-Secondary Lube Lines

Refer to FIG. 4. when performing this procedure.

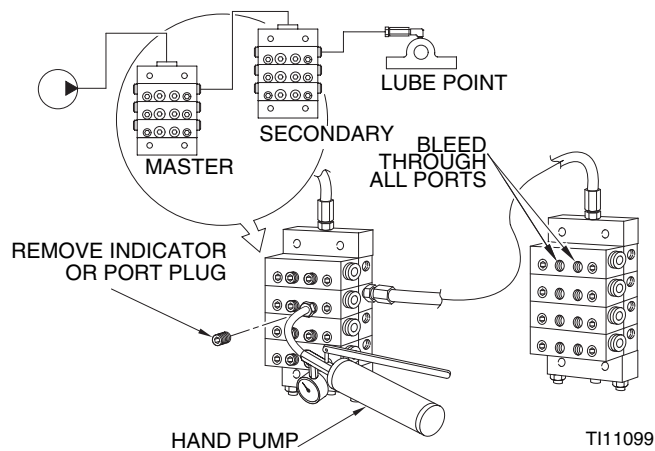
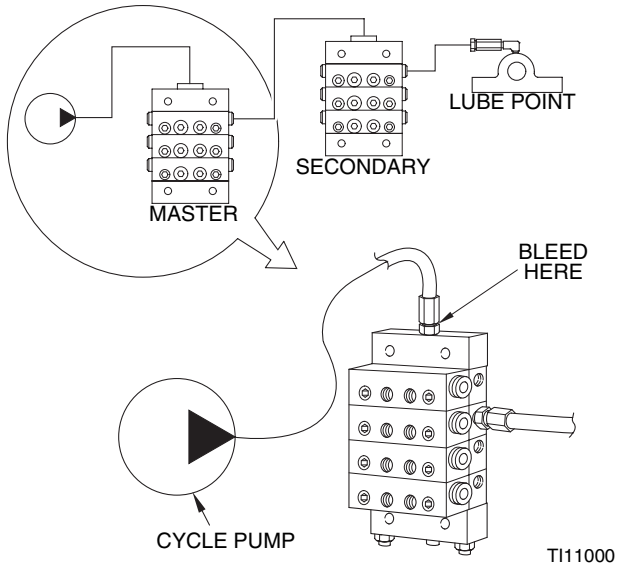

**FIG. 4**

1. Remove the port plugs or performance indicators from all the indicator ports on the front of the master divider valve.
2. Connect a hand pump filled with clean, filtered lubricant to the indicator port closest to the lube output port that is feeding the line to the secondary divider valve.
3. Stroke the hand pump to fill the line between the master divider valve and secondary divider valve.

## Filling Master Divider Valve

Refer to FIG. 5. when performing this procedure.

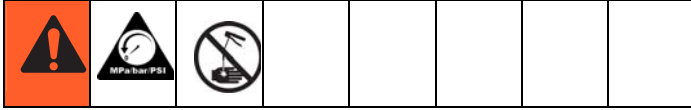

**FIG. 5**

1. Verify that all port plugs or performance indicators have been removed from all indicator ports in the master divider valve.
2. Verify that the system pump is properly connected to the inlet port of the master divider valve.
3. Cycle the system pump sufficiently to fill the main feeder line between the pump and the master divider valve and the lubricant is observed being discharged from all of the indicator ports on the front of the master divider valve with no evidence of included air.
4. Reinstall the master divider valve port plugs or performance indicators into their respective positions.

# Repair

## General Repair Instructions



- Before performing any repair procedures, **relieve pressure**, page 2.
- Pressure test distribution blocks yearly or every 8000 hours. Replace seals and divider valves as necessary.

## Purging Air From the System

Before machine operation is resumed following maintenance or repair, manual system air purging must be performed.

There are several air purging procedures available depending upon the maintenance or repair procedure.

**NOTE:** Use only clean oil filtered to the SAE -recommended cleanliness level of ISO 18/14 (ISO Standard 4406) when prefilling a system. The manufacturers of the machine tool and its component bearings should be consulted to ensure that the ISO 18/14 cleanliness level is adequate.

Page	Section	Air purging after:
8	1	Replacing line between a secondary divider valve and lube point.
9	2	Replacing a line between the master divider valve and a secondary divider valve.
10	3	Replacing a line between pump and master divider valve.
11	4	Adding or replacing any component in a master divider valve assembly.
12	5	Adding or replacing any component in module in a secondary divider valve assembly.

## Section 1: Purging Air from Secondary Divider Valve Lube-to-Lube Point Lines

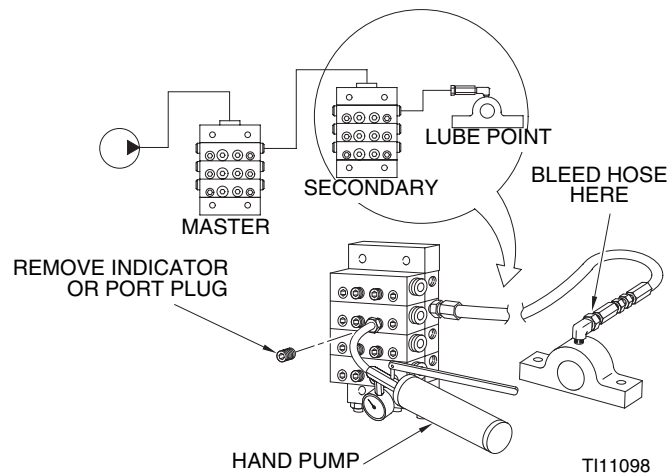

FIG. 6

Steps 1-6, refer to FIG. 6.

1. Install the line from the secondary divider valve to the lube point, but do not completely tighten the connection at the lube point.
2. Remove the performance indicator port plug or the performance indicator from the working valve section on the secondary divider valve assembly corresponding to the outlet port and the line connected to the lube point.
3. Attach a hand pump filled with clean, filtered lubricant to the port on the secondary divider valve that was opened in Step 2.
4. Operate the hand pump until air-free lubricant is observed flowing from the line at the lubrication point.
5. Tighten the fitting at the lubrication point while lubricant is still flowing.
6. Remove the hand pump and reinstall the performance indicator or indicator port plug removed in Step 2.

**NOTE:** If check valves were not installed at the lubrication point, lubricant may continually drain out of the line when the secondary port is open. Therefore, when check valves are not used, the method for bleeding this line is to tighten the line at both ends and repeatedly cycle the secondary divider valve via hand pump operation until lubricant, free of air, flows from the lubrication point



## Section 2: Purging Air from Master to Secondary Divider Valve Lube Lines

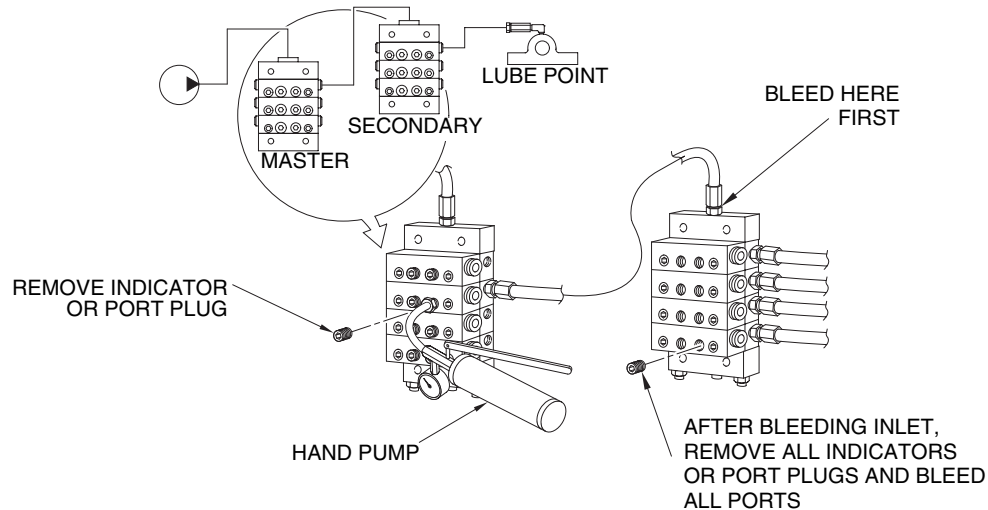

**FIG. 7**

Steps 1- 9, refer to FIG. 7.

1. Install the lines from the master divider valve to the secondary divider valve, but do not completely tighten the connection at the secondary divider valve's inlet.
2. Remove the performance indicator port plug or the performance indicator from the working valve section on the master divider valve assembly corresponding to the outlet port and the line connected to the secondary valve.
3. Attach a hand pump filled with clean, filtered lubricant on the master divider valve that was opened in Step 2.
4. Operate the hand pump until air-free lubricant is observed flowing freely from the secondary valve's lube inlet connector.
5. Tighten the fitting at the secondary valve's inlet while lubricant is still flowing.
6. Remove all of the indicators or indicator port plugs from the secondary divider valve's working sections.
7. Operate the hand pump again until air-free lubricant is observed flowing out of all the secondary divider valve's indicator ports.
8. Reinstall all of the performance indicators or port plugs in the secondary divider valve while lubricant is still flowing from the ports.
9. Remove the hand pump and reinstall the performance indicator or indicator plug removed in Step 2 into the master divider working valve's open port.

The system is now ready for operation.

### Section 3: Purging Air from Pump to Master Divider Valve Lines

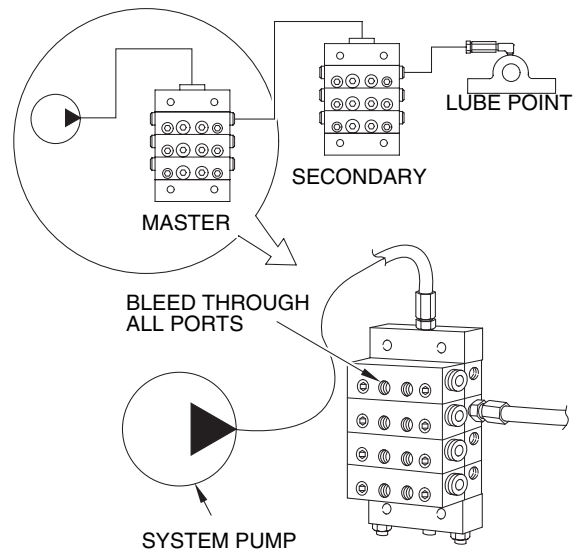

TI11114

**FIG. 8**

Steps 1-3, refer to FIG. 8.

1. Install the line from the system pump to the master divider valve, but do not completely tighten the connection at the master valve's lube inlet.
2. Cycle the system pump until air-free lubricant is observed flowing from the line at the master divider valve's lube inlet.
3. Tighten the fitting at the lube inlet port while lubricant is still flowing.

The system is now ready for operation.

## Section 4: Purging Air After Adding or Replacing a Master Divider Valve Module

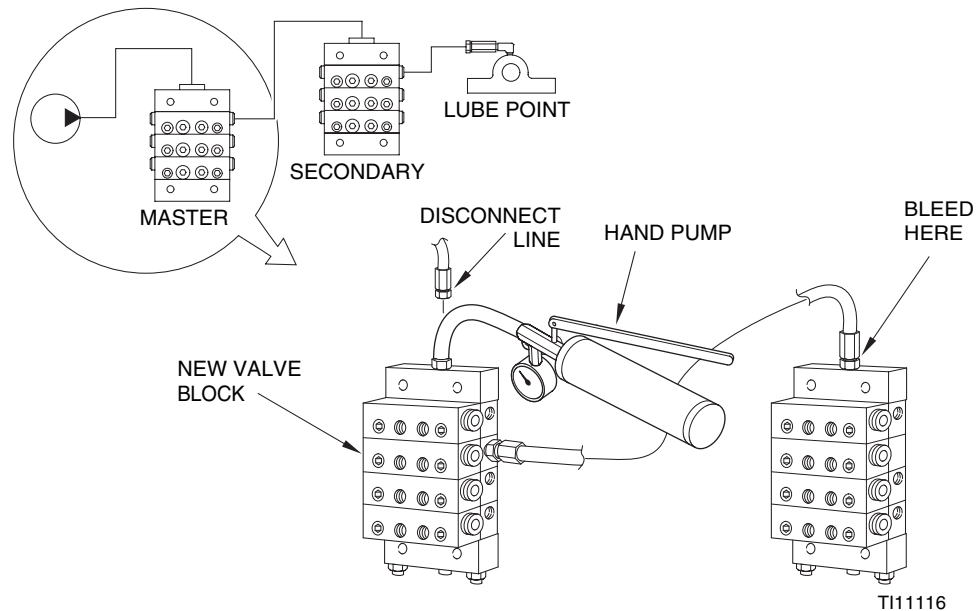

**FIG. 9**

Steps 1-7, refer to FIG. 9.

1. Install the new or replacement module into the master divider valve assembly. Also connect the tubing or hoses to the appropriate secondary divider valve(s) or lubrication point(s) if the new/replacement module is a base section.
2. Do not completely tighten the connection(s) at the secondary divider valve's inlet or at lubrication points.
3. Disconnect and remove the line from the pump at the inlet of the master divider valve.
4. Attach a hand pump filled with clean, filtered lubricant to the inlet port on the master divider valve.
5. Operate the hand pump until air-free lubricant is observed flowing from each secondary valve's lube inlet connector and/or each lubrication point's connector.
6. Tighten the fitting at the secondary valve inlet or at the lubrication port while lubricant is still flowing.
7. Remove the hand pump and reconnect the system pump to the inlet of the master divider valve.

The system is now ready for operation.

## Section 5: Purging Air After Adding or Replacing a Secondary Divider Valve Module

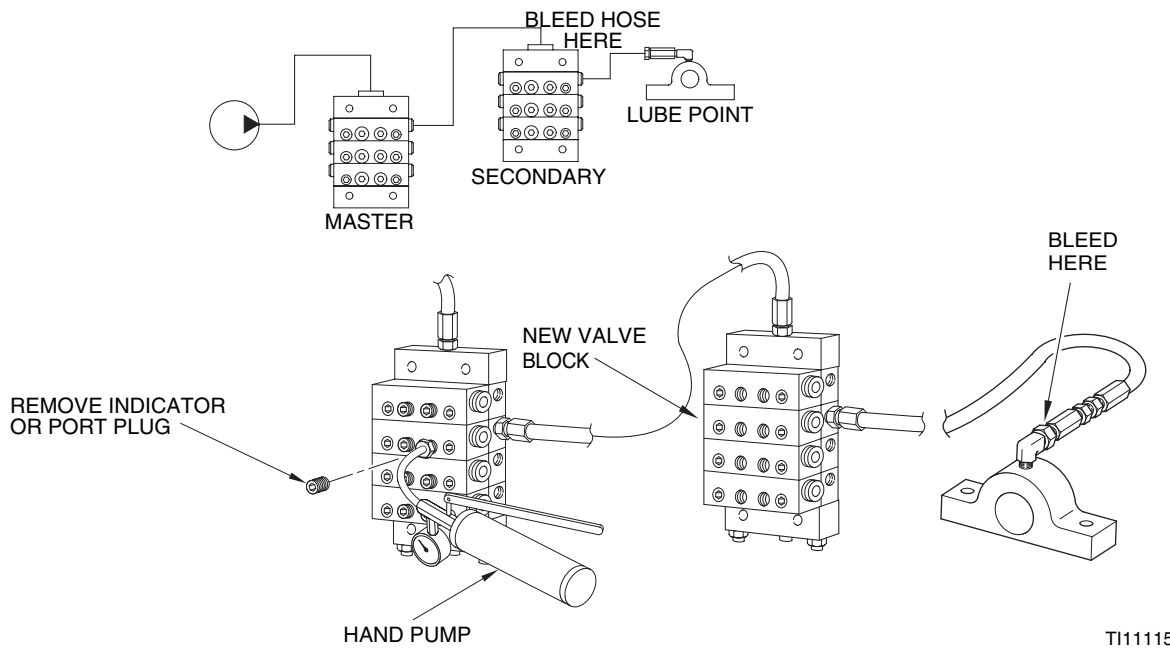

**FIG. 10**

Steps 1-8, refer to FIG. 10.

1. Install the new or replacement module to the secondary divider valve assembly. Also connect the tubing or hoses to the appropriate lubrication point if the new/replacement module is a base section.
  2. Do not completely tighten the connection(s) at the lubrication point.
  3. Remove the performance indicator or indicator port plug from the working valve section on the secondary divider valve assembly corresponding to the outlet port and line connected to a particular lube point.
  4. Attach a hand pump filled with clean, filtered lubricant to the port on the secondary divider valve that was opened in Step 3.
  5. Operate the hand pump until air-free lubricant is observed flowing from the loosened connector at the lube point.
  6. Tighten the fitting at the lube point while lubricant is still flowing.
  7. Repeat Steps 3 - 6 for any additional lubrication points connected to the new module.
  8. Remove the hand pump and reinstall the performance indicator or port plug removed in Step 3 into the secondary divider valve's open port.
- The system is now ready for operation.

## Locating and Repairing Blockages

Blocks will cause a higher than normal pumping pressure. Depending on the application or system design, this blockage will usually result in a complete loss of lubricant flow into the total system and no bearing will be receiving lubrication.

The loss of flow due to a blockage is first indicated with the higher than normal system pressure that is developed by the pump as it attempts to overcome this blockage. Higher pressure is limited, isolated and signaled through the use of various performance indicators, reset and relief, incorporated into the system design.

### Performance Indicators

Performance indicators are pressure-sensitive devices that pinpoint excessive pressure in the lubricating system.

These devices are installed in the indicator ports of divider valves, signal a fault either by causing an indicator pin to protrude or by releasing lubricant into the atmosphere.

**NOTE:** Never block a lube outlet that is designed to discharge lubricant.

### Reset Indicator with Memory

Reset indicators stop lube system operation when a fault occurs. These devices can be used in either master or secondary divider valves.

When a lube line becomes blocked, the resultant high pressure pushes the indicator pin through the opening in the cap. The high pressure prevents the affected divider valve piston from completing its cycle, causing a pressure backup through the divider valve which trips a pressure switch upstream from the valve and shuts off the pump.

The indicator pin remains extended until it is reset manually. This helps locate the lube line that is blocked.

### Rupture Indicator

Rupture indicators are used on MSP/MH divider valve applications where lube system pressure exceed 2500 psi. The high pressure from the lube line blockage causes a disc to rupture. The lubricant then forces an indicator to protrude, locating the blockage. The high pressure backs up through the system and trips a switch to shut the system off. When the fault is corrected, the disc must be replaced and the pin reset manually.

### Automatic Relief Indicator

An automatic relief indicator pinpoints lube line blockage but allows the lube system to continue supplying lubricant to points that are not blocked. They are used primarily in secondary divider valves. The excessive pressure created by line blockage moves a piston, enabling the lubricant to escape through a vent. When the pressure is relieved, the spring resets the piston. Because these devices permit the lube system to keep operating when a lube point is blocked, a separate pressure switch connected to an audible alarm should be used to warn of high pressure.

## Locating and Repairing Blockages

1. Make a visual inspection of the system. Check for crushed lines or improper divider valve installation.
2. Verify that each divider valve outlet required to discharge lubricant can do so and that no pipe plugs have been installed in an outlet designed to serve a bearing or another divider valve.
3. Use a manual pump with a gauge. Fill the pump with clean, filtered lubricant. Connect the manual pump to the inlet of the master divider valve and slowly operate pump. If system will not cycle freely, below 1500 psi, see Master Divider Valve Equipped with Performance Indicator [Step 4a (below)].

**NOTE:** Use only clean oil filtered to the SAE -recommended cleanliness level of ISO 18/14 (ISO Standard 4406) when prefilling a system. The manufacturers of the machine tool and its component bearings should be consulted to ensure that the ISO 18/14 cleanliness level is adequate.

**4a. Master Divider Valve Equipped With Performance Indicator**

With manual pump connected to the master divider valve as outlined in Locating Blockages, Step 3, raise pressure to 2000 psi. The indicators in the indicator ports will signal the location of the blockage. An indicator in the up position indicates pressure is in that outgoing line and signals the blockage is in the area being served from this outlet (FIG. 11).

If no indicator pins are protruding, the blockage is in the master divider valve.

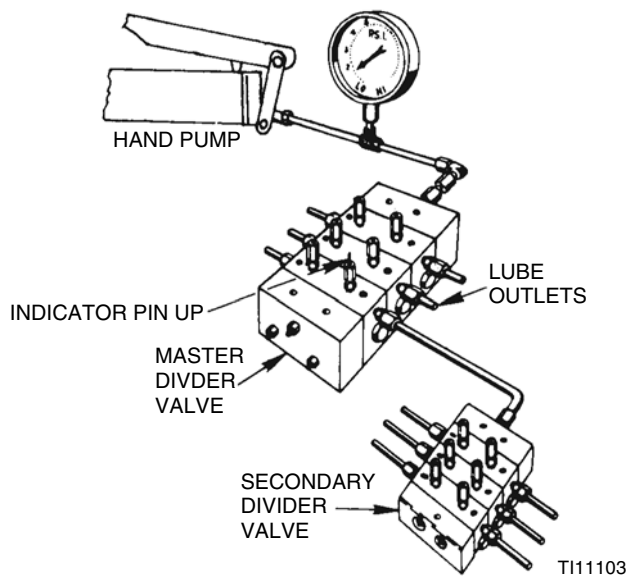

**FIG. 11**

**4b. Master Divider Valve Equipped Without Performance Indicator**

- 1) With manual pump connected to the master divider valve as outlined in Locating Blockages, Step 3, raise pressure to 2000 psi.
- 2) Remove, one at a time, each indicator port plug and attempt to operate manual pump after each plug is removed. Do not exceed 2000 psi.
- 3) If pressure drops and the master cycles freely after an indicator port plug is removed, then blockage is downstream in the area that is being served from that outlet. See Locating Blockages, Step 3.

**NOTE:**

- If all indicator port plugs are removed, the master will not cycle. Blockage is in this divider valve.
- When indicator port plug of a blocked area is removed, a small shot of trapped lubricant will usually surge out of this outlet as the inlet pressure on the divider valve drops.
- If testing (Step 4) indicates a blockage in the master divider valve, this divider valve must be disassembled and cleaned. See Clean Divider Valve, Step 7, page 15.

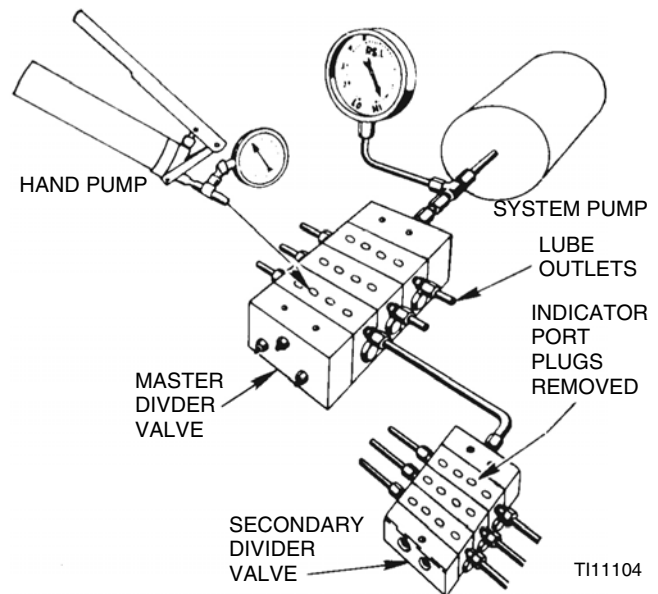

**FIG. 12**

5. If in Step 4, a blockage has been indicated downstream of the master divider valve, install a manual pump in the indicator port of the master divider valve that is common to the blocked area. (See FIG. 12).
  - a. Proceed to downstream secondary divider valve and remove all indicator port plugs.
  - b. Slowly operate manual pump. If lubricant can be discharged freely through each of the indicator ports of this divider valve, the blockage is not in the supply line or the divider valve. Go to step 6.

If lubricant is not freely discharged through open indicator ports of the second divider valve, the blockage is in this divider valve or its supply line. Disconnect supply line at secondary inlet

fitting and slowly operate manual pump to verify location. If blockage is in this divider valve, go to step 7.

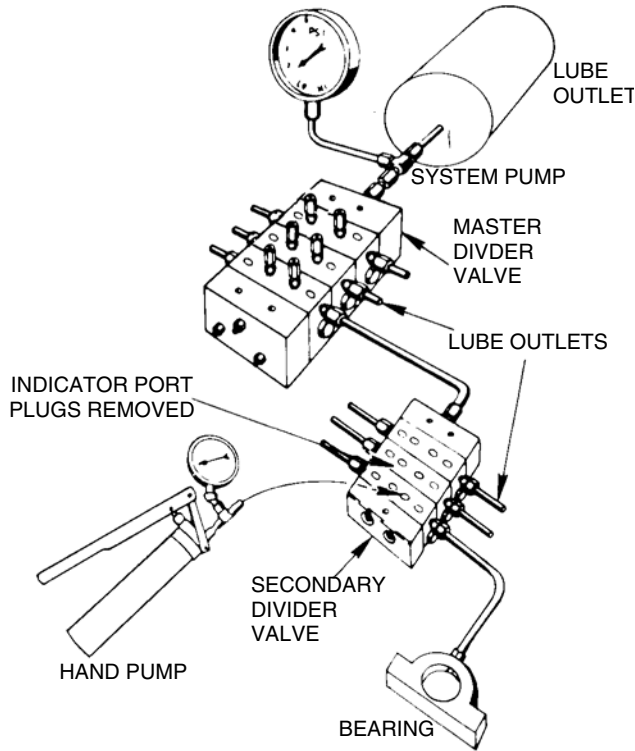

FIG. 13

6. Install manual pump into each indicator port of secondary divider valve in turn and slowly operate pump (FIG. 13). If high pressure exists, blockage has been located. Look for **crushed line, tight bearing, improperly drilled fittings and/or lube inlet port**. Correct as necessary.
7. Clean Divider Valve

**NOTE:** Dirt and foreign material will damage lubricating equipment. Perform all service and disassembly under the cleanest possible conditions.

- a. Before disassembling any divider valve, make a sketch noting the arrangement of Valve Sections. For example: INLET 10T - 20S - 10T - 30S - END (FIG. 14). Also remove end plugs only and try to move each piston back and forth without removing the piston from the valve section.

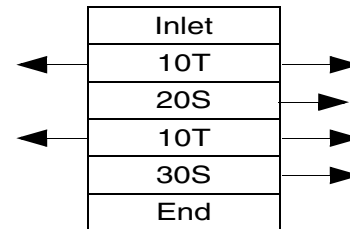

FIG. 14

**NOTICE**

Do not insert hard metal objects into piston bore (i.e., punches, screwdrivers, etc.). Hard metal objects can damage the surface and cause divider valves to leak fluid. Use a brass rod and hand pressure only.

- b. If all pistons move freely and there is no indication of a more serious problem, replace end plugs.
- c. Using a new gasket, tighten and torque as indicated in Table 1 (page 11).

Table 4: Torque Values (\*see FIG. 1, page 3)

	Assembly Torque (ft-lbs)					
	MJ	MD	MSP/MH	MX	MXP	MGO
Tie Rod Nuts	12		5-8	23	6-9	12
Indicator Plugs*	6-7	15	8-9	18	12-15	6-8
End Plugs*	11-13		12-15	46	46-50	15
Valve Section Mounting Screw	-	-	8-9	-	12-13	-

- d. Clean sections and pistons in suitable clean solvent until all lubricant has been removed.
- e. Use compressed air to dry and blow out all ports thoroughly.

A small metal probe should be used to make sure all passages are clean and open.

Inspect cylinder bore and piston carefully for scratches, score marks or other damage.

**NOTE:** If either piston or cylinder bore is damaged, a new section must be installed. All pistons are selectively fitted to the bore for proper clearance. Be sure to reinstall piston only into the valve section from which it was removed.

- f. If divider valve section and piston both appear in good condition, reassemble section making certain piston slides smoothly but snugly in cylinder bore.
- g. Repeat cleaning and inspection of each section. After all sections have been cleaned, blown out, inspected and found to be in good condition, reassemble divider valve using notes and sketches (Step 7) as a reference.

**NOTE:**

- Always use new gaskets.
- Test operation of divider valve using manual pump.

**Contamination Blockage**

If dirt, foreign material or any other form of contamination is found in a divider valve, cleaning that divider valve will only temporarily solve contamination blockage problems. The source of the contamination must be eliminated for satisfactory service.

The system filtering method must be investigated, filter elements should be inspected and cleaned if necessary.

The reservoir filling method should be reviewed to eliminate any chance of foreign material entering the reservoir during filling.

**Separation Blockage**

If a hard wax or soap-like material is found in the Valve Section, grease separation is occurring. This means that the oil is being squeezed from the grease at normal system operating pressure and the grease thickener is being deposited in the divider valve. Cleaning the divider valve will only temporarily solve the problem. Consult your lubricant supplier for recommendations on alternate lubricants and your local Graco/Trabon distributor to verify compatibility with centralized lubricating systems.

If all indicator port plugs are removed, master will not cycle. Blockage is in this divider valve.(FIG. 11).



# MD Series

## Technical Data

Material	Steel
Pressure (max)	3,000 psi (207 bar)
Lubricant	Oil or grease
Net Weight (approx.)	1-lb. 8 oz (0.68 kg)
Volume (Lubricant to cycle divider valve one complete cycle)	
MD-2, MD-3, MD-4	0.080 in. <sup>3</sup> (1.31 ccm)
MD-6	0.060 in. <sup>3</sup> (0.98 ccm)
Torque Ratings	
Assembly Bolts	8-9 ft. lbs
Enclosure Plugs	11-13 ft. lbs
Indicator Plug	15 ft. lbs
Outlet Plugs	6-7 ft. lbs.

## Parts

Ref	Part No.	Description
1	562656	VALVE, feeder, MD 2
	562657	VALVE, feeder, MD 3
	562658	VALVE, feeder, MD 4
	562659	VALVE, feeder, MD 6
	562653	VALVE, feeder, MD 2, IND
	562654	VALVE, feeder, MD 3, IND
	562655	VALVE, feeder, MD 4, IND
	563270	VALVE, feeder, MD 2, IND/Switch
	563271	VALVE, feeder, MD 3, IND/Switch
	564356	VALVE, feeder, MD 4, IND/Switch

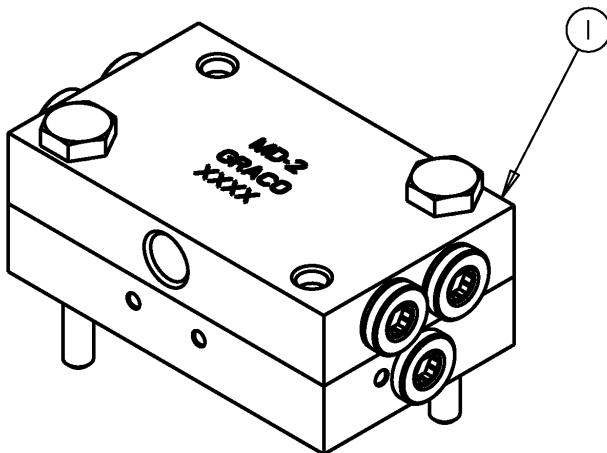

## Dimensions

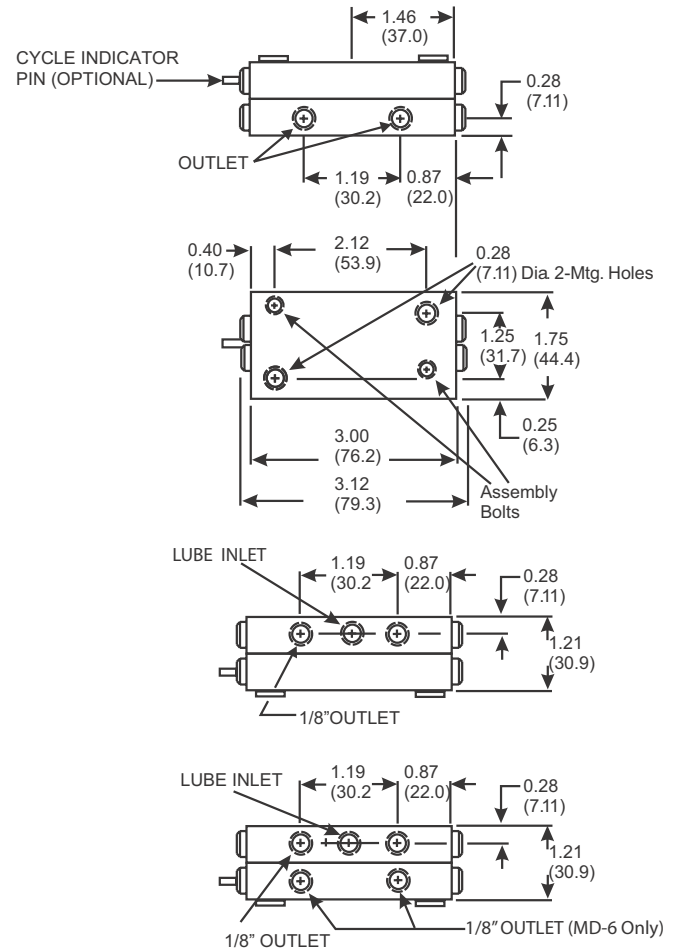

ti11472



**Parts**

Ref	Part No.	Description	
1	562500	VALVE, assembly, MJ 5S	
	562501	VALVE, assembly, MJ 10S	
	562502	VALVE, assembly, MJ 15S	
	562503	VALVE, assembly, MJ 5T	
	562504	VALVE, assembly, MJ 10T	
	562505	VALVE, assembly, MJ 15T	
	562508	VALVE, assembly, IND MJ 10S	
	562512	VALVE, assembly, IND MJ 10S Left	
	562510	VALVE, assembly, IND MJ 10 T	
	562513	VALVE, assembly, IND MJ 10T Left	
	562509	VALVE, assembly, IND MJ 15S	
	562511	VALVE, assembly, IND MJ 15T	
	564205	VALVE, assembly, IND MJ 15T Left	
	562506	VALVE, assembly, SST MJ 5S SST	
	562507	VALVE, assembly, SST MJ 10S SST	
	564203	VALVE, assembly, SST MJ 5T SST	
	564204	VALVE, assembly, SST MJ 10T SST	
	2	560643	INLET, CRS, MJ
		560644	INLET, SST, MJ
3	560645	END, CRS, MJ	
	561405	END, SST, MJ	
4	557515	ROD, tie, MJ 3 (3 required)	
	557516	ROD, tie, MJ 4 (3 required)	
	557517	ROD, tie, MJ 5 (3 required)	
	557518	ROD, tie, MJ 6 (3 required)	
	557519	ROD, tie, MJ 7 (3 required)	
	557520	ROD, tie, MJ 8 (3 required)	
	560649	ROD, tie, MJ 9 (3 required)	
	558917	ROD, tie, MJ 3 SST(3 required)	
	124028	ROD, tie, MJ 4 SST(3 required)	
	124029	ROD, tie, MJ 5 SST (3 required)	
	124030	ROD, tie, MJ 6 SST (3 required)	
	124031	ROD, tie, MJ 7 SST (3 required)	
124032	ROD, tie, MJ 8 SST (3 required)		
124033	ROD, tie, MJ 9 SST (3 required)		
5	556371	NUT, tie rod, 1/4-28 (3 required)	
	558633	NUT, tie rod, 1/4-28 SST (3 required)	

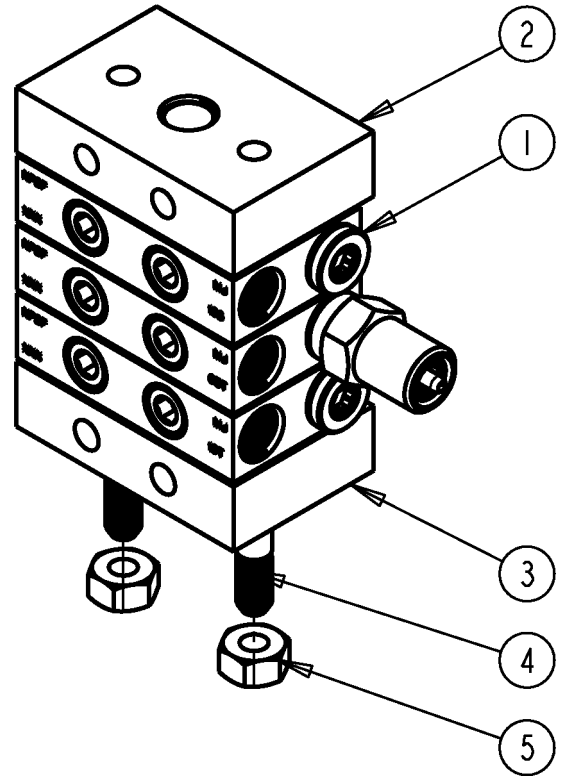

# MSP Series

## Technical Data

Material	Corrosion Protected Steel (optional: Type 316 Stainless Steel)
Pressure (max)	
Zero Leak Inlet	1500 psi (104 bar)
Shunt/Shutoff Inlet	3000 psi (207 bar)
Ambient Temperature (max)	140°F (60°C)
Lubricant	
Zero Leak Inlet	Oil Only - up to 5000 SUS, requires 25 micron (min) filtration
Shunt/Shutoff Inlet	Oil and fluid grease - filter oil through 25 micron filter and grease through 100 micron mesh strainer
New Weight (approx.)	
3 section divider valve assembly	5.9 lbs (2.7 kg)
4 section divider valve assembly	7.3 lbs (3.3 kg)
5 section divider valve assembly	8.7 lbs (4.0 kg)
6 section divider valve assembly	10.2 lbs (4.6 kg)
7 section divider valve assembly	11.6 lbs (5.6 kg)
8 section divider valve assembly	13.0 lbs (5.9 kg)
Torque Ratings	
Mounting Screw	8-9 ft. lbs
Enclosure Plugs	6-8 ft. lbs
Indicator Port Plug	5-7 ft. lbs
Bleed Screws	1-2 ft. lbs.
Tie Rod Nut	5-8 ft. lbs.

# Dimensions

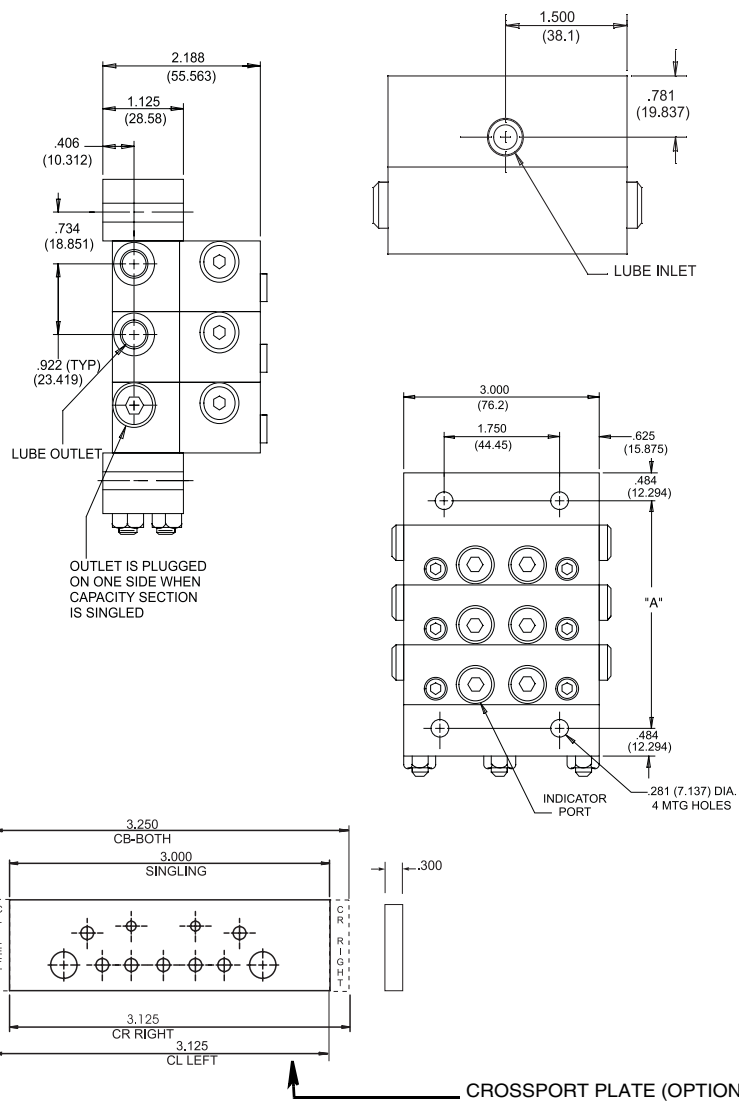

ti11478

## Parts

## Ref Part No. Description

1	562711	VALVE, assembly MSP 05S
	562712	VALVE, assembly MSP 10S
	562713	VALVE, assembly MSP 15S
	562714	VALVE, assembly MSP 20S
	562715	VALVE, assembly MSP 25S
	562716	VALVE, assembly MSP 30S
	562717	VALVE, assembly MSP 35S
	562718	VALVE, assembly MSP 40S
	562720	VALVE, assembly MSP 05T
	562721	VALVE, assembly MSP 10T
	562722	VALVE, assembly MSP 15T
	562723	VALVE, assembly MSP 20T
	562724	VALVE, assembly MSP 25T
	562725	VALVE, assembly MSP 30T
	562726	VALVE, assembly MSP 35T
	562727	VALVE, assembly MSP 40T
	562729	VALVE, assembly IND MSP 20S
	562730	VALVE, assembly IND MSP 25S
	562731	VALVE, assembly IND MSP 30S
	562732	VALVE, assembly IND MSP 35S
	562733	VALVE, assembly IND MSP 40S
	562734	VALVE, assembly IND left MSP 20S
	562735	VALVE, assembly IND left MSP 25S
	562736	VALVE, assembly IND left MSP 30S
	562737	VALVE, assembly IND left MSP 35S
	562738	VALVE, assembly IND left MSP 40S
	562739	VALVE, assembly IND MSP 20T
	562740	VALVE, assembly IND MSP 25T
	562741	VALVE, assembly IND MSP 30T
	562742	VALVE, assembly IND MSP 35T
	562743	VALVE, assembly IND MSP 40T
	562744	VALVE, assembly IND left MSP 20T
	562745	VALVE, assembly IND left MSP 25T
	562746	VALVE, assembly IND left MSP 30T
	562747	VALVE, assembly IND left MSP 35T
	562748	VALVE, assembly IND left MSP 40T
	24B474	VALVE, single, 303 MSP .005
	562755	VALVE, single, 303 MSP .010
	24B475	VALVE, single, 303 MSP .015
	562756	VALVE, single, 303 MSP .020
	24B476	VALVE, single, 303 MSP .025
	24B477	VALVE, single, 303 MSP .030
	24B478	VALVE, single, 303 MSP .035
	562757	VALVE, single, 303 MSP .040
	24B479	VALVE, twin, 303 MSP .005
	562758	VALVE, twin, 303 MSP .010
	24B480	VALVE, twin, 303 MSP .015
	562759	VALVE, twin, 303 MSP .020
	24B481	VALVE, twin, 303 MSP .025
	24B482	VALVE, twin, 303 MSP .030
	24B483	VALVE, twin, 303 MSP .035
	562760	VALVE, twin, 303 MSP .040
	24B484	VALVE, single, 303 MSP .020 w/indicator
	24B485	VALVE, single, 303 MSP .025 w/indicator
	24B486	VALVE, single, 303 MSP .030 w/indicator
	24B487	VALVE, single, 303 MSP .035 w/indicator

## Ref Part No. Description

	24B488	VALVE, single, 303 MSP .040 w/indicator
	24B489	VALVE, twin, 303 MSP .020 w/indicator
	24B490	VALVE, twin, 303 MSP .025 w/indicator
	24B491	VALVE, twin, 303 MSP .030 w/indicator
	24B492	VALVE, twin, 303 MSP .035 w/indicator
	24B493	VALVE, twin, 303 MSP .040 w/indicator
2	24B497	BLOCK, base, 303 MSP
	563425	BLOCK, base, MSP NPSF
	563447	BLOCK, base, MSP, BSPP
	563451	BLOCK, base, MSP, SAE
	563479	BLOCK, base, MSP w/No outlets
3	560919	BLOCK, inlet, MSP, NPSF
	560936	BLOCK, inlet, MSP, BSPP
	560943	BLOCK, inlet, MSP, SAE
	560976	BLOCK, inlet, MSP, ISO 6149
	563421	BLOCK, inlet, MSP, NPSF, w/bleed
	563422	BLOCK, inlet, MSP SAE w/bleed
4	563279	BLOCK, MSP end w/alt inlet
	563424	BLOCK, end, MSP
5	563469	KIT, crossport bar, right
	563470	KIT, crossport bar, left
	563471	KIT, crossport bar, both
6	563472	KIT, singling bar
7	562660	VALVE, assembly bypass, standard MSP
8	557731	ROD, tie, 3 section, MSP (3 required)
	557732	ROD, tie, 4 section, MSP (3 required)
	557733	ROD, tie, 5 section, MSP (3 required)
	557734	ROD, tie, 6 section, MSP (3 required)
	557735	ROD, tie, 7 section, MSP (3 required)
	557736	ROD, tie, 8 section, MSP (3 required)
	557738	ROD, tie, 9 section, MSP (3 required)
	557739	ROD, tie, 10 section, MSP (3 required)
	557740	ROD, tie, 11 section, MSP (3 required)
9	556371	NUT, 1/4 - 28 (3 required)

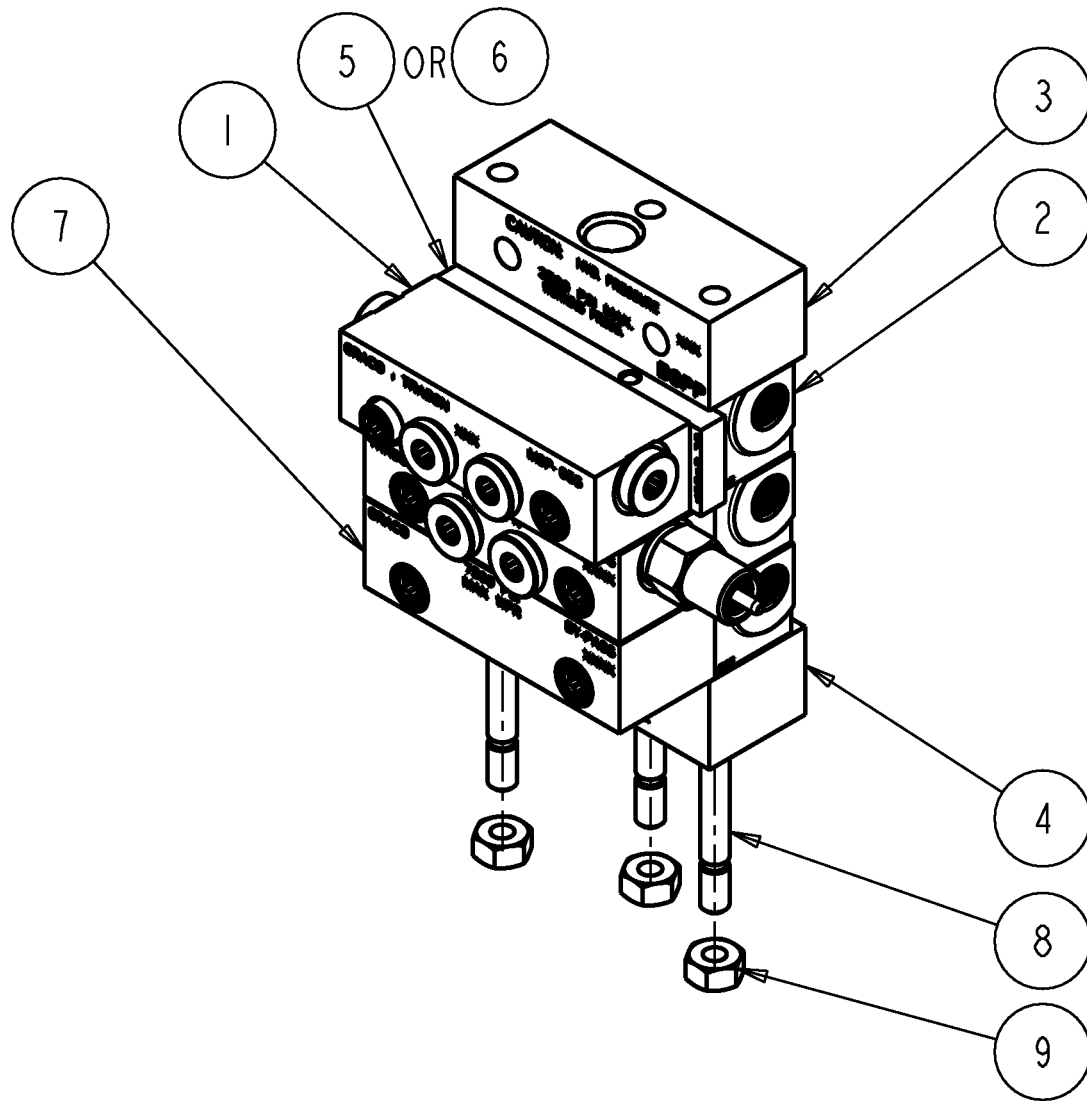

# MHH Series

## Technical Data

Material	Steel Body (corrosion protected) Steel Piston (honed fit)
Pressure (max)	6,000 psi (414 bar) for Petroleum Oil only - Buna O-rings 7,500 psi (517 bar) for Petroleum or Synthetic Oil - fluoroelastomer O-rings
Lubricant	Petroleum or synthetic oil only
Maximum Operating Temperature	
Buna-N O-rings (422-010-060)	200°F (93°C)
Fluoroelastomer O-rings (527-000-840)	350°F (163°C)
Maximum Cycle Rate Without Cycle Pin	200 CPM
Net Weight (approx.)	
3 section divider valve assembly	5.9 lbs (2.7 kg)
4 section divider valve assembly	7.3 lbs (3.3 kg)
5 section divider valve assembly	8.7 lbs (4.0 kg)
6 section divider valve assembly	10.2 lbs (4.6 kg)
7 section divider valve assembly	11.6 lbs (5.6 kg)
8 section divider valve assembly	13.0 lbs (5.9 kg)
Torque Ratings	
Mounting Screw	8-9 ft. lbs
Enclosure Plugs	6-8 ft. lbs
Indicator Port Plug	5-7 ft. lbs
Bleed Screws	1-2 ft. lbs.
Tie Rod Nut	5-8 ft. lbs



## Dimensions

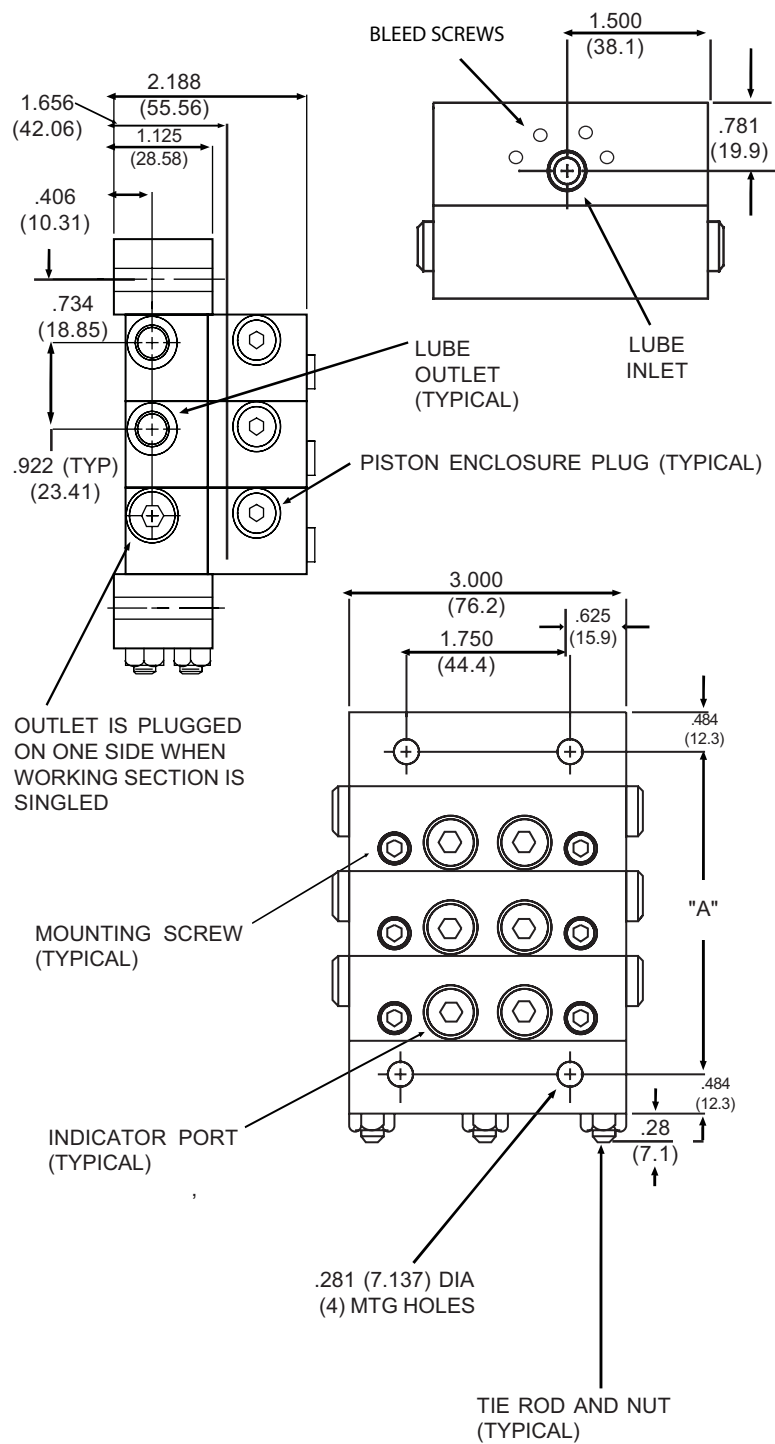

ti11480

**Parts**

Ref	Part No.	Description	Ref	Part No.	Description
1	562679	VALVE, assembly MHH 06S		563422	BLOCK, inlet, MHH SAE w/bleed
	562680	VALVE, assembly MHH 09S		563451	BLOCK, base, MHH, SAE
	562681	VALVE, assembly MHH 12S			
	562682	VALVE, assembly MHH 18S	4	563279	BLOCK, MHH end w/alt inlet
	562683	VALVE, assembly MHH 24S		563424	BLOCK, end, MHH
	562684	VALVE, assembly MHH 30S	5	563469	KIT, crossport bar, right
	562685	VALVE, assembly MHH 06T		563470	KIT, crossport bar, left
	562686	VALVE, assembly MHH 09T		563471	KIT, crossport bar, both
	562687	VALVE, assembly MHH 12T	6	563472	KIT, singling bar
	562688	VALVE, assembly MHH 18T	7	562660	VALVE, assembly bypass
	562689	VALVE, assembly MHH 24T	8	557731	ROD, tie, 3 section (3 required)
	562690	VALVE, assembly MHH 30T		557732	ROD, tie, 4 section (3 required)
2	563425	BLOCK, base, MHH, NPSF		557733	ROD, tie, 5 section (3 required)
	563447	BLOCK, base, MHH, BSPP		557734	ROD, tie, 6 section (3 required)
	563451	BLOCK, base, MHH, SAE		557735	ROD, tie, 7 section, (3 required)
	563479	BLOCK, base, MHH w/no outlets		557736	ROD, tie, 8 section (3 required)
3	560919	BLOCK, inlet, MHH, NPSF		557738	ROD, tie, 9 section (3 required)
	560936	BLOCK, inlet, MHH, BSPP		557739	ROD, tie, 10 section (3 required)
	560943	BLOCK, inlet, MHH, SAE		557740	ROD, tie, 11 section (3 required)
	560976	BLOCK, inlet, MHH, ISO 6149	9	556371	NUT, 1/4 - 28 (3 required)
	563421	BLOCK, inlet, MHH, NPSF, w/bleed			

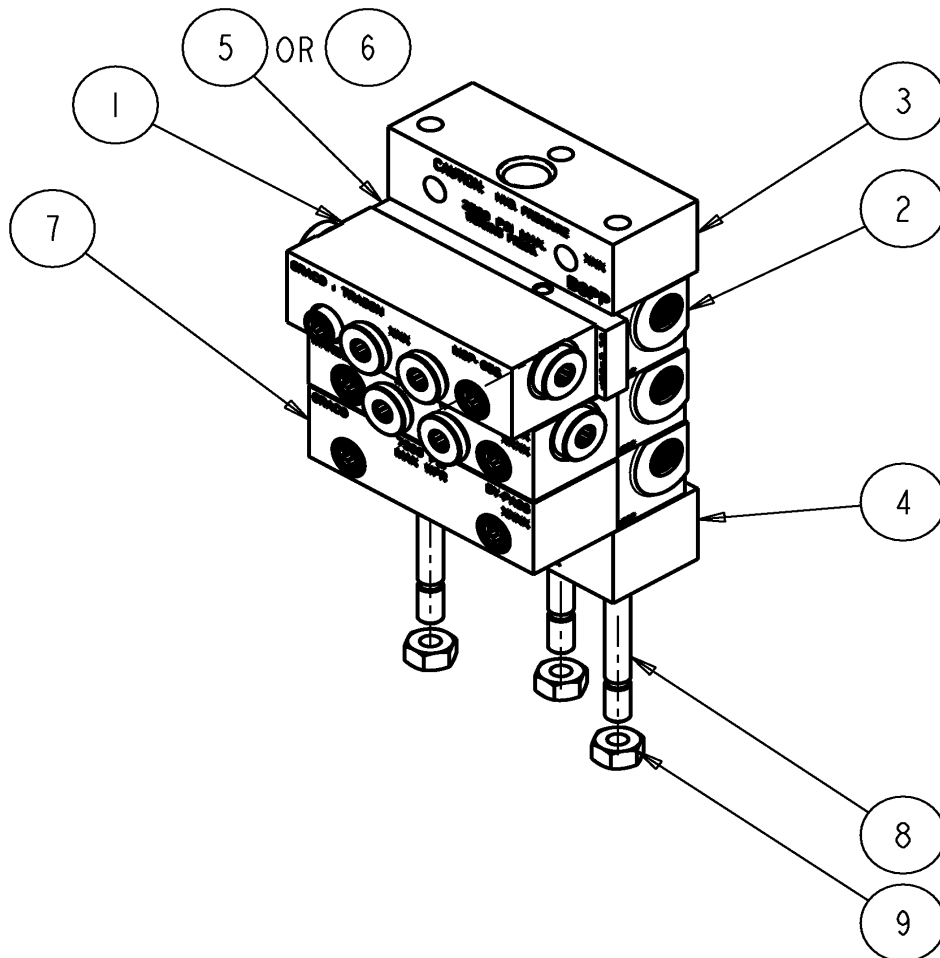

# MXP Series

## Technical Data

Material	Zinc Plated Steel
Pressure (max)	3,000 psi (207 bar)
Lubricant	Oil or grease
Maximum Operating Temperature	350°F (177°C)
Maximum Cycle Rate With Cycle Pin	60 CPM
Maximum Cycle Rate Without Cycle Pin or With Prox Cycle Switch	200 CPM
Net Weight (approx.)	
3 section divider valve assembly	18-lb. 2 oz (8.3 kg)
4 section divider valve assembly	22 lbs. 6 oz (10.2 kg)
5 section divider valve assembly	26 lbs. 9 oz (12.2 kg)
6 section divider valve assembly	31 lbs. 3 oz (14.2 kg)
7 section divider valve assembly	35 lbs. 6 oz (16.2 kg)
8 section divider valve assembly	39 lbs. 9 oz (18.1 kg)
9 section divider valve assembly	44 lbs. 3 oz (20.1 kg)
10 section divider valve assembly	48 lbs. 6 oz (22.1 kg)
Torque Ratings	
Tie Rod Nut	6-9 ft. lbs
Enclosure Plugs	48 +/- 2 ft. lbs
Indicator Plug	12 -15 ft. lbs
Valve Section Mounting Screw	12-13 ft. lbs.

## Dimensions

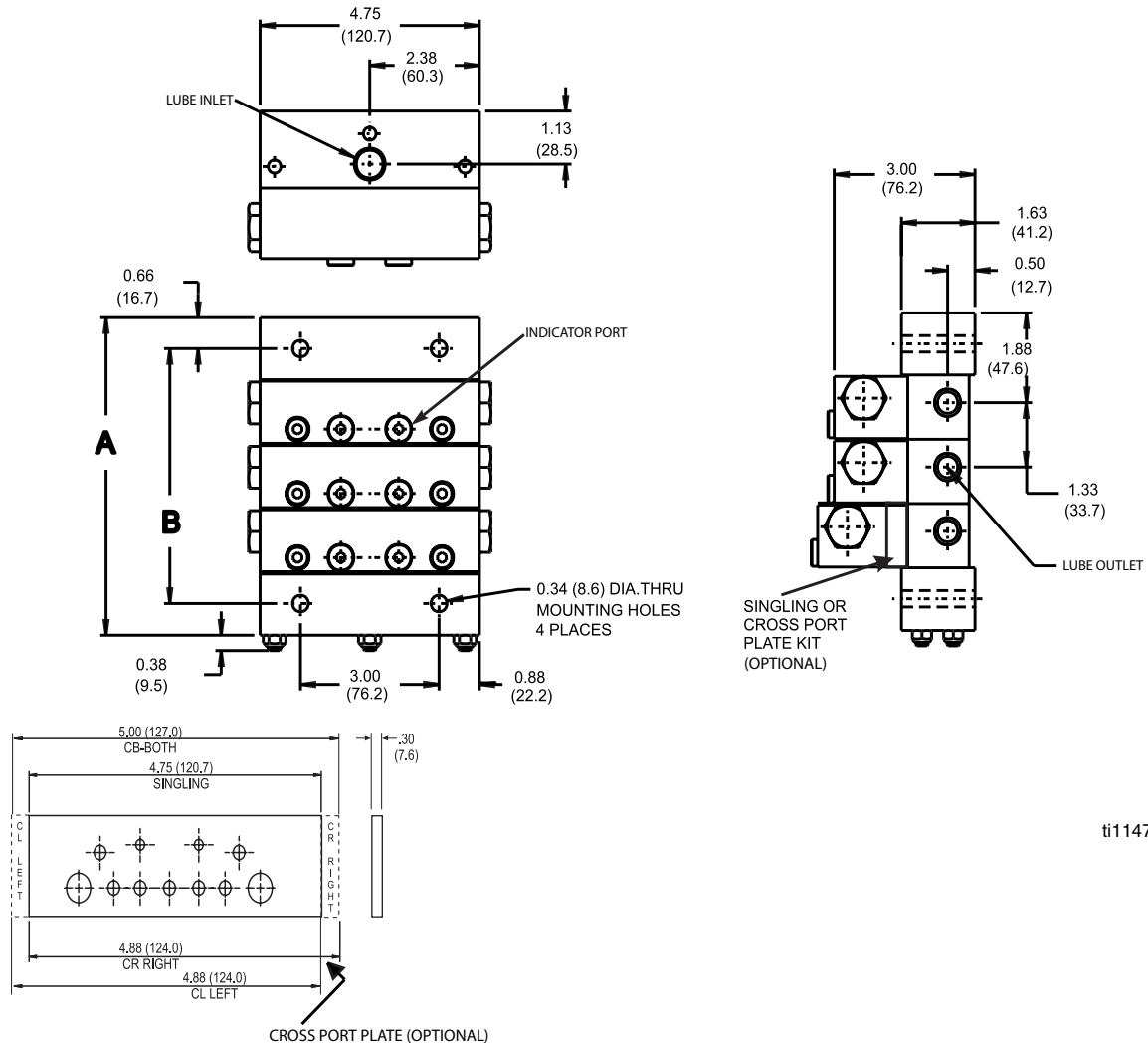

ti11477

## Parts

### Ref Part No. Description

1	562813	VALVE, twin, .025 MXP
	562814	VALVE, twin, .050 MXP
	562815	VALVE, twin, .075 MXP
	562816	VALVE, twin, .100 MXP
	562817	VALVE, twin, .125 MXP
	562818	VALVE, twin, .150 MXP
	562819	VALVE, single, .025 MXP
	562820	VALVE, single, .050 MXP
	562821	VALVE, single, .075 MXP
	562822	VALVE, single, .100 MXP
	562823	VALVE, single, .125 MXP
	562824	VALVE, single, .150 MXP
	562825	VALVE, twin, .050 MXP w/indicator
	562826	VALVE, twin, .075 MXP w/indicator
	562827	VALVE, twin, .100 MXP w/indicator
	562828	VALVE, twin, .125 MXP w/indicator
	562829	VALVE, twin, .150 MXP w/indicator
	562830	VALVE, single, .050 MXP w/indicator
	562831	VALVE, single, .075 MXP w/indicator
	562832	VALVE, single, .100 MXP w/indicator
	562833	VALVE, single, .125 MXP w/indicator

### Ref Part No. Description

	562834	VALVE, single, .150 MXP w/indicator
2	563519	BLOCK, BSPLT interm MXP 1/4 NPSF
	563521	BLOCK, BSPLT interm MXP SAE
	563522	BLOCK, BSPLT interm MXP 1/4 BSPP
	563479	BLOCK, base, MSP/MHH w/no outlets
3	56R994	BLOCK, inlet, MXP
4	563518	BLOCK, end, machine MX
5	563524	KIT, MXP, crossport bar, left
	563525	KIT, MXP, crossport bar, right
	563526	KIT, MXP, crossport bar, both
6	15R997	BLOCK, bypass, MXP
7	557766	ROD, tie, 3 section, MXP (3 required)
	557767	ROD, tie, 4 section, MXP (3 required)
	557768	ROD, tie, 5 section, MXP (3 required)
	557769	ROD, tie, 6 section, MXP (3 required)
	557770	ROD, tie, 7 section, MXP (3 required)
	557771	ROD, tie, 8 section, MXP (3 required)
	557772	ROD, tie, 9 section, MXP (3 required)
	563520	ROD, tie, 10 section, MXP (3 required)
8	555406	NUT, 5/16 - 24 light hex (3 required)

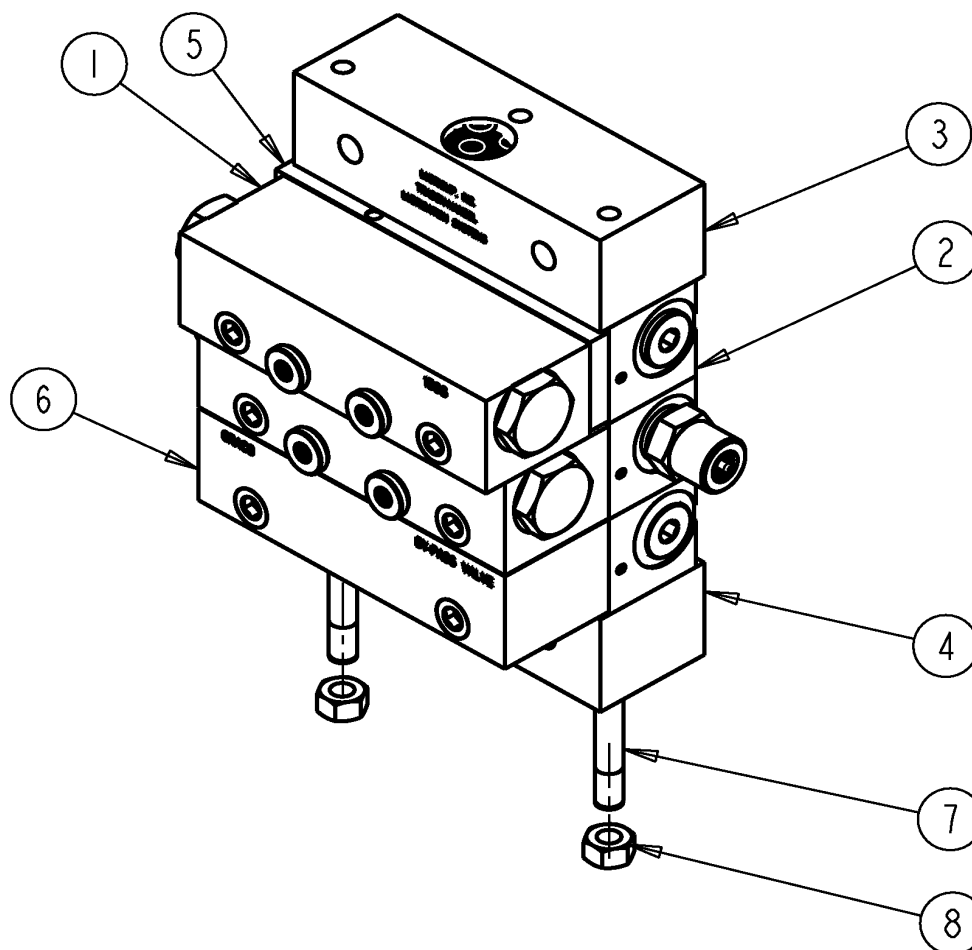

# MGO Series

## Technical Data

Material	Zinc Plated Steel and Phosphate Coated Cast Iron
Pressure (max)	
3-7 section divider valve assembly	6000 psi (414 bar)
8 section divider valve assembly	5500 psi (380 bar)
9 section divider valve assembly	5000 psi (345 bar)
10 section divider valve assembly	4500 psi (311 bar)
11 section divider valve assembly	4000 psi (276 bar)
Lubricant	Oil or grease
Maximum Operating Temperature	200°F (93°C)
Maximum Cycle Rate With Cycle Pin	60 CPM
Maximum Cycle Rate Without Cycle Pin or With Prox Cycle Switch	200 CPM
Net Weight (approx.)	
3 section divider valve assembly	45-lb. (20.41 kg)
4 section divider valve assembly	53 lbs. 5 oz (24.18 kg)
5 section divider valve assembly	61 lbs. 10 oz (27.95 kg)
6 section divider valve assembly	70 lbs. 15 oz (32.17 kg)
7 section divider valve assembly	80 lbs. 4 oz (36.40 kg)
8 section divider valve assembly	89 lbs. 9 oz (40.62 kg)
9 section divider valve assembly	98 lbs. 14 oz (44.84 kg)
10 section divider valve assembly	108 lbs. 3 oz (49.07 kg)
11 section divider valve assembly	117 lbs. 8 oz (53.40 kg)
Torque Ratings	
Tie Rod Nut	12 ft. lbs
Enclosure Plug	15 ft. lbs
Outlet Port Plug	6-8 ft. lbs
Valve Section Mounting Screw	12-13 ft. lbs.

## Dimensions

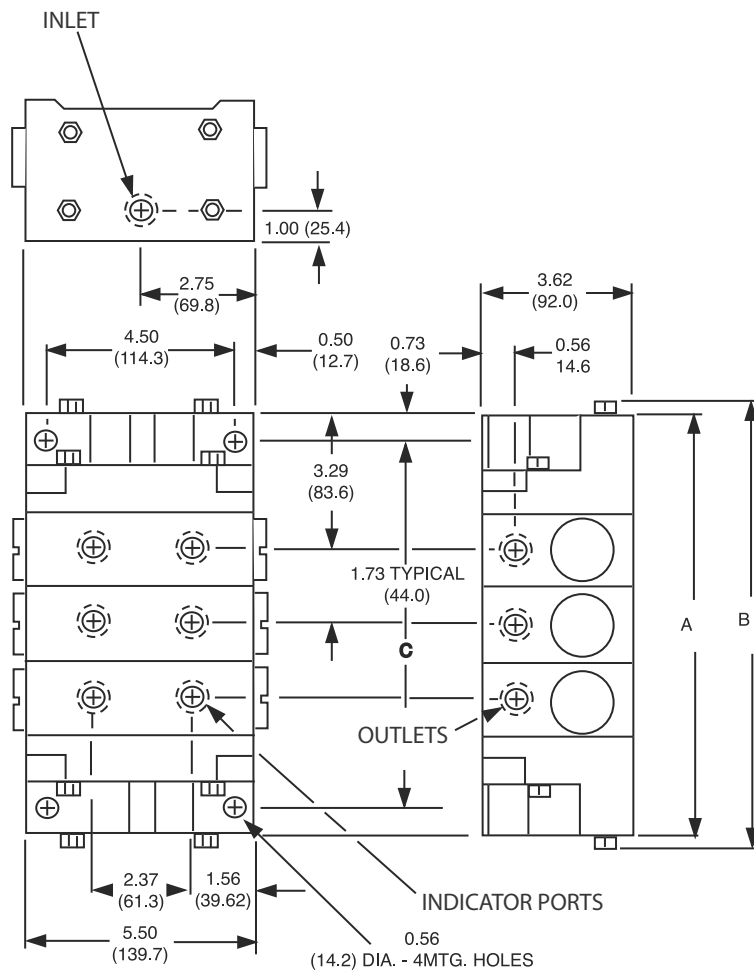

Parts

Ref Part No. Description

- 1 562570 VALVE, MGO, assembly 150S SAE
- 562571 VALVE, MGO, assembly 300S SAE
- 562572 VALVE, MGO, assembly 450S SAE
- 562573 VALVE, MGO, assembly 600S SAE
- 562574 VALVE, MGO, assembly 150T SAE
- 562575 VALVE, MGO, assembly 300TS SAE
- 562576 VALVE, MGO, assembly 450T SAE
- 562577 VALVE, MGO, assembly 600T SAE
- 562578 VALVE, MGO, assembly 150S SAE IND
- 562579 VALVE, MGO, assembly 300S SAE IND
- 562580 VALVE, MGO, assembly 450S SAE IND
- 562581 VALVE, MGO, assembly 600S SAE IND
- 562582 VALVE, MGO, assembly 150T SAE IND
- 562583 VALVE, MGO, assembly 300T SAE IND
- 562584 VALVE, MGO, assembly 450T SAE IND
- 562585 VALVE, MGO, assembly 600T SAE IND
- 2 563277 INLET,
- 3 563278 END
- 4 560591 ROD, tie, short MGO 3 (2 required)
- 560592 ROD, tie, short MGO 4 (2 required)
- 560593 ROD, tie, short MGO 5 (2 required)
- 560594 ROD, tie, short MGO 6 (2 required)
- 560595 ROD, tie, short MGO 7 (2 required)
- 560596 ROD, tie, short MGO 8 (2 required)
- 560597 ROD, tie, short MGO 9 (2 required)
- 560598 ROD, tie, short MGO 10 (2 required)
- 560599 ROD, tie, short MGO 11 (2 required)
- 5 560600 ROD, tie, long MGO 3 (2 required)
- 560601 ROD, tie, long MGO 4 (2 required)
- 560602 ROD, tie, long MGO 5 (2 required)
- 560603 ROD, tie, long MGO 6 (2 required)
- 15U857 ROD, tie, long MGO 7 (2 required)
- 560604 ROD, tie, long MGO 8 (2 required)
- 560605 ROD, tie, long MGO 9 (2 required)
- 560606 ROD, tie, long MGO 10 (2 required)
- 560607 ROD, tie, long MGO 11 (2 required)
- 6 555406 NUT, tie rod 3/8 - 24 lock (8 required)

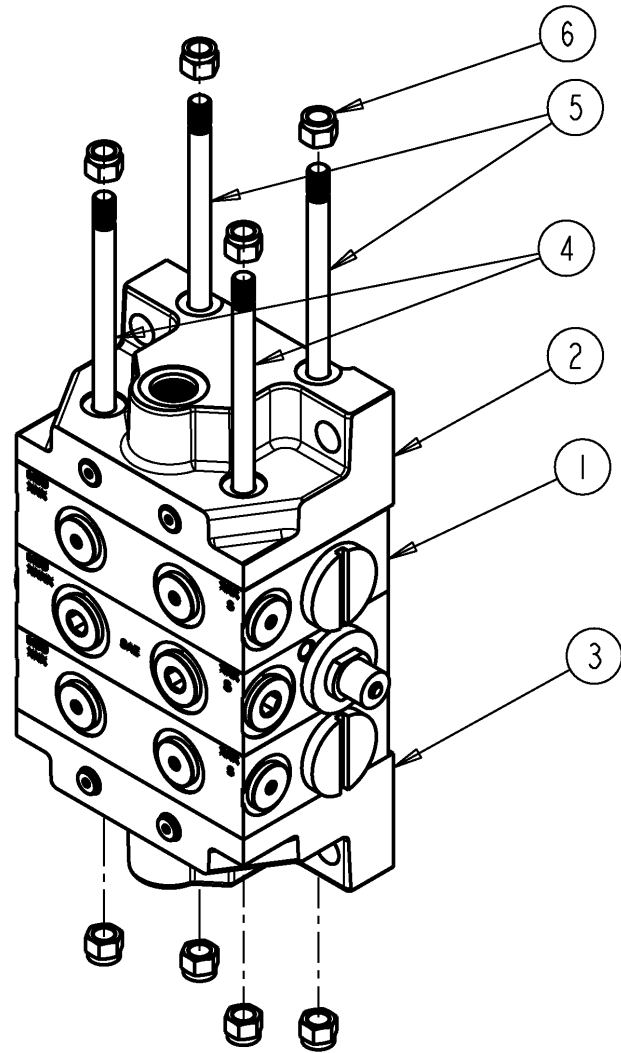



# MX Series

## Technical Data

Material	Plated Steel
Pressure (max)	3,000 psi (207 bar)
Lubricant	Oil or grease
Maximum Operating Temperature	200°F (93°C)
Maximum Cycle Rate With Cycle Pin	60 CPM
Maximum Cycle Rate Without Cycle Pin	200 CPM
Net Weight (approx.)	
3 section divider valve assembly	21-lb. 6 oz (9.69 kg)
4 section divider valve assembly	25 lbs. 10 oz (11.62 kg)
5 section divider valve assembly	29 lbs. 14 oz (13.55 kg)
6 section divider valve assembly	34 lbs. 2 oz (15.47 kg)
7 section divider valve assembly	38 lbs. 6 oz (17.40 kg)
8 section divider valve assembly	42 lbs. 12 oz (19.39 kg)
9 section divider valve assembly	47 lbs. 2 oz (21.37 kg)
10 section divider valve assembly	51 lbs. 8 oz (23.26 kg)
Torque Ratings	
Tie Rod Nut	30 ft. lbs
Enclosure Plug	48 ft. lbs
Outlet Port Plugs	18 ft. lbs.

## Dimensions

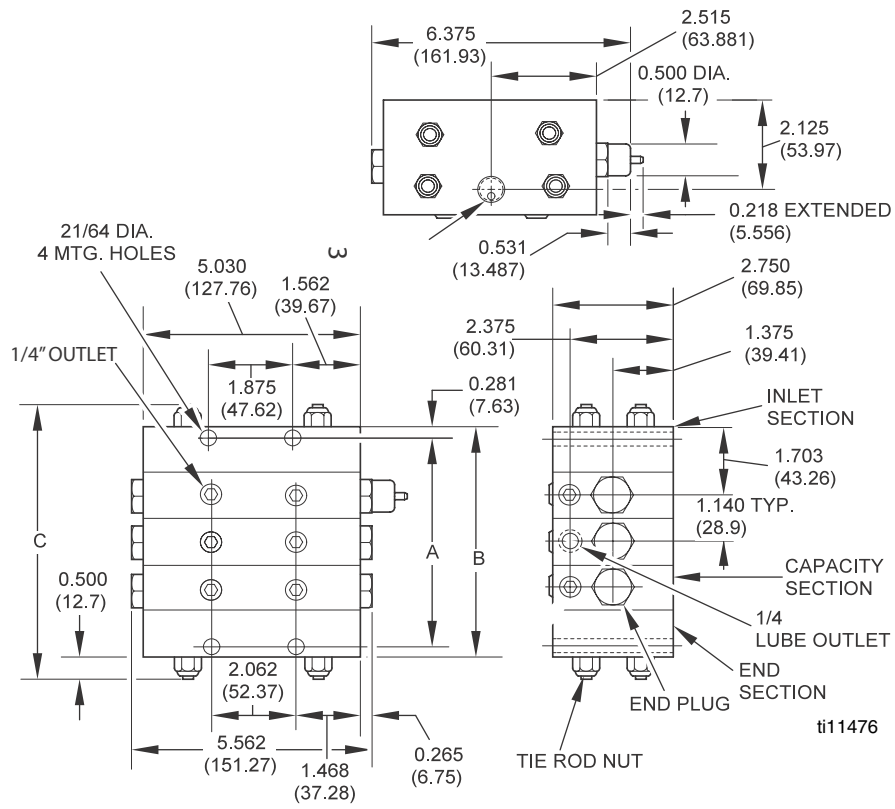

## Parts

### Ref Part No. Description

1	562514	VALVE, MX assembly 25S
	562515	VALVE, MX assembly 25T
	562516	VALVE, MX assembly 50S
	562517	VALVE, MX assembly 50T
	562538	VALVE, MX assembly 75S
	562539	VALVE, MX assembly 75T
	562540	VALVE, MX assembly 100S
	562541	VALVE, MX assembly 100T
	562542	VALVE, MX assembly 125S
	562543	VALVE, MX assembly 125T
	562545	VALVE, MX assembly 150S
	562546	VALVE, MX assembly 150T
	562528	VALVE, MX assembly 50S IND LH
	562518	VALVE, MX assembly 50S IND RH
	562533	VALVE, MX assembly 50T IND LH
	562523	VALVE, MX assembly 50T IND RH
	562529	VALVE, MX assembly 75S IND LH
	562519	VALVE, MX assembly 75S IND RH
	562534	VALVE, MX assembly 75T IND LH
	562524	VALVE, MX assembly 75T IND RH
	562530	VALVE, MX assembly 100S IND LH
	562520	VALVE, MX assembly 100S IND RH
	562569	VALVE, MX assembly 100T IND LH
	562525	VALVE, MX assembly 100T IND RH
	562531	VALVE, MX assembly 125S IND LH
	562521	VALVE, MX assembly 125S IND RH
	562535	VALVE, MX assembly 125T IND LH
	562526	VALVE, MX assembly 125T IND RH
	562532	VALVE, MX assembly 150S IND LH
	562522	VALVE, MX assembly 150S IND RH
	562536	VALVE, MX assembly 150T IND LH
	562527	VALVE, MX assembly 150T IND RH
2	560620	BLOCK, inlet
3	563287	BLOCK, end
4	557488	ROD, tie, MX 3 (4 required)
	557489	ROD, tie, MX 4 (4 required)
	557490	ROD, tie, MX 5 (4 required)
	557491	ROD, tie, MX 6 (4 required)
	557492	ROD, MX 7 (4 required)
	557493	ROD, tie, MX 8 (4 required)
	560576	ROD, tie, MX 9 (4 required)
	560577	ROD, tie, MX 10 (4 required)
5	557494	NUT, tie rod 3/8 - 24 lock (8 required)

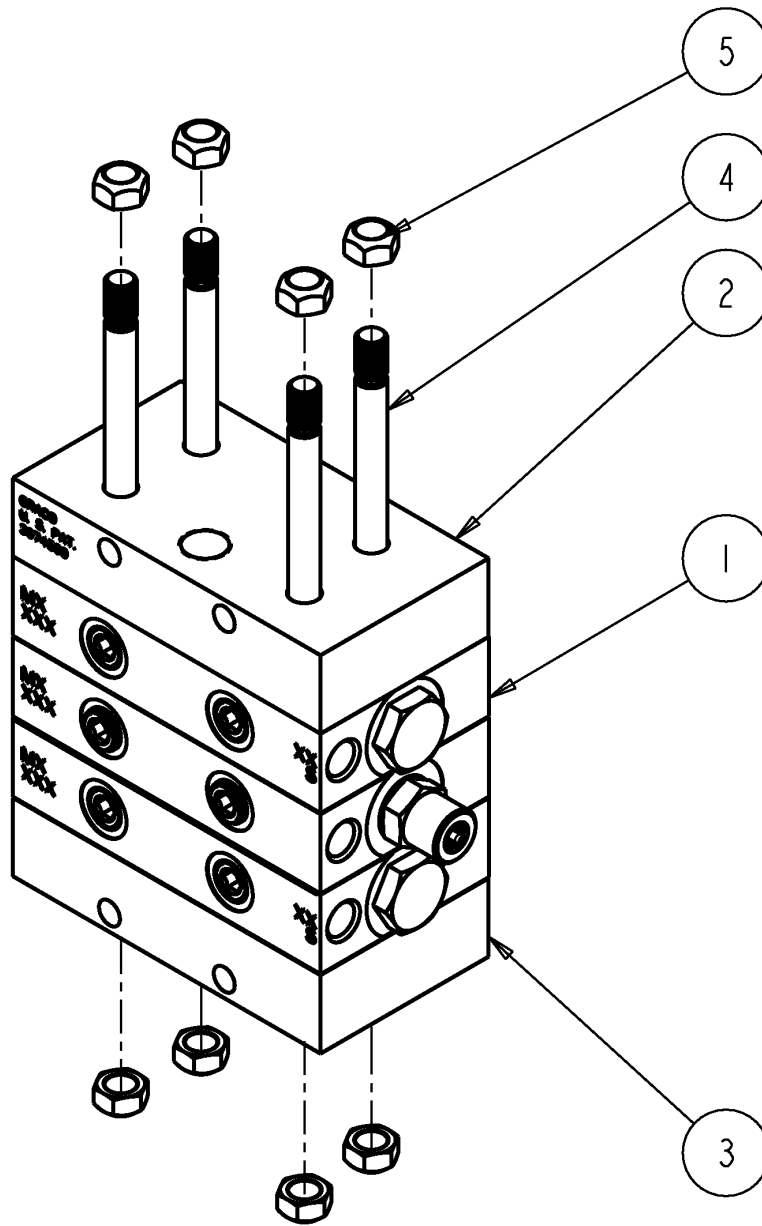

## Accessories

### Tube Clips

Clips are plated and provided with 17/64" (6.75 mm) mounting holes.

Part No.	Description
557324	Holds 1 - 1/4" (6.35 mm) OD tube
558711	Holds 1 - 3/8" (9.52 mm) OD tube
558710	Holds 3 - 1/4" (6.35 mm) OD tube

### Mounting Bars

Part No.	Description
560920	MSP, 1/2" (12.7 mm) thick, 1/4-20 thread
561101	MJ, 1/2" (12.7 mm) thick, 10-24 thread
561102	MX and MXP, 1/2" (12.7 mm) thick, 5/16-18 threads, two sets of mounting holes
563465	KIT, mounting bar, includes 2 mounting bars, 4 screws, washers and lock washers

### Mounting Brackets

All mounting brackets include screws, lock washers and nuts.

Part No.	Description
563435	MSP and MH, M-3 and M-4, 1/8" (3.175 mm) thick, top mounting.
563436	MSP and MH, M5 and M-6, 1/8" (3.175 mm) thick, top mounting
563437	MSP and MH, M7 and M-8, 1/8" (3.175 mm) thick, top mounting
563438	MSP and MH, M-3 and M-4, 1/8" (3.175 mm) thick, side mounting.
563439	MSP and MH, M5 and M-6, 1/8" (3.175 mm) thick, side mounting
563440	MSP and MH, M7 and M-8, 1/8" (3.175 mm) thick, side mounting

## Performance Indicators

Performance indicators are pressure sensitive devices that signals a fault when there is excessive build up of pressure in a series progressive lubricating system. A fault is identified by either causing a pin to protrude or by releasing lubricant to the atmosphere.

### Reset Indicator with Memory

Reset Indicators stop lube system operation when a fault occurs. They can be used in either master or secondary divider valves. Fault is indicated when a pin protrudes through the opening in the cap and is manually reset.

Pressure PSI	Description				
	1/8" NPTF MJ, MH, MS, MXP	1/8" NPSF w/O-Ring MH, MS, MXP	Nickel Plated 1/8" NPTF MJ, MH, MS, MXP	1/4" NPTF MX Only	7/8" SAE w/O-Ring MGO
250	563231	563252	NA	563239	NA
500	563232	563253	563246	563240	NA
750	563233	563254	NA	563241	NA
1000	563234	563255	563247	563242	NA
1500	563235	563256	563248	563243	564200
2000	563236	563257	NA	563244	NA
2500	563237	563258	563249	563245	NA
3000	NA	563261	NA	NA	NA
5000	NA	563262	NA	NA	NA

## Automatic Relief Indicator

Automatic Relief Indicators pinpoint lube line blockage but allow the lube system to continue to supply lubrication to points that are not blocked. They are used primarily in secondary divider valves. When needed, pressure is relieved through a vent. When pressure is relieved the spring resets the piston. Because these indicators permit the lube system to continue operating when a lube point is blocked, a separate pressure switch connected to an audible or visual alarm should be used to warn of high pressure.

Pressure PSI	Color*	Description		
		1/8" NPTF MJ, MH, MS, MXP	1/8" NPSF w/O-Ring MH, MS, MXP	1/4" NPTF MX Only
750 ± 20%	Blue	563163	563170	563156
1000 ± 20%	Green	563164	563171	563157
1250 ± 20%	Yellow	563165	563172	NA
1500 ± 20%	Red	563166	563173	563158
2000 ± 20%	Orange	563167	563174	563159
2500 ± 20%	Aluminum	563168	563175	563160
3000 ± 24%	Purple	563169	563176	563161

\* Color provided for reference only to aid in selection of replacement indicator. Indicators used to be identified by the color of the spring retainer located in the end of the indicator.

## Rupture Indicator - MH Divider Valves Only

Rupture Indicators are only used on MH divider valve applications where lube system pressures exceed 2500 psi. The high pressure from a lube line blockage causes a disc to rupture. The lubricant then forces an indicator pin to protrude, locating the blockage. The high pressure backs up through the system and trips a switch to shut the system off. When the fault is corrected, the disc must be replaced the pin reset manually.

Pressure PSI	Description			
	1/8" - 27 NPTF	1/8" - 27 NPSF w/O-Ring	Disc Color	Replacement Disc 3/8" Diameter
2800 ± 20%	563228	563229	Green	557422
3700 ± 20%	563220	563221	Yellow	557423
4600 ± 20%	564355	563222	Red	557424
5500 ± 20%	563223	563224	Orange	557425
6400 ± 20%	563225	563226	Pink	557427
7300 ± 20%	563227	NA	Blue	557428
8200 ± 20%	NA	NA	Purple	557429

## Rupture-to-Atmosphere Indicator

Rupture-to-Atmosphere Indicators are standard on all Graco pumps. When the pressure reaches a predetermined pressure setting, the pressure disc ruptures, venting lubricant into the atmosphere and relieving pressure.

Pressure PSI*	Description			
	Complete Assembly	Replacement	Disc Color	Blowout Disc
	<b>1/4" NPTF Fittings</b>	<b>11/16" Diameter</b>		<b>Quantity = 6</b>
<b>900</b>	NA	557431	Black	NA
<b>1450</b>	563179	557433	Yellow	563962
<b>1750</b>	563182	557434	Red	563963
<b>2050</b>	563183	557435	Orange	563964
<b>2350</b>	563184	557436	Aluminum	563965
<b>2650</b>	NA	557467	Pink	NA
<b>2950</b>	563185	557438	Blue	563966
<b>3250</b>	NA	557439	Purple	NA
	<b>1/8" NPTF Fittings</b>	<b>3/8" Diameter</b>		<b>Quantity = 25</b>
<b>900</b>	NA	555788	Black	563952
<b>1450</b>	NA	557423	Yellow	563954
<b>1750</b>	564059	557424	Red	563955
<b>2050</b>	NA	557425	Orange	563956
<b>2350</b>	563191	557426	Aluminum	563957
<b>2650</b>	NA	557427	Pink	563958
<b>2950</b>	563192	557428	Blue	563959
<b>3250</b>	563193	557429	Purple	563960
<b>5000</b>	563194	557430	Brown	563961
	<b>High Pressure 1/8" NPTF Fittings</b>	<b>3/8" Diameter</b>		<b>Quantity = 25</b>
<b>3700</b>	564479	557423	Yellow	563954
<b>4600</b>	563216	557424	Red	563955
<b>5500</b>	563217	557425	Orange	563956
<b>6400</b>	563218	557427	Pink	563958
<b>7300</b>	563219	557428	Blue	563959
<b>8200</b>	NA	557429	Purple	563960
<b>9500</b>	NA	NA	Gray	NA

## Rupture-to-Atmosphere Indicator with Spud Assembly

A Spud Assembly is available to return vented lubricant to the reservoir by way of a tube. A high pressure switch is recommended to provide an audible or visual warning alarm that height system pressure has occurred.

Pressure PSI*	Description		
	Complete Assembly	Replacement	Disc Color
<b>1450</b>	563186	557433	Yellow
<b>1750</b>	563187	557434	Red
<b>2350</b>	563188	557436	Aluminum

\*All pressures have a tolerance of + 500 psi.

## Rupture Discs

All discs are 11/16" diameter.

Pressure PSI*	Description		Quantity 6/package
	Single Disc	Disc Color	
900	557431	Black	NA
1175	557432	Green	NA
1450	557433	Yellow	563962
1750	557434	Red	563963
2050	557435	Orange	563964
2350	557436	Aluminum	563965
2650	557437	Pink	NA
2950	557438	Blue	563966
3250	557439	Purple	NA

\*All pressures have a tolerance of + 500 psi.

## Singling and Crossporting Bar Assemblies

Singling Kits externally convert a "T" (Twin Outlet) section to an "S" (Single Outlet) section.

Crossporting Kits externally combine the output of two (2) adjacent sections.

Part Numbers								
Divider	Single Kit	Right Side	Left Side	O-Ring	Gasket Upper Seal (Bar Type)	Gasket Lower Seal (Bar Type)	90 Duro Fluoroelastomer O-Ring (plate Type)	Valve Block Mounting Screw-Long
MJ	562915	562914	562914	NA	557359	557403	NA	NA
MJ-SS	NA	NA	NA	NA	NA	NA	NA	NA
MSP	563469	563469	563470	563471	NA	NA	557722	556514
MS (Nickel)	NA	NA	NA	NA	NA	NA	NA	NA
MX	52916	52917	52917	NA	55711	55712	NA	NA
MXP	NA	563525	563524	56e526	NA	NA	557773	555601
MXP (Nickel)	NA	NA	NA	NA	NA	NA	NA	NA
MGO	NA	NA	NA	NA	NA	NA	NA	NA

## Cycle Indicators

Cycle Indicators provide a means of visually monitoring lube flow thru the system.

The pin type cycles in and out when lubricant is flowing. Movement of the pin is caused by the piston (the two are attached) so that when the piston moves the indicator pin in and out once, the entire divider valve has cycled.

Valve Series	O-Ring Sealed
MS/MH	563251
MX/MXP	563260
MGO	NA



## Cycle Counters - Part No.: 563444

The purpose of a cycle counter is to give assurance that the lubricant is flowing thru the system. Every "count" indicates one complete cycle of the divider valve. Visual inspection and/or recording of counts provides a constant check on the performance of your lubricant system and the pump. The Cycle Counter can be used on any MJ, MS, MH, MX and MXP divider valve assembly.

## Cycle Switches

The function of a Cycle Switch is to electrically give assurance that the lubricant is flowing through the system. Actuated by a cycle pin, the switch can be wired to various controls.

NOTE: The cycle switch MUST be attached to a section that is equipped with a cycle indicator pin.

Part Numbers						
Series Flo Divider Valves	MJ	MS/MH	MS (Nickel)	MX	MXP	MGO
Cycle Switch and Bracket Assembly SPDT	563272	563272	563272	563272	563272	563269
Replacement Switch	557781	557781	557781	557781	557781	557781
Cycle Switch and Bracket Assembly DPDT	564357	564357	564537	564357	564537	NA
Replacement Switch	NA	NA	NA	NA	NA	NA
Replacement Bracket for either SPDT or DPDT Switch Assembly	557546	557546	557546	557546	557546	560573
Moisture Resistant Cycle Switch with 6-foot Cable and Bracket Assembly SPDT	563273	563273	563273	563273	563273	NA
Replacement Switch with 6-foot Cable	557782	557782	557782	557782	557782	NA

## Proximity Cycle Switches

The Proximity Cycle Switches are magnetically operated single throw switches that sense the movement of the divider valve piston when it is cycling. Each proximity cycle switch provides a signal that is used to monitor the system. There are 3 different types of switches available.

**Reed Type Proximity Switch:** Can be used with oil applications only for MS, MH and MGO divider valves at pressures up to 518 bar (7500 psi) at cycle rates under 60 cycles per minute.

**Field Sensitive Magnetic Proximity Switch:** Dry contact, ceramic magnet operated switch. Used at pressures that do not exceed 242 bar (3500 psi) at cycle rates up to 200 cycles per minute. Used in MS/MH, MX/MXP and MGO divider valves. An explosion proof version for MS/MH divider valves is available.

**Magnetic Operated Proximity Switch:** Not limited to valve size. Miniature snap-action switch is tripped by attraction of internal magnet to the moving divider piston. Can be used at pressures up to 518 bar (7500 psi) at cycle rates that do not exceed 150 cycles per minute.

Description	No. of Pins	Type Seal	Part Number				
			MS	MH	MX	MXP	MGO
Unattached Reed Type (oil only) 10mA @ 120VAC 24 mA @ 24VDC 10,000,000 Cycle Life	1/2 NPT with Leads (Explosion Proof)	O-Ring	563427	563427	NA	NA	NA
Field Sensitive Magnetic Type 3-pin and 5-pin (AC only) 2A @ 120/240 VAC 4-pin (DC only) 0.1A @ 28VDC 150,000,000 Cycle Life	3	O-Ring	557741	557741	563476	563476	563970
		Gasket*	NA	NA	NA	NA	NA
	5	O-Ring	557746	557746	564399	564399	NA
		Gasket*	NA	NA	NA	NA	NA
	4	O-Ring	557747	557747	558939	558939	563495
Magnetic Type with LED's 5A @ 24 VDC 10,000,000 Cycle Life	3	O-Ring	563478	563478	NA	NA	NA
	5	O-Ring	563477	563477	NA	NA	NA
Magnetic Type 5A @ 24VDC 5A @ 120/240 VAC 10,000,000 Cycle Life	3	Gasket*	NA	NA	563486	563486	NA
	5	O-Ring	563484	563484	564400	564400	NA
	Pigtail Lead (Explosion Proof)	O-Ring	563485	563485	NA	NA	NA
Field Sensitive Magnetic Type 25 mA @ 24VDC M12 x 1, 4-pin (DC only) 10,000,000, cycle life	4	O-Ring	563500	563501	NA	NA	NA

\*Consult your distributor for availability.

## Proximity Switch Connection Cables

Connection Cables for:					
3-Pin Proximity Switch			5-Pin Proximity Switch		
Connector	Length - ft (m)	Part No.	Connector	Length - ft (m)	Part No.
Straight	6 (1.83)	558021	Straight	6 (1.83)	558023
Straight	12 (3.66)	558022	Straight	12 (3.66)	558024
NA	NA	NA	90°	6 (1.83)	558965
4-Pin Proximity Switch					
Straight	7 (2.13)	568738	NA	NA	NA

# Graco Standard Warranty

Graco warrants all equipment referenced in this document which is manufactured by Graco and bearing its name to be free from defects in material and workmanship on the date of sale to the original purchaser for use. With the exception of any special, extended, or limited warranty published by Graco, Graco will, for a period of twelve months from the date of sale, repair or replace any part of the equipment determined by Graco to be defective. This warranty applies only when the equipment is installed, operated and maintained in accordance with Graco's written recommendations.

This warranty does not cover, and Graco shall not be liable for general wear and tear, or any malfunction, damage or wear caused by faulty installation, misapplication, abrasion, corrosion, inadequate or improper maintenance, negligence, accident, tampering, or substitution of non-Graco component parts. Nor shall Graco be liable for malfunction, damage or wear caused by the incompatibility of Graco equipment with structures, accessories, equipment or materials not supplied by Graco, or the improper design, manufacture, installation, operation or maintenance of structures, accessories, equipment or materials not supplied by Graco.

This warranty is conditioned upon the prepaid return of the equipment claimed to be defective to an authorized Graco distributor for verification of the claimed defect. If the claimed defect is verified, Graco will repair or replace free of charge any defective parts. The equipment will be returned to the original purchaser transportation prepaid. If inspection of the equipment does not disclose any defect in material or workmanship, repairs will be made at a reasonable charge, which charges may include the costs of parts, labor, and transportation.

**THIS WARRANTY IS EXCLUSIVE, AND IS IN LIEU OF ANY OTHER WARRANTIES, EXPRESS OR IMPLIED, INCLUDING BUT NOT LIMITED TO WARRANTY OF MERCHANTABILITY OR WARRANTY OF FITNESS FOR A PARTICULAR PURPOSE.**

Graco's sole obligation and buyer's sole remedy for any breach of warranty shall be as set forth above. The buyer agrees that no other remedy (including, but not limited to, incidental or consequential damages for lost profits, lost sales, injury to person or property, or any other incidental or consequential loss) shall be available. Any action for breach of warranty must be brought within two (2) years of the date of sale.

**GRACO MAKES NO WARRANTY, AND DISCLAIMS ALL IMPLIED WARRANTIES OF MERCHANTABILITY AND FITNESS FOR A PARTICULAR PURPOSE, IN CONNECTION WITH ACCESSORIES, EQUIPMENT, MATERIALS OR COMPONENTS SOLD BUT NOT MANUFACTURED BY GRACO.** These items sold, but not manufactured by Graco (such as electric motors, switches, hose, etc.), are subject to the warranty, if any, of their manufacturer. Graco will provide purchaser with reasonable assistance in making any claim for breach of these warranties.

In no event will Graco be liable for indirect, incidental, special or consequential damages resulting from Graco supplying equipment hereunder, or the furnishing, performance, or use of any products or other goods sold hereto, whether due to a breach of contract, breach of warranty, the negligence of Graco, or otherwise.

## **FOR GRACO CANADA CUSTOMERS**

The Parties acknowledge that they have required that the present document, as well as all documents, notices and legal proceedings entered into, given or instituted pursuant hereto or relating directly or indirectly hereto, be drawn up in English. Les parties reconnaissent avoir convenu que la rédaction du présente document sera en Anglais, ainsi que tous documents, avis et procédures judiciaires exécutés, donnés ou intentés, à la suite de ou en rapport, directement ou indirectement, avec les procédures concernées.

# Graco Information

For the latest information about Graco products, visit [www.graco.com](http://www.graco.com).

**TO PLACE AN ORDER**, contact your Graco distributor or call to identify the nearest distributor.

**Phone:** 612-623-6928 **or Toll Free:** 1-800-533-9655, **Fax:** 612-378-3590

*All written and visual data contained in this document reflects the latest product information available at the time of publication. Graco reserves the right to make changes at any time without notice.*

Original instructions. This manual contains English. MM 312497

**Graco Headquarters:** Minneapolis  
**International Offices:** Belgium, China, Japan, Korea

**GRACO INC. AND SUBSIDIARIES • P.O. BOX 1441 • MINNEAPOLIS MN 55440-1441 • USA**

**Copyright 2009, Graco Inc. All Graco manufacturing locations are registered to ISO 9001.**

[www.graco.com](http://www.graco.com)  
Revised 11/2011

## Free Manuals Download Website

<http://myh66.com>

<http://usermanuals.us>

<http://www.somanuals.com>

<http://www.4manuals.cc>

<http://www.manual-lib.com>

<http://www.404manual.com>

<http://www.luxmanual.com>

<http://aubethermostatmanual.com>

Golf course search by state

<http://golfingnear.com>

Email search by domain

<http://emailbydomain.com>

Auto manuals search

<http://auto.somanuals.com>

TV manuals search

<http://tv.somanuals.com>