

NOTE:
Please read all instructions
carefully before using this
product

Table of Contents

Safety Notice

Hardware Identifier

Assembly Instruction

Parts List

Warranty

Ordering Parts

Model
MP 2100

Retain This
Manual for
Reference

02-09-05

OWNER'S
MANUAL

IMPEX

MARCY PLATINUM

MP 2100

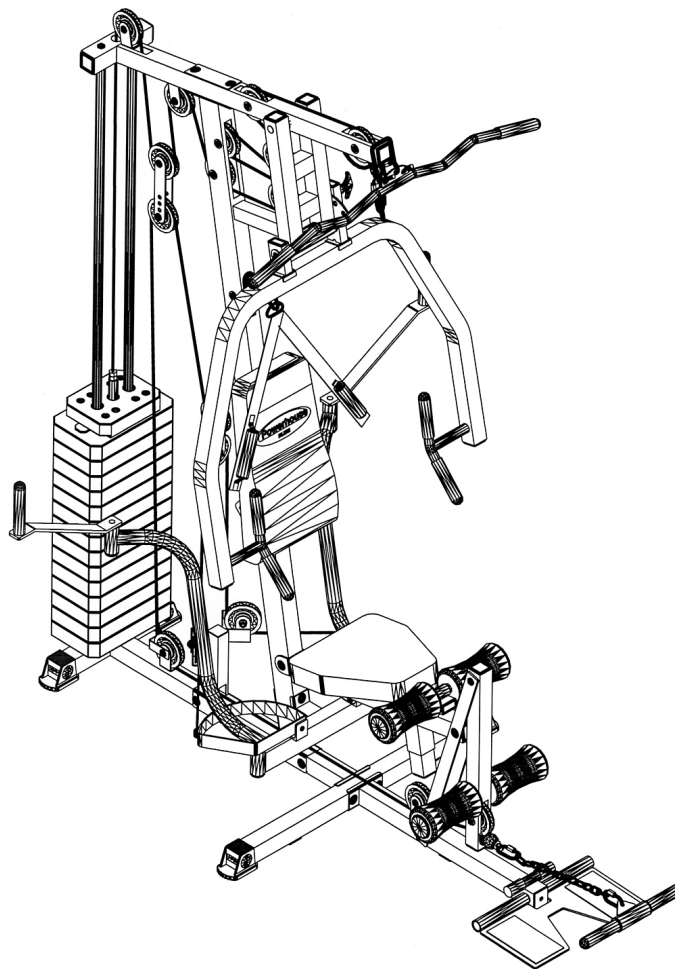

IMPEX INC.

14777 DON JULIAN RD., CITY OF INDUSTRY, CA 91746

Tel: (800) 999-8899 Fax: (626) 961-9966

www.impex-fitness.com

info@impex-fitness.com

TABLE OF CONTENTS

BEFORE YOU BEGIN.....	1
IMPORTANT SAFETY NOTICES.....	2
HARDWARE PACK.....	3
ASSEMBLY INSTRUCTIONS.....	6
WEIGHT RESISTANCE CHART.....	24
PARTS LIST.....	25
WARRANTY.....	26
ORDERING PARTS.....	26

BEFORE YOU BEGIN

Thank you for selecting the MARCY PLATINUM MP2100 by IMPEX INC. For your safety and benefit, read this manual carefully before using the machine. As a manufacturer, we are committed to provide you complete customer satisfaction. If you have any questions, or find there are missing or damaged parts, we guarantee you complete satisfaction through direct assistance from our factory. To avoid unnecessary delays, *please call our TOLL-FREE customer service number.* Our Customer Service Agents will provide immediate assistance to you.

Toll-Free Customer Service Number

1-800-999-8899

Mon. - Fri. 9 a.m. - 5 p.m. PST

www.impex-fitness.com

info@impex-fitness.com

IMPORTANT SAFETY NOTICE

PRECAUTIONS

This exercise machine is built for optimum safety. However, certain precautions apply whenever you operate a piece of exercise equipment. Be sure to read the entire manual before you assemble or operate your machine. In particular, note the following safety precautions:

1. **Keep children and pets away from the machine at all times. DO NOT leave children unattended in the same room with the machine.**
2. Only one person at a time should use the machine.
3. If the user experiences dizziness, nausea, chest pain, or any other abnormal symptoms, STOP the workout at once. CONSULT A PHYSICIAN IMMEDIATELY.
4. Position the machine on a clear, leveled surface. DO NOT use the machine near water or outdoors.
5. Keep hands away from all moving parts.
6. Always wear appropriate workout clothing when exercising. DO NOT wear robes or other clothing that could become caught in the machine. Running or aerobic shoes are also required when using the machine.
7. Use the machine only for its intended use as described in this manual. DO NOT use attachments not recommended by the manufacturer.
8. Do not place any sharp object around the machine.
9. Disabled person should not use the machine without a qualified person or physician in attendance.
10. Before using the machine to exercise, always do stretching exercises to properly warm up.
11. Never operate the machine if the machine is not functioning properly.

WARNING: BEFORE BEGINNING ANY EXERCISE PROGRAM, CONSULT YOUR PHYSICIAN. THIS IS ESPECIALLY IMPORTANT FOR INDIVIDUALS OVER THE AGE OF 35 OR PERSONS WITH PRE-EXISTING HEALTH PROBLEMS. READ ALL INSTRUCTIONS BEFORE USING ANY FITNESS EQUIPMENT. IMPEX INC. ASSUMES NO RESPONSIBILITY FOR PERSONAL INJURY OR PROPERTY DAMAGE SUSTAINED BY OR THROUGH THE USE OF THIS PRODUCT.

SAVE THESE INSTRUCTIONS.

HARDWARE PACK

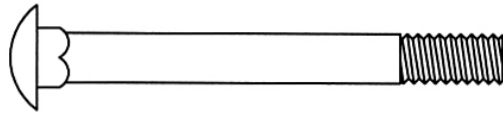

#71 M10 x 3 1/2" Carriage Bolt (Qty 2)

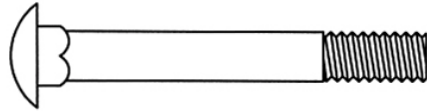

#77 M10 x 3" Carriage Bolt (Qty 2)

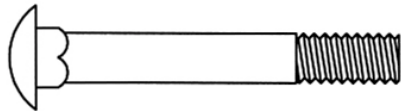

#72 M10 x 2 3/4" Carriage Bolt (Qty 9)

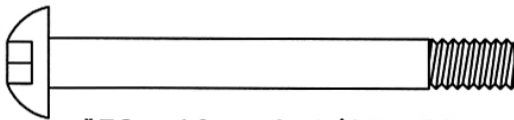

#73 M10 x 3 1/2" Allen Bolt (Qty 1)

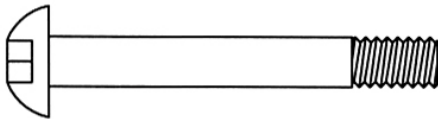

#74 M10 x 3" Allen Bolt (Qty 1)

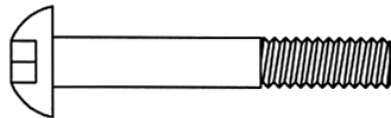

#78 M10 x 2 1/2" Allen Bolt (Qty 5)

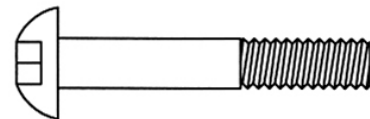

#79 M10 x 2 3/8" Allen Bolt (Qty 1)

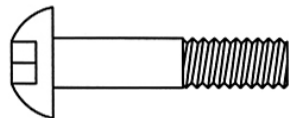

#80 M10 x 1 3/4" Allen Bolt (Qty 12)

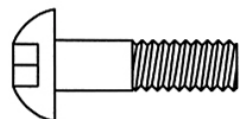

#81 M10 x 1 3/8" Allen Bolt (Qty 1)

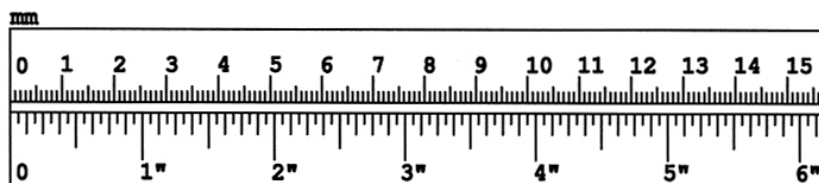

HARDWARE PACK

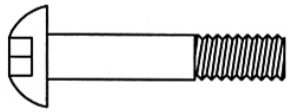

#82 M8 x 1 5/8" Allen Bolt (Qty 4)

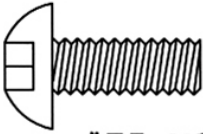

#75 M10 x 1" Allen Bolt (Qty 4)

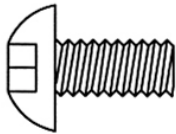

#76 M10 x 3/4" Allen Bolt (Qty 6)

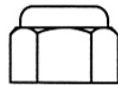

#89 M10 Aircraft Nut
(Qty 33)

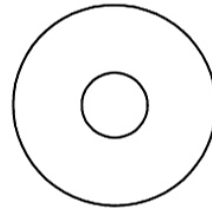

#66 Ø 1 3/8" Washer
(Qty 6)



#86 Ø 5/8" Washer
(Qty 5)



#87 Ø 3/4" Washer
(Qty 45)

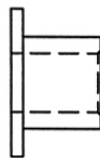

#60 Ø 5/8" x 5/8"
Pulley Bushing (Qty 10)



#61 Ø 5/8" x 1/2"
Pulley Bushing (Qty 2)

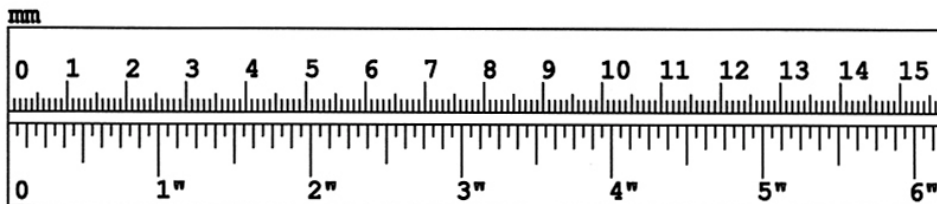

HARDWARE PACK

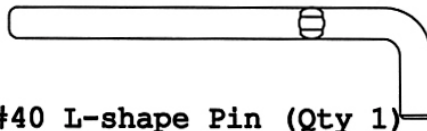

#40 L-shape Pin (Qty 1)



#37 Long Chain (Qty 1)



#38 Short Chain (Qty 1)

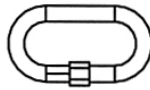

#39 C-Clip (Qty 5)

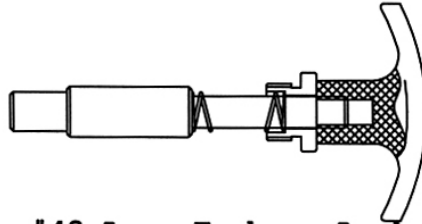

#43 Long T-shape Lock Pin (Qty 1)

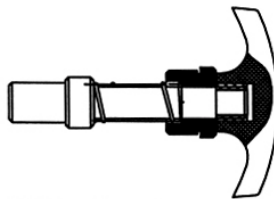

#52 Short T-shape Lock Pin (Qty 1)



#31 Front Press Base Axle (Qty 1)



#32 Front Press Axle (Qty 1)

ASSEMBLY INSTRUCTION

Tools Required Assembling the Machine: Two Adjustable Wrenches and Allen Wrenches

NOTE: It is strongly recommended this machine be assembled by two or more people to avoid possible injury.

STEP 1 (See Diagram 1)

- A.) Place the Middle Base Frame (#1) between the Front & Rear Base Frames (#2 & #3). Align the holes. Secure them with two M10 x 2 3/4" Carriage Bolts (#72), two Ø 3/4" Washers (#87), and two M10 Aircraft Nuts (#89).
- B.) Attach the Foot Plate (#15) to the Front Base Frame (#3). Align the holes. Insert the 15 3/4" Foot Plate Axle (#33) through the holes. Secure the Axle with a M8 x 3/4" Screw (#88).
- C.) Attach the Vertical Frame (#5) to the Rear Base Frame (#2). Secure it with two M10 x 2 3/4" Carriage Bolts (#72), Ø 3/4" Washers (#87), and M10 Aircraft Nuts (#89). DO NOT tighten the Nuts and Bolts yet.

DIAGRAM 1

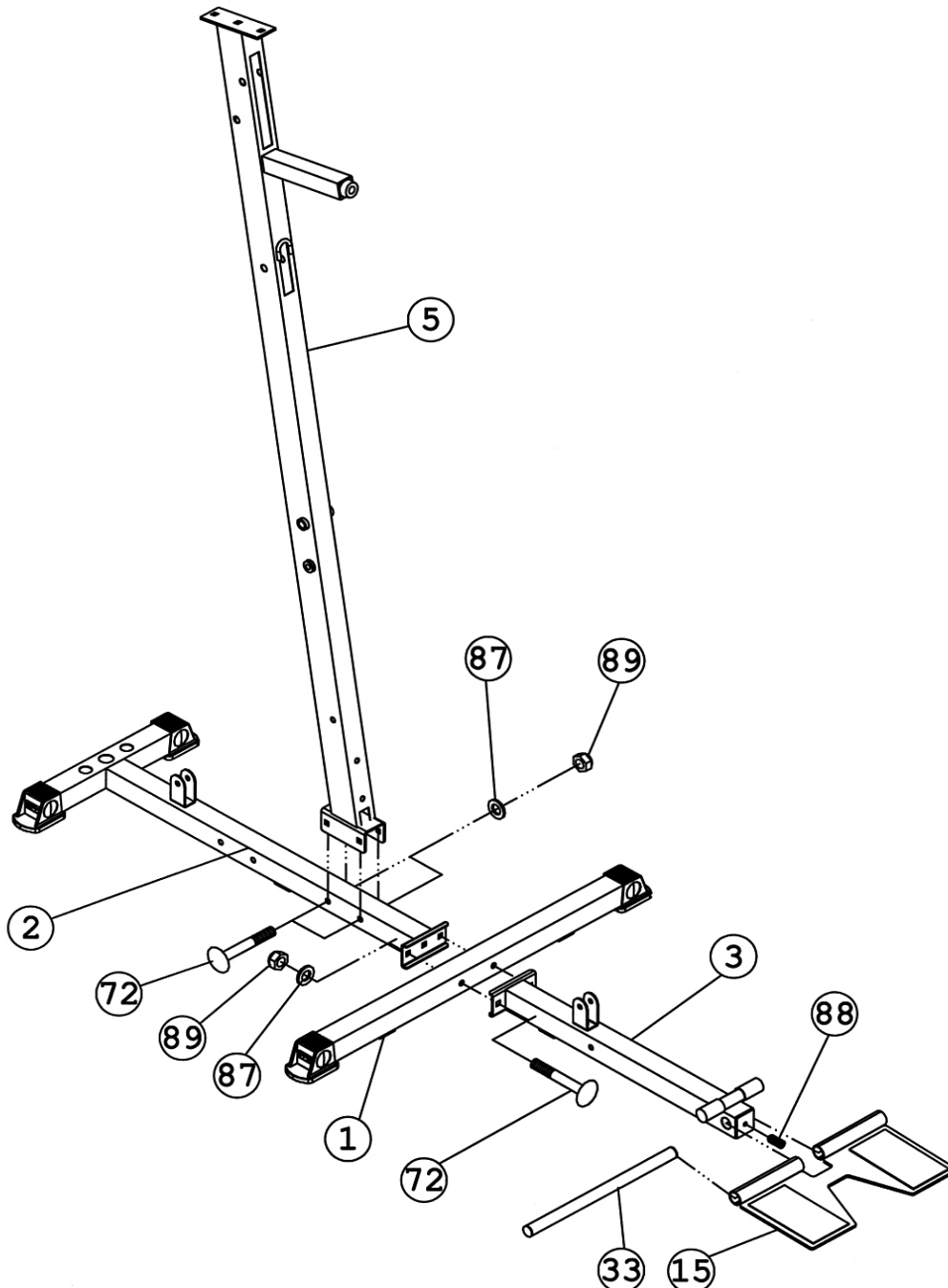

STEP 2 (See Diagram 2)

- A.) Place two \varnothing 2 1/2" Rubber Bumpers (#65) on the Rear Base Frame (#2). Align the holes and insert Two Guide Rods (#18) through the holes into the Rear Base Frame. Secure each Guide Rod with one M10 x 1" Allen Bolt (#75) and \varnothing 3/4" Washer (#87) from the bottom of Rear Base Frame.
- B.) Slide 14 Weight Plates (#48) onto the Guide Rods. Make sure all Plates are facing the same direction. Insert the Selector Rod (#41) through the center hole on the Weight Plates. Slide the Weight Selector Stem (#47) onto the Guide Rods.
- C.) Use the L-shape Pin (#40) to select desired number of Weight Plates to Exercise. NOTE: Each Plate weights 10 lbs. Please refer to the Weight Resistance Chart on page 24.

DIAGRAM 2

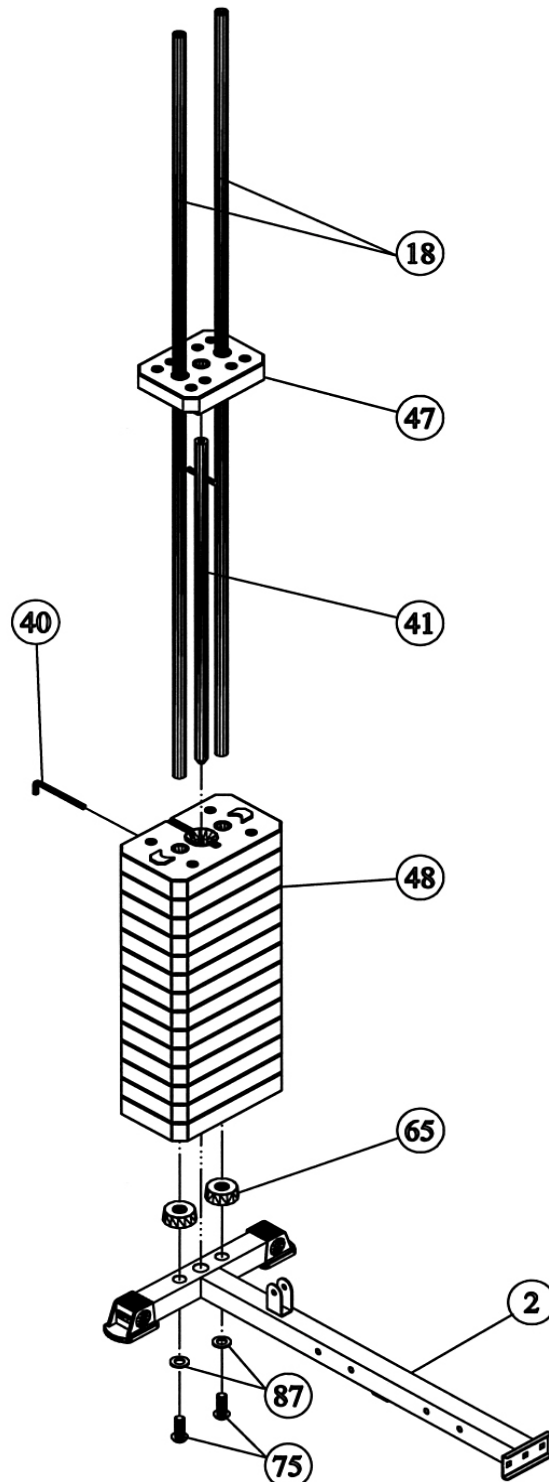

STEP 3 (See Diagram 3)

- A.) Attach the Upper Frame (#4) onto the two Guide Rods (#18). Secure each Guide Rod to the Upper Frame with one M10 x 1" Allen Bolt (#75) and $\varnothing \frac{3}{4}$ " Washer (#87). DO NOT tighten the Nuts and Bolts yet.
- B.) Place the Upper Frame (#4) onto the top of the Vertical Frame (#5). Secure it with one 5 1/2" x 2" Bracket (#27), two M10 x 2 3/4" Carriage Bolts (#72), two $\varnothing \frac{3}{4}$ " Washers (#87), and two M10 Aircraft Nuts (#89).
- C.) Securely tighten all Nuts and Bolts previously installed.
- D.) Attach the Backrest Board (#22) to the Backrest Support Frame (#12). Secure it with two M8 x 1 5/8" Allen Bolts (#82) and $\varnothing 5/8$ " Washers (#86).
- E.) Attach the Backrest Support Frame (#12) to the Vertical Frame (#5). Secure it with one M10 x 3 1/2" Allen Bolt (#73), two $\varnothing \frac{3}{4}$ " Washers (#87), and one M10 Aircraft Nut (#89).
- F.) Thread the Long T-shape Lock Pin (#43) into the hole on the Vertical Frame. Insert the Pin into selected hole on the Backrest Support Frame to obtain the desired Backrest position.
- G.) Attach the Seat Support Frame (#6) to the Vertical Frame (#5). Secure it with one M10 x 2 3/4" Carriage Bolt (#72), $\varnothing \frac{3}{4}$ " Washer (#87), and M10 Aircraft Nut (#89).

STEP 4 (See Diagram 4)

- A.) Attach two Diagonal Support Frames (#7) to the Front Base Frame (#3). Secure it with one M10 x 3" Carriage Bolt (#77), $\text{\O} \frac{3}{4}$ " Washer (#87), and M10 Aircraft Nut (#89).
- B.) Secure the two Diagonal Supports to the Seat Support Frame (#6) with one M10 x 3" Carriage Bolt (#77), $\text{\O} \frac{3}{4}$ " Washer (#87), and M10 Aircraft Nut (#89).
- C.) Attach the Leg Developer (#8) to the top of the Diagonal Support Frames (#7). Secure it with one M10 x 3" Allen Bolt (#74), two $\text{\O} \frac{3}{4}$ " Washers (#87), and one M10 Aircraft Nut (#89). Do not over tighten the Bolt. Make sure the Leg Developer is able to swivel.
- D.) Attach the Front Press Base (#10) to the Upper Frame (#4). Align the holes and insert the Front Press Base Axle (#31). Secure it with two M10 x $\frac{1}{2}$ " Allen Bolts (#85).

DIAGRAM 4

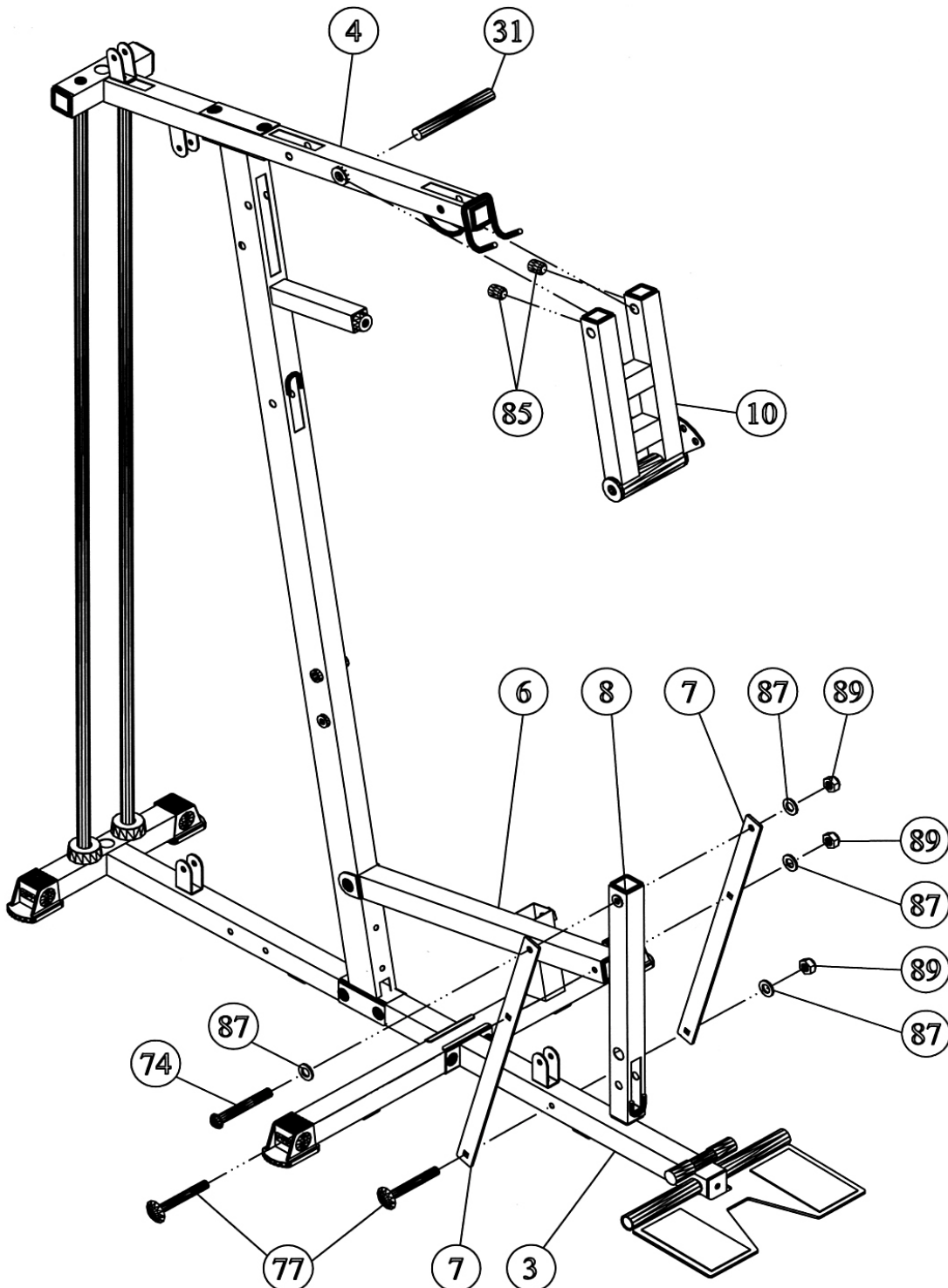

STEP 5 (See Diagram 5)

- A.) Attach the Front Press (#11) to the pivot on the Front Press Base (#10). Align the holes and insert the Front Press Axle (#32) through the holes.
- B.) Secure each end of the Axle with one M10 x 3/4" Allen Bolt (#76) and \varnothing 1 3/8" Washer (#66). Secure the Axle to the Front Press with two M8 x 3/4" Screws (#88).
- C.) Thread a Short T-shape Lock Pin (#52) into the hole on the Front Press. Use the Lock Pin to secure the desired Front Press exercise position.
- D.) Attach the Butterfly Pulley Bracket (#17) to the Rear Base Frame (#2). Secure it with two M10 x 2 3/4" Carriage Bolts (#72), \varnothing 3/4" Washers (#87), and M10 Aircraft Nuts (#89).

DIAGRAM 5

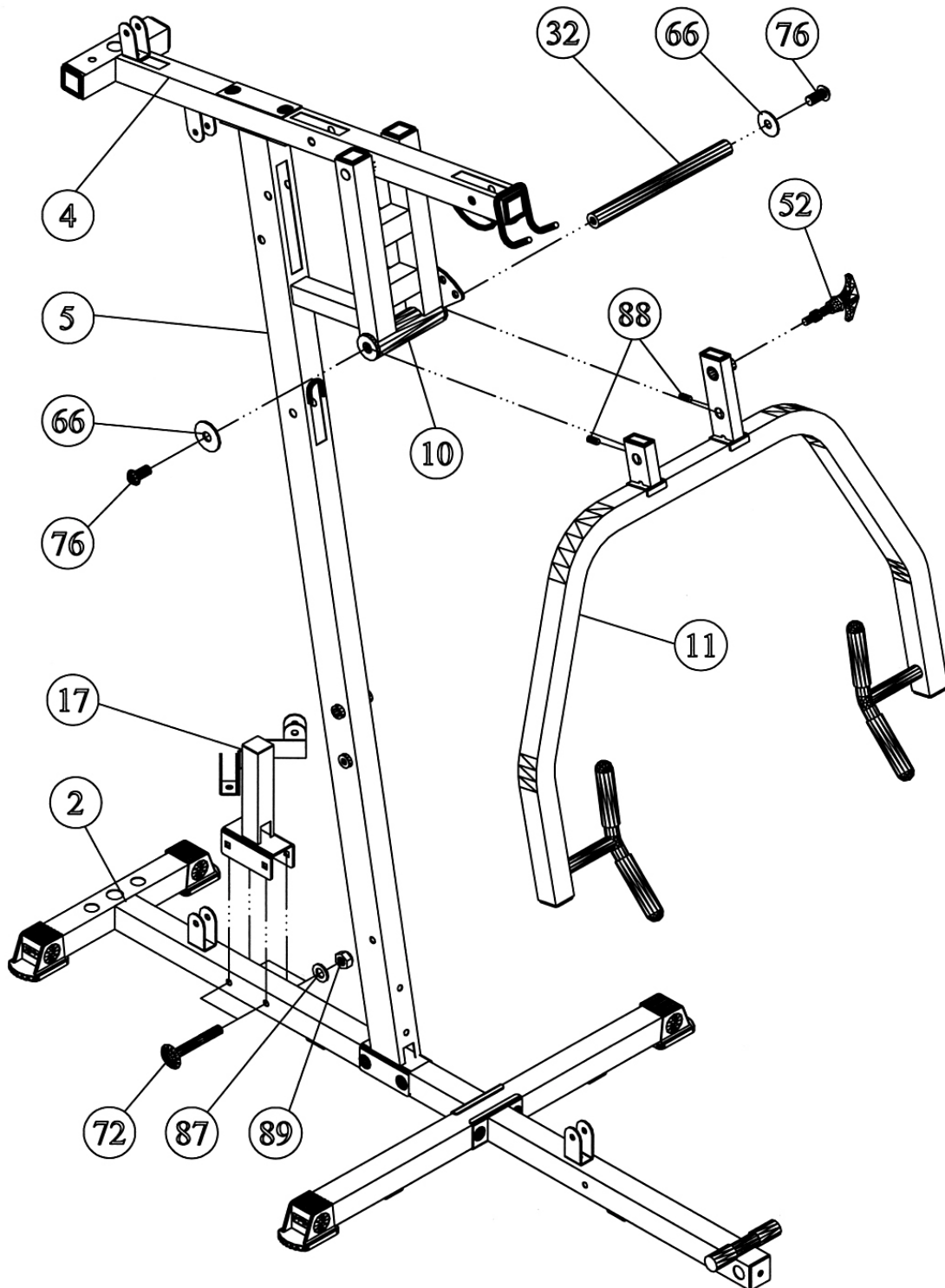

STEP 6 (See Diagram 6)

- A.) Attach the Butterfly Base (#14) to the Vertical Frame (#5). Secure it with one 4 3/4" x 2" Bracket (#26), two M10 x 3 1/2" Carriage Bolts (#71), two Ø 3/4" Washers (#87), and two M10 Aircraft Nuts (#89).
- B.) Insert the Right Butterfly (#20) into the right pivot on Butterfly Base. Secure it with one M10 x 3/4" Allen Bolt (#76) and Ø1 3/8" Washer (#66) from the bottom.
- C.) Insert the Butterfly Handle (#13) into the pivot on the Right Butterfly. Secure it with one M10 x 3/4" Allen Bolt (#76) and Ø 1 3/8" Washer (#66).
- D.) Repeat Procedures B and C above to install the other side.

DIAGRAM 6

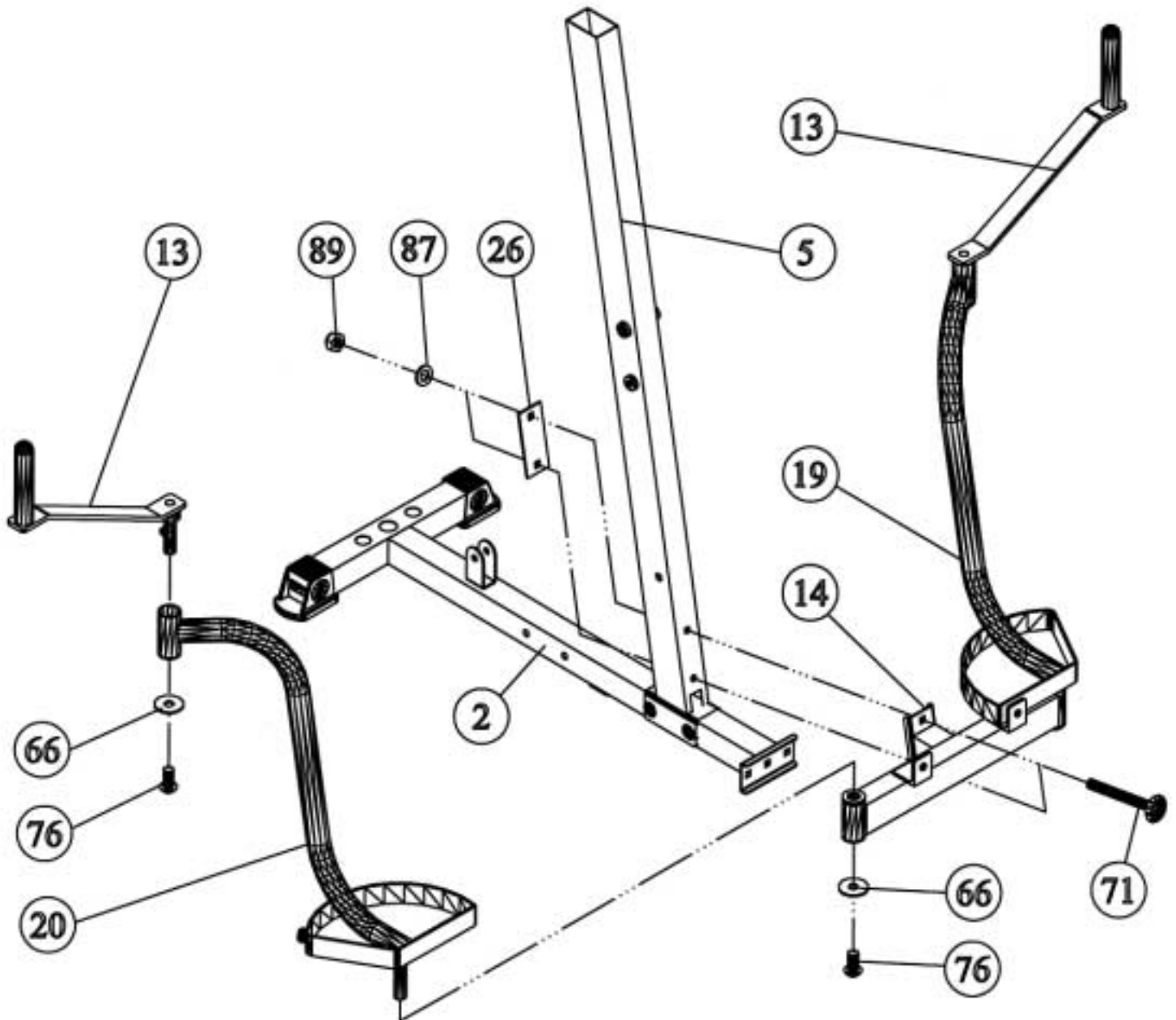

STEP 7 (See Diagram 7)

- A.) Place the Seat Pad (#21) onto the Seat Post (#9). Secure it with two M8 x 1 5/8" Allen Bolts (#82) and \varnothing 5/8" Washers (#86).
- B.) Insert the Seat Post into the opening on the Seat Support Frame (#6). Use a Lock Knob (#44) to obtain the desired height of Seat.
- C.) Insert two Foam Tubes (#28) halfway through the holes on Seat Post and Leg Developer. Push four Foam Rolls (#64) onto the Tubes from both ends. Plug four Foam Roll End Caps (#58) onto the Tubes.

DIAGRAM 7

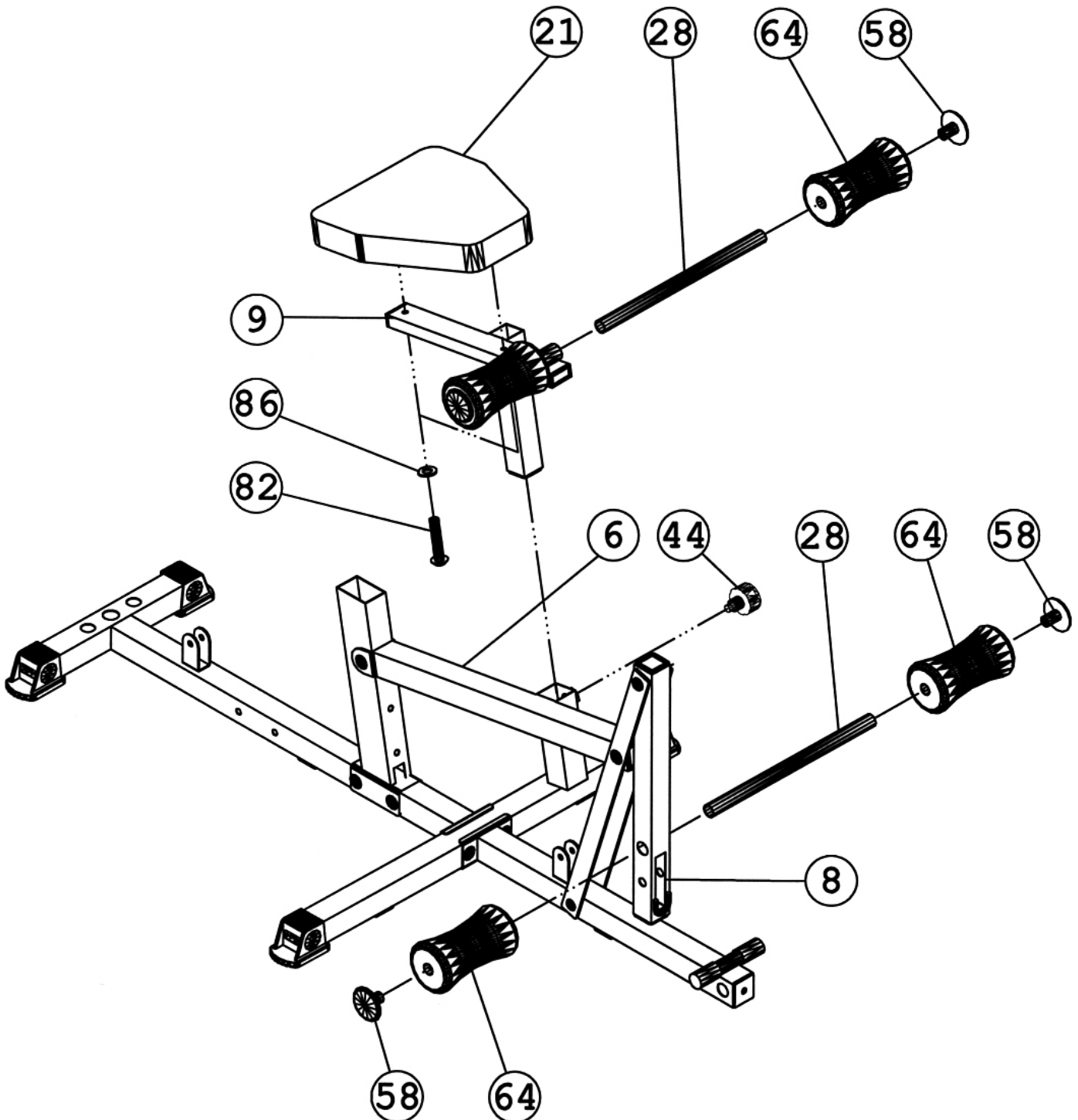

CABLE LOOP DIAGRAM

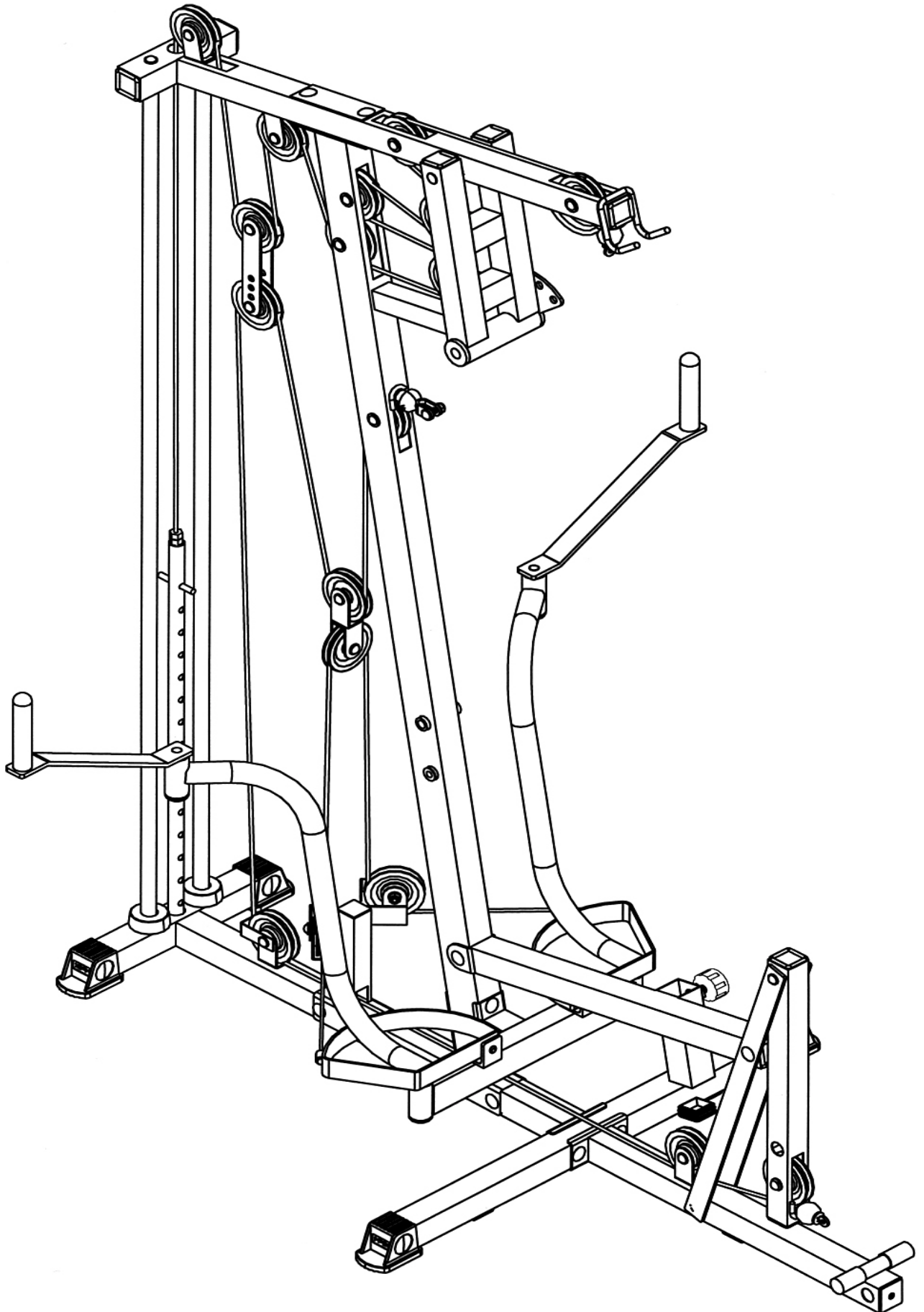

STEP 8 (See Diagram 8 & Upper Cable Loop Diagram)

- A.) Attach the 154" Upper Cable (#34) to the opening on the front Upper Frame (#4). Make sure the ball stopper is underneath the Frame. Attach a Pulley (#45) to the Cable. Secure the Pulley with one M10 x 2 1/2" Allen Bolt (#78), two Ø 5/8" x 5/8" Pulley Bushings (#60), and one M10 Aircraft Nut (#89).
- B.) Draw the Cable over the Pulley along the Upper Frame towards the back of the machine to the opening in the middle of Upper Frame. Repeat Procedure B above to install a Pulley.
- C.) Draw the Cable around the Pulley then back to the upper open bracket on the back of Front Press Base (#10). Attach a Pulley to the bracket. Secure it with one M10 x 1 3/4" Allen Bolt (#80), two Ø 3/4" Washers (#87), and one M10 Aircraft Nut (#89).
- D.) Draw the Cable around the Pulley then towards the upper opening on the Vertical Frame (#5). Repeat Procedure B above to install a Pulley.
- E.) Draw the Cable around the Pulley and back to the lower open bracket on the back of Front Press Base (#10). Repeat Procedure C above to install a Pulley.
- F.) Draw the Cable around the Pulley then to the lower opening on the Upper Frame. Repeat Procedure B above to install a Pulley.
- G.) Draw the Cable underneath the Pulley then pull upward to the open bracket underneath the Upper Frame. Repeat Procedure C above to install a Pulley.
- H.) Draw the Cable around the Pulley then downward. Attach a Pulley to the two Double Floating Pulley Brackets (#24). Repeat Procedure C above to install a Pulley. Let the Bracket hanging for now.
- I.) Draw the Cable around the Pulley then upward to the opening on the back of Upper Frame. Repeat the Procedure C above to install a Pulley.
- J.) Draw the Cable around the Pulley then downward to the Selector Rod (#41). Thread the Head Bolt at end of the Cable into the Selector Rod.

DIAGRAM 8

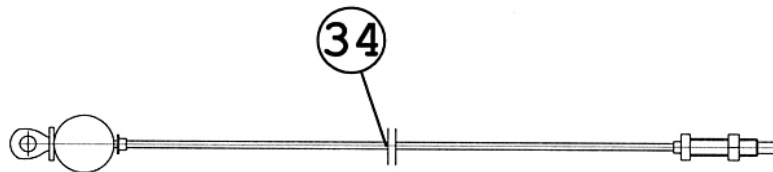
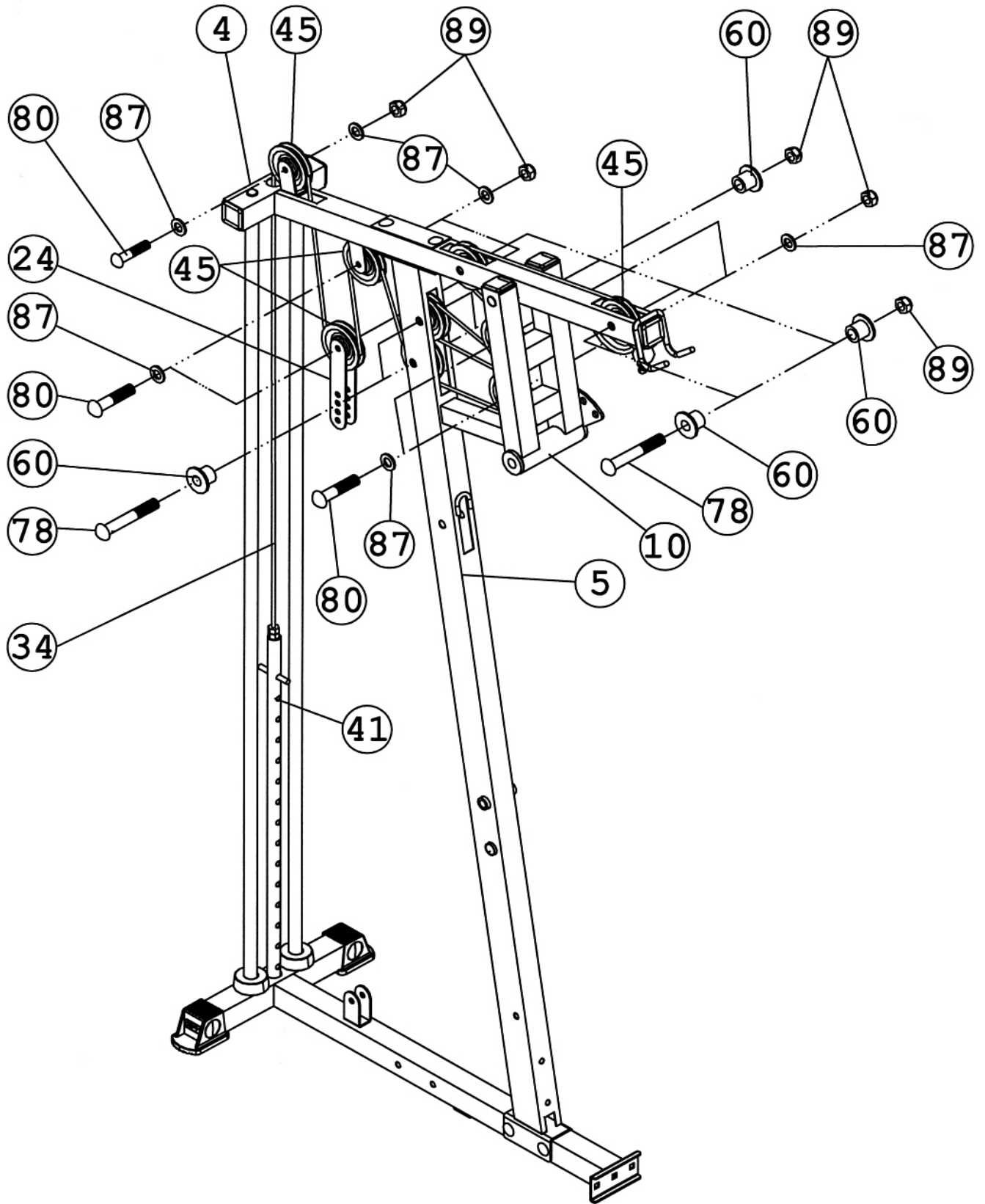

Upper Cable Loop Diagram

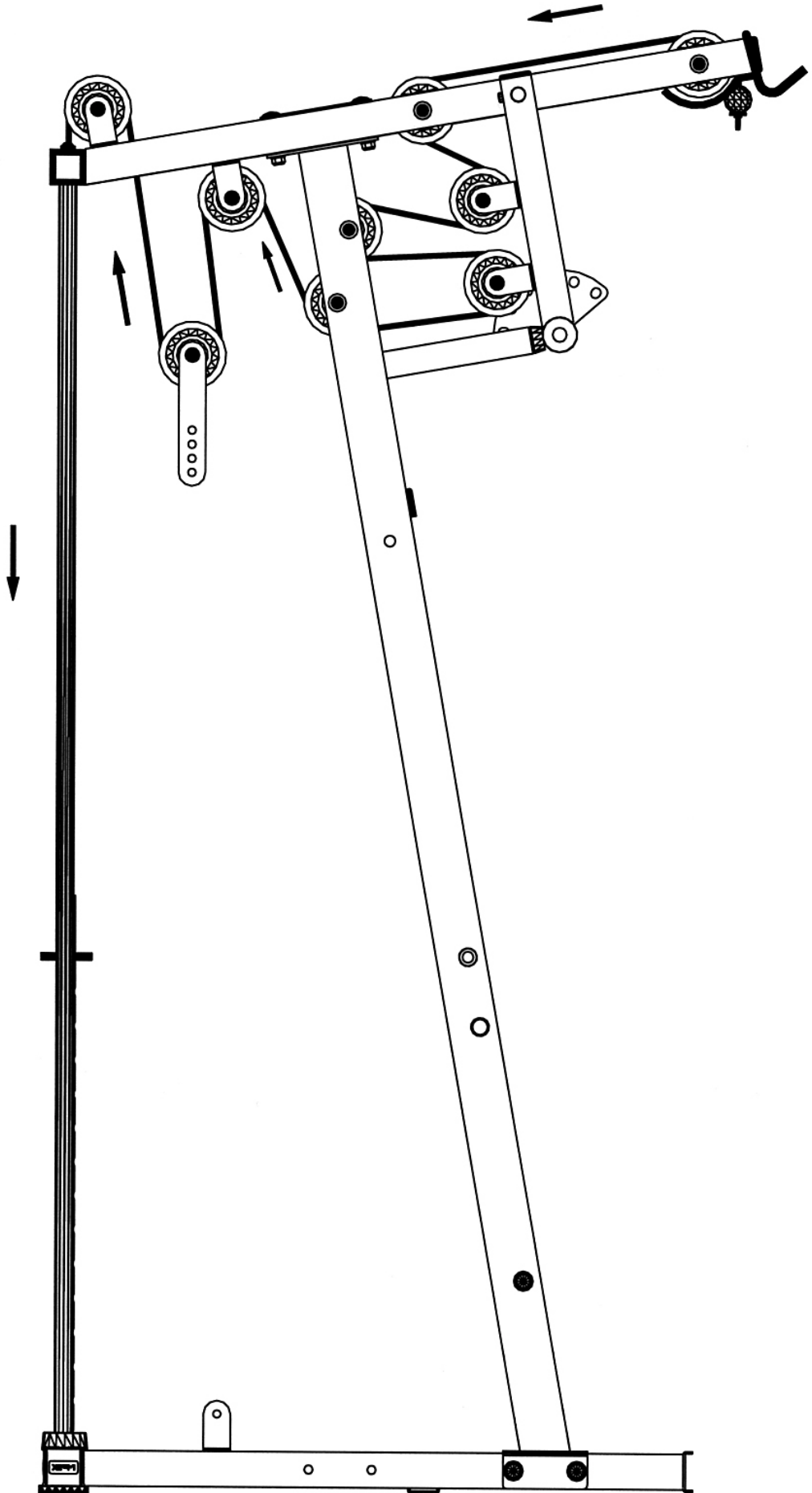

STEP 9 (See Diagram 9 & Lower Cable Loop Diagram)

- A.) Attach the 156" Lower Cable (#36) to the opening on the Leg Developer (#8). Attach a Pulley to the opening. Secure it with one M10 x 2 3/8" Allen Bolt (#79), two \varnothing 5/8" x 1/2" Pulley Bushings (#61), and one M10 Aircraft Nut (#89).
- B.) Draw the Cable underneath the Pulley to the open bracket on the Front Base Frame (#3). Attach a Pulley to the bracket. Secure it with one M10 x 1 3/4" Allen Bolt (#80), two \varnothing 3/4" Washers (#87), and one M10 Aircraft Nut (#89).
- C.) Draw the Cable underneath the Pulley towards back of the machine through the bottom openings on the Vertical Frame (#5) and Butterfly Pulley Bracket (#17) to the open bracket on the Rear Base Frame (#2). Repeat Procedure B above to install a Pulley with a L-shape Cable Bracket (#91).
- D.) Draw the Cable underneath the Pulley then pull upward to the Double Floating Pulley Bracket (#24) previously installed in STEP-8. Repeat the Procedure B above to install a Pulley. After completing the entire cable system, come back to the Double Floating Pulley Bracket and adjust the height of the lower Pulley to adjust the tightness of the Cables.
- E.) Draw the Cable around the Pulley then downward. Attach the Cable to an Angled Double Floating Pulley Bracket (#23). Repeat Procedure B above to install a Pulley. Let the Bracket hanging for now.
- F.) Draw the Cable around the Pulley then upward to the opening on the Vertical Frame (#5). Attach a Pulley to the opening. Secure it with one M10 x 2 1/2" Allen Bolt (#78), two \varnothing 5/8" x 5/8" Pulley Bushings (#60), and one M10 Aircraft Nut (#89).
- G.) Insert the Cable through a Nylon Ball Stopper (#96). Attach the Cable to a U-shape Cable Connector (#90). Secure it with one M10 x 1 3/8" Allen Bolt (#81), two \varnothing 3/4" Washers (#87), and one M10 Aircraft Nut (#89).

DIAGRAM 9

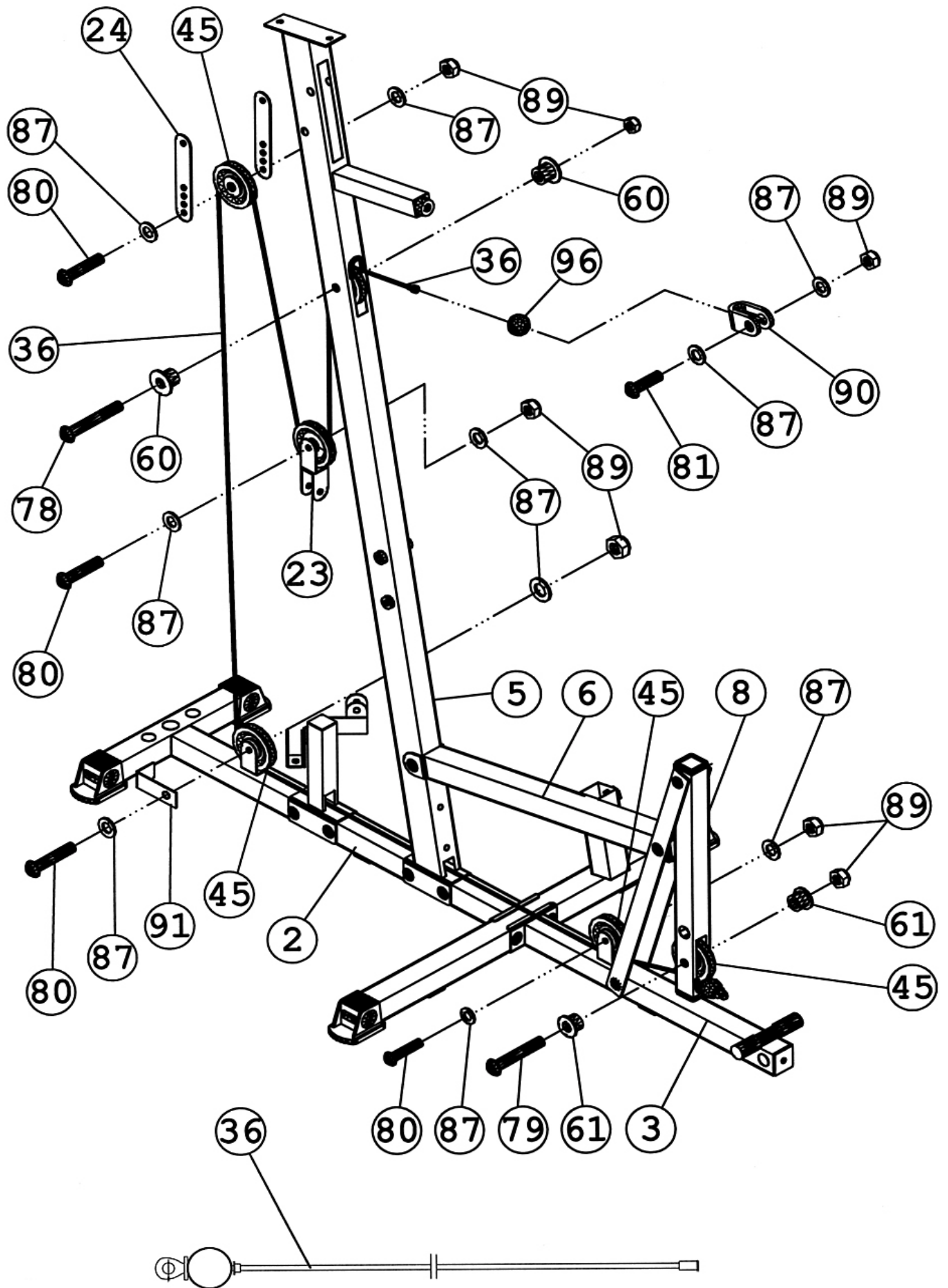

Lower Cable Loop Diagram

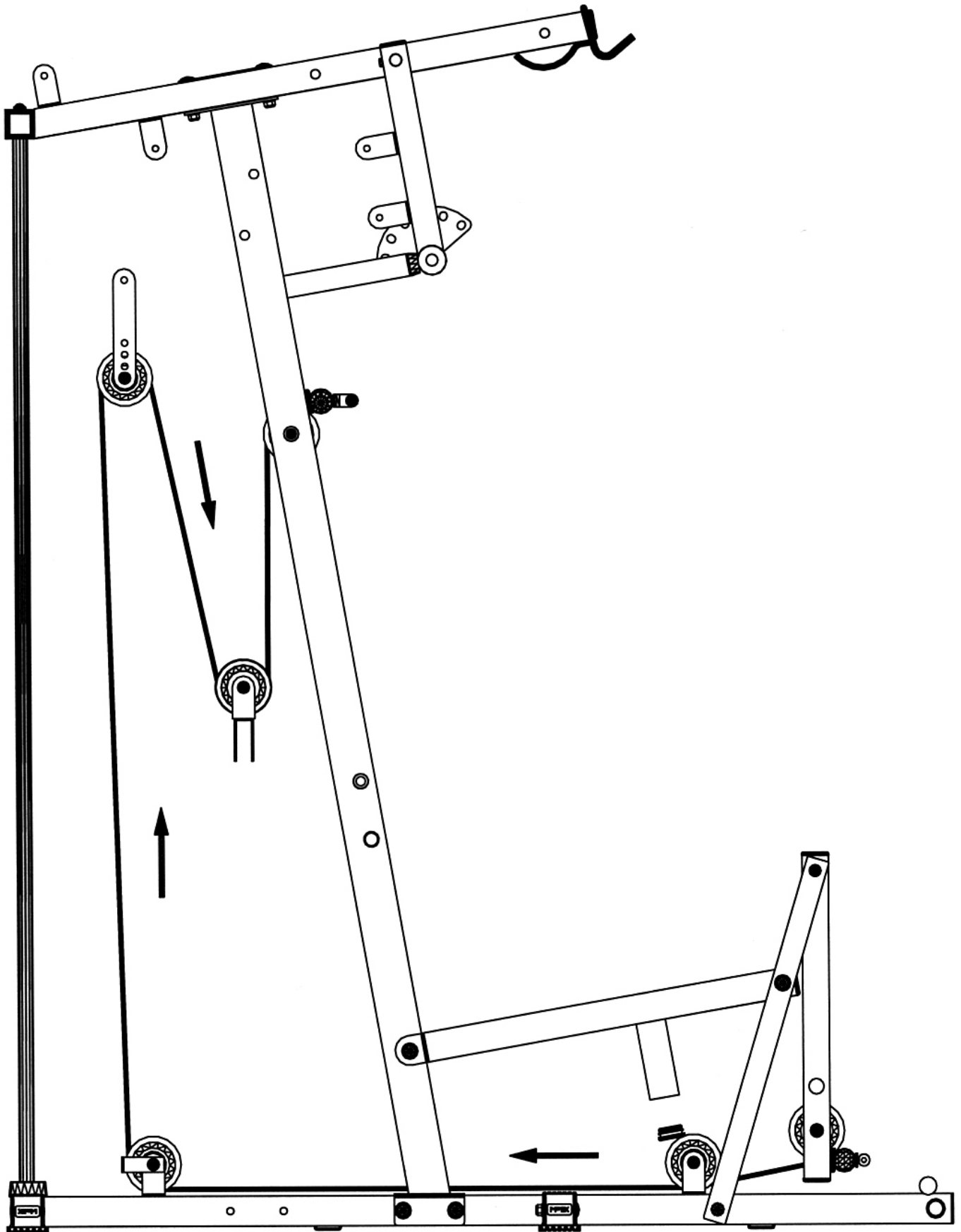

STEP 10 (See Diagram 10 & Butterfly Cable Loop Diagram)

- A.) Attach one end of the 87" Butterfly Cable (#35) to the open slot on Right Butterfly (#20).
- B.) Draw the Cable to the open slot on the Butterfly Pulley Bracket (#17). Attach a Pulley to the open slot. Secure the Pulley with one M10 x 1 3/4" Allen Bolt (#80), one L-shape Cable Bracket (#91), two Ø 3/4" Washers (#87), and one M10 Aircraft Nut (#89).
- C.) Draw the Cable underneath the Pulley then upward to the Angled Double Floating Pulley Bracket (#23) previously installed in STEP-9. Install a Pulley.
- D.) Draw the Cable around the Pulley then downward to the left open slot on the Butterfly Pulley Bracket. Repeat the Procedure B above to install a Pulley.
- E.) Pull the Cable and attach it to the open slot on the Left Butterfly (#19).

DIAGRAM 10

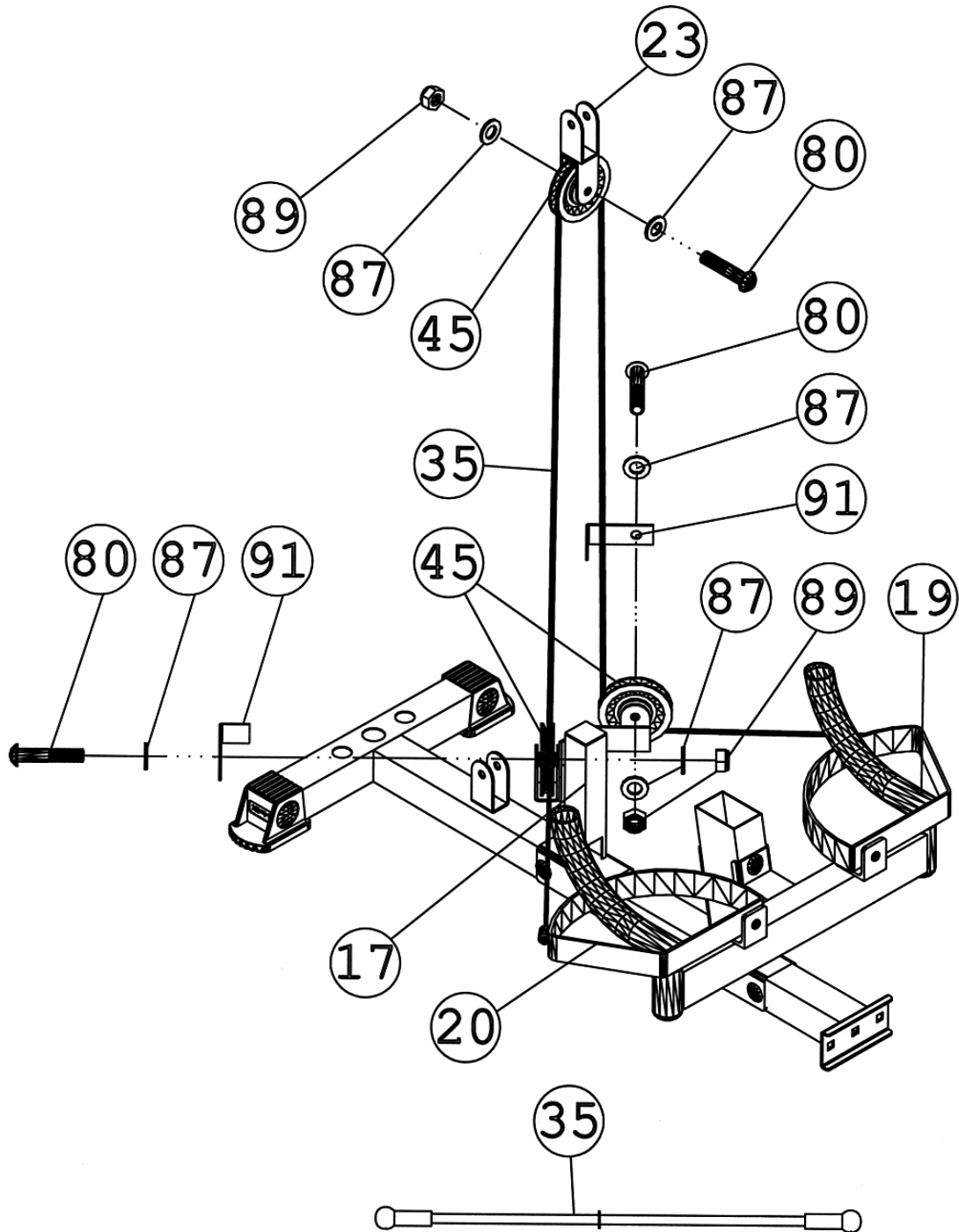

Butterfly Cable Loop Diagram

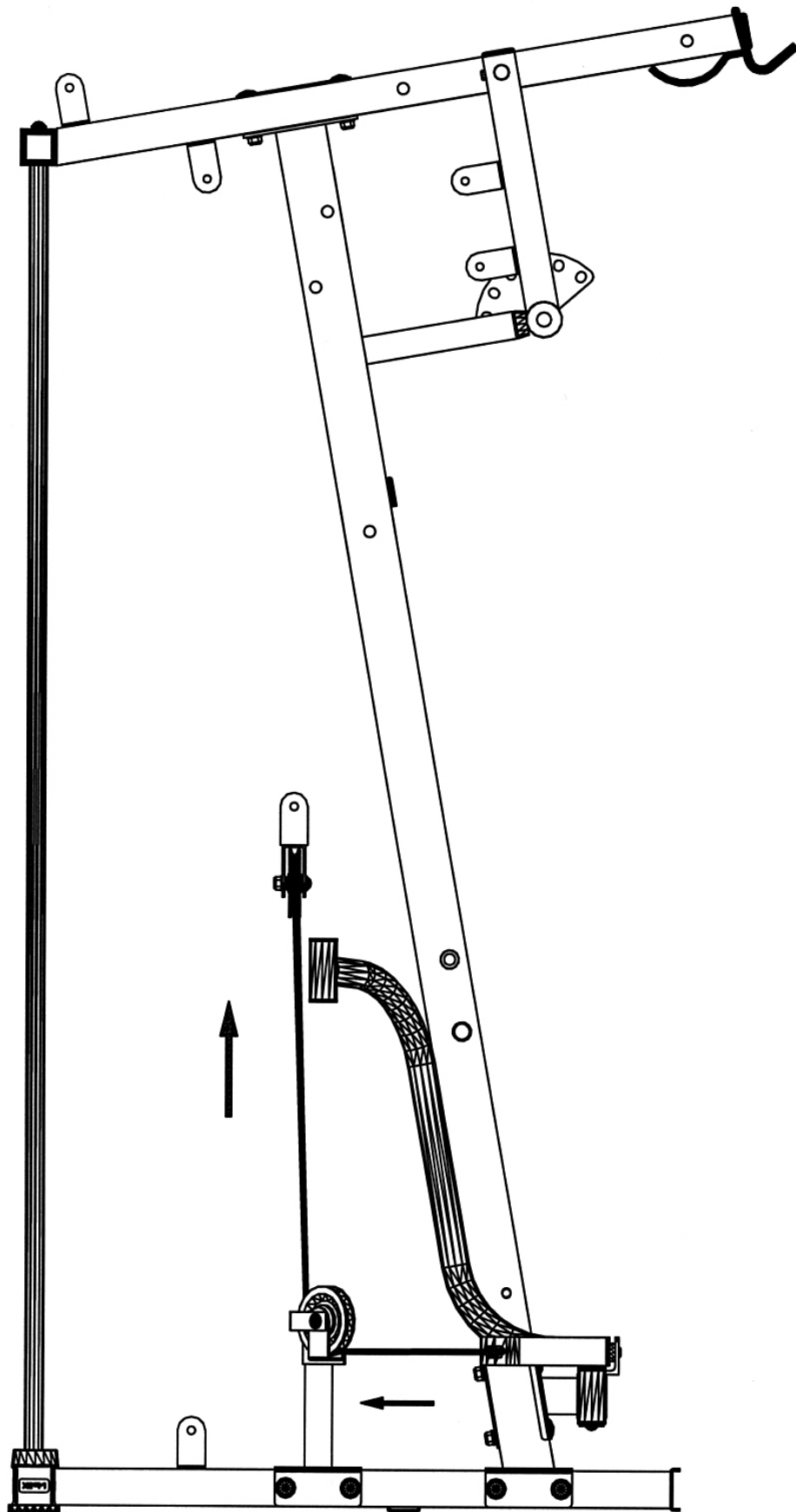

STEP 11 (See Diagram11)

- A.) Connect the Lat Bar (#25) to the Upper Cable with two C-clips (#39) and one short Chain (#38).
- B.) Connect the Abdominal Strap (#95) to the mid Cable with a C-clip (#39).
- C.) Connect the Shiver Bar (#29) to the Lower Cable with two C-clips (#39) and one Long Chain (#37).

DIAGRAM 11

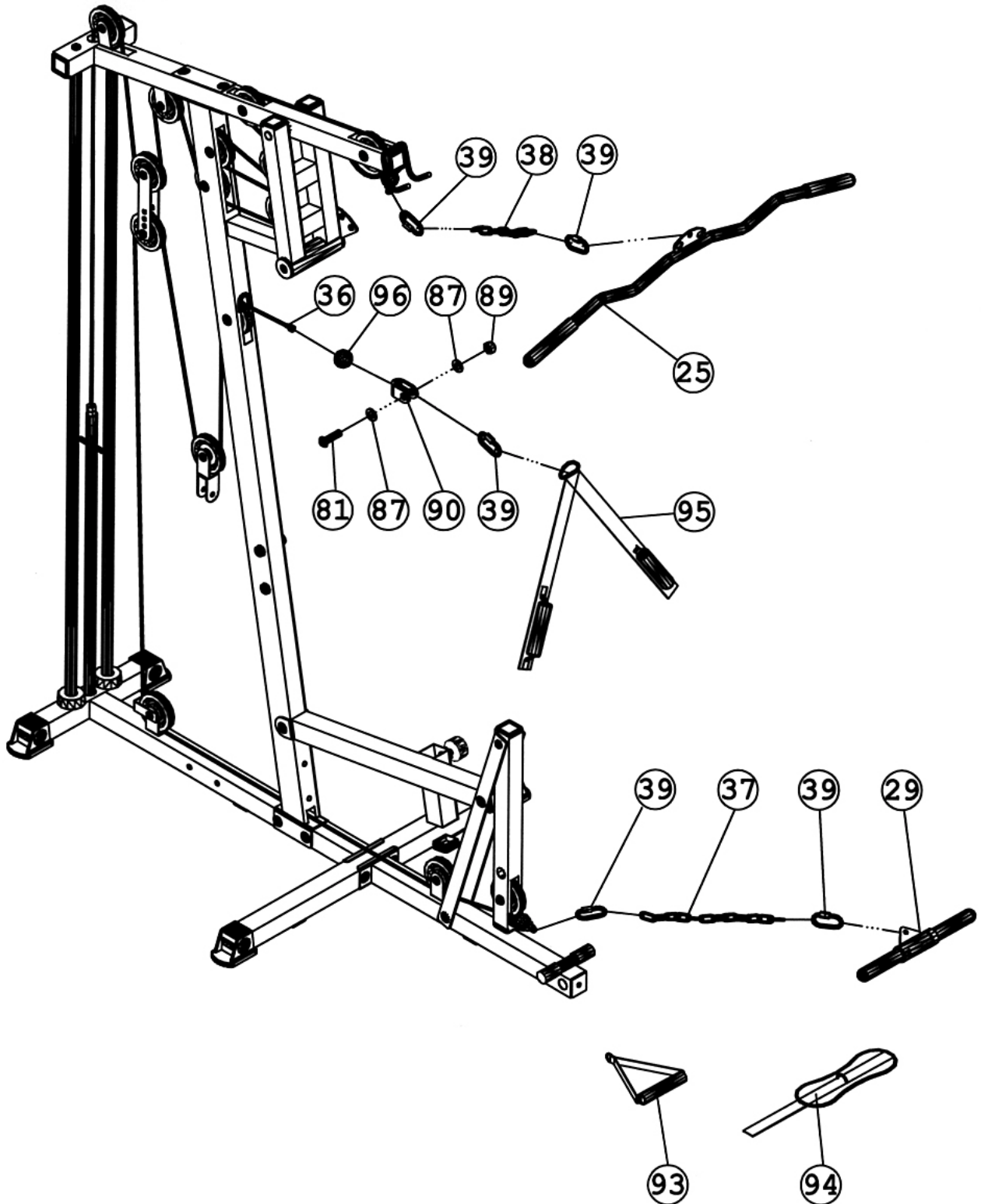

WEIGHT RESISTANCE CHART

	WEIGHT PLATE								
Station	1	2	3	4	5	6	7	8	9
Low Pulley	22	33	44	55	66	77	88	99	110
Lat Pull	30	40	50	60	70	80	90	100	110
Butterfly	10	16	22	28	34	40	46	52	58
Front Press	20	34	48	62	76	90	104	118	132
AB Crunch	22	33	44	55	66	77	88	99	110
Leg Developer	26	38	50	62	74	86	98	110	122

	WEIGHT PLATE								
Station	10	11	12	13	14				
Low Pulley	121	132	143	154	165				
Lat Pull	120	130	140	150	160				
Butterfly	64	70	76	82	88				
Front Press	146	160	174	188	202				
AB Crunch	121	132	143	154	165				
Leg Developer	134	146	158	170	182				

*Numbers are approximate. Actual weight may vary.

*Value for butterfly is for each arm.

PARTS LIST

KEY NO.	DESCRIPTION	Q'ty			
1	Middle Base Frame	1	51	6" Front Press Handle Grip	4
2	Rear Base Frame	1	52	Short T-shape Lock Pin	1
3	Front Base Frame	1	53	Ø 1 3/8" Bushing	2
4	Upper Frame	1	54	1" x 2" End Cap	2
5	Vertical Frame	1	55	2" Square End Cap	4
6	Seat Support Frame	1	56	1 3/4" Square End Cap	5
7	Diagonal Support Frame	2	57	1 1/2" Square End Cap	1
8	Leg Developer	1	58	Foam Roll End Cap	4
9	Seat Post	1	59	Ø 1" End Cap	2
10	Front Press Base	1	60	Ø 5/8" x 5/8" Pulley Bushing	10
11	Front Press	1	61	Ø 5/8" x 1/2" Pulley Bushing	2
12	Backrest Support Frame	1	62	Ø 1 1/2" Spacer	10
13	Butterfly Handle	2	63	Ø 1" Spacer	4
14	Butterfly Base	1	64	Foam Roll	4
15	Foot Plate	1	65	Ø 2 1/2" Rubber Bumper	2
16	Anti Slip Sticker	2	66	Ø 1 3/8" Washer	6
17	Butterfly Pulley Bracket	1	67	Ø 1" Sleeve	2
18	Guide Rod	2	68	Ø 1 7/8" Bushing	2
19	Left Butterfly Base	1	69	Ø 1" Rubber Bumper	2
20	Right Butterfly Base	1	70	Ø 1 1/2" Rubber Bumper	1
21	Seat Pad	1	71	M10 x 3 1/2" Carriage Bolt	2
22	Backrest Board	1	72	M10 x 2 3/4" Carriage Bolt	9
23	Angled Double Floating Pulley Bracket	1	73	M10 x 3 1/2" Allen Bolt	1
24	Double Floating Pulley Bracket	2	74	M10 x 3" Allen Bolt	1
25	Lat Bar	1	75	M10 x 1" Allen Bolt	4
26	4 3/4" x 2" Bracket	1	76	M10 x 3/4" Allen Bolt	6
27	5 1/2" x 2" Bracket	1	77	M10 x 3" Carriage Bolt	2
28	Foam Tube	2	78	M10 x 2 1/2" Allen Bolt	5
29	Shiver Bar Frame	1	79	M10 x 2 3/8" Allen Bolt	1
30	Shiver Bar Handle	1	80	M10 x 1 3/4" Allen Bolt	12
31	Front Press Base Axle	1	81	M10 x 1 3/8" Allen Bolt	1
32	Front Press Axle	1	82	M8 x 1 5/8" Allen Bolt	4
33	15 3/4" Foot Plate Axle	1	83	M10 x 3/4" Allen Screw	2
34	154" Upper Cable	1	84	M6 x 5/8" Philips Screw	1
35	87" Butterfly Cable	1	85	M10 x 1/2" Allen Bolt	2
36	156" Lower Cable	1	86	Ø 5/8" Washer	5
37	Long Chain	1	87	Ø 3/4" Washer	45
38	Short Chain	1	88	M8 x 3/4" Screw	3
39	C-clip	5	89	M10 Aircraft Nut	33
40	L-shape Pin	1	90	U-shape Cable Connector	1
41	Selector Rod	1	91	L-shape Cable Bracket	3
42	Selector Rod Head Plastic Cover	1	92	1" x 2" Slim End Cap	4
43	Long T-shape Lock Pin	1	93	Single Handle	1
44	Lock Knob	1	94	Ankle Strap	1
45	Pulley	18	95	Abdominal Strap	1
46	1 3/4" Square End Cap	2	96	Nylon Ball Stopper	1
47	Selector Stem	1			
48	Weight Plate	14			
49	2" Base Frame End Cap	4			
50	5" Handle Grip	6			

IMPEX INC.

LIMITED WARRANTY

IMPEX Inc. ("IMPEX") warrants this product to be free from defects in workmanship and material, under normal use and service conditions, for a period of two years on the Frame from the date of purchase. This warranty extends only to the original purchaser. IMPEX's obligation under this Warranty is limited to replacing or repairing, at IMPEX's option.

All returns must be pre-authorized by IMPEX. Pre-authorization may be obtained by calling IMPEX Customer Service Department at 1-800-999-8899. All freights on products returned to IMPEX must be prepaid by the customer. This warranty does not extend to any product or damage to a product caused by or attributable to freight damage, abuse, misuse, improper or abnormal usage or repairs not provided by an IMPEX authorized service center or for products used for commercial or rental purposes. No other warranty beyond that specifically set forth above is authorized by IMPEX.

IMPEX is not responsible or liable for indirect, special or consequential damages arising out of or in connection with the use or performance of the product or other damages with respect to any economic loss, loss of property, loss of revenues or profits, loss of enjoyments or use, costs of removal, installation or other consequential damages or whatsoever natures. Some states do not allow the exclusion or limitation of incidental or consequential damages. Accordingly, the above limitation may not apply to you.

The warranty extended hereunder is in lieu of any and all other warranties and any implied warranties of merchantability or fitness for a particular purpose is limited in its scope and duration to the terms set forth herein. Some states do not allow limitations on how long an implied warranty lasts. Accordingly, the above limitation may not apply to you.

This warranty gives you specific legal right. You may also have other rights which vary from state to state. Register on-line at www.impex-fitness.com

IMPEX INC.
14777 Don Julian
City of Industry, CA 91746

ORDERING REPLACEMENT PARTS

Replacement parts can be ordered by calling our Customer Service Department toll-free at **1-800-999-8899** during our regular business hours: Monday through Friday, 9 am until 5 pm Pacific standard time.

info@impex-fitness.com

When ordering replacement parts, always give the following information.

1. Model
2. Description of Parts
3. Part Number
4. Date of Purchase

Free Manuals Download Website

<http://myh66.com>

<http://usermanuals.us>

<http://www.somanuals.com>

<http://www.4manuals.cc>

<http://www.manual-lib.com>

<http://www.404manual.com>

<http://www.luxmanual.com>

<http://aubethermostatmanual.com>

Golf course search by state

<http://golfingnear.com>

Email search by domain

<http://emailbydomain.com>

Auto manuals search

<http://auto.somanuals.com>

TV manuals search

<http://tv.somanuals.com>