

Husqvarna®

Illustrated Parts List Pressure Washer / Lavadora de Presión Pressure Washer



This pressure washer is rated in accordance to the Pressure Washer Manufacture Association (PWMA) Standard PW101 (Testing and Rating Performance of Pressure Washers).

Questions? Help is just a moment away!
Preguntas? La ayuda es justa un momento lejos!
Call: Pressure Washer Helpline

Llame: Línea Directa del Lavadora a Presión - 1-877-224-0458 M-F 8-5 CT

Model / Modelo

Mfg. No.	Description / Descripción
020524-00	3,300 PSI Husqvarna

Manual Part No. 317992

Revision A

Rev. Date: 5/3/2012

PRODUCT COMPONENTS	PAGES
Main Unit	4
Pump	7
Torque Specification Chart Inside Back Cover

Not for
Reproduction

Main Unit

316335

NOTE: Unless noted otherwise, use the standard hardware torque specification chart.

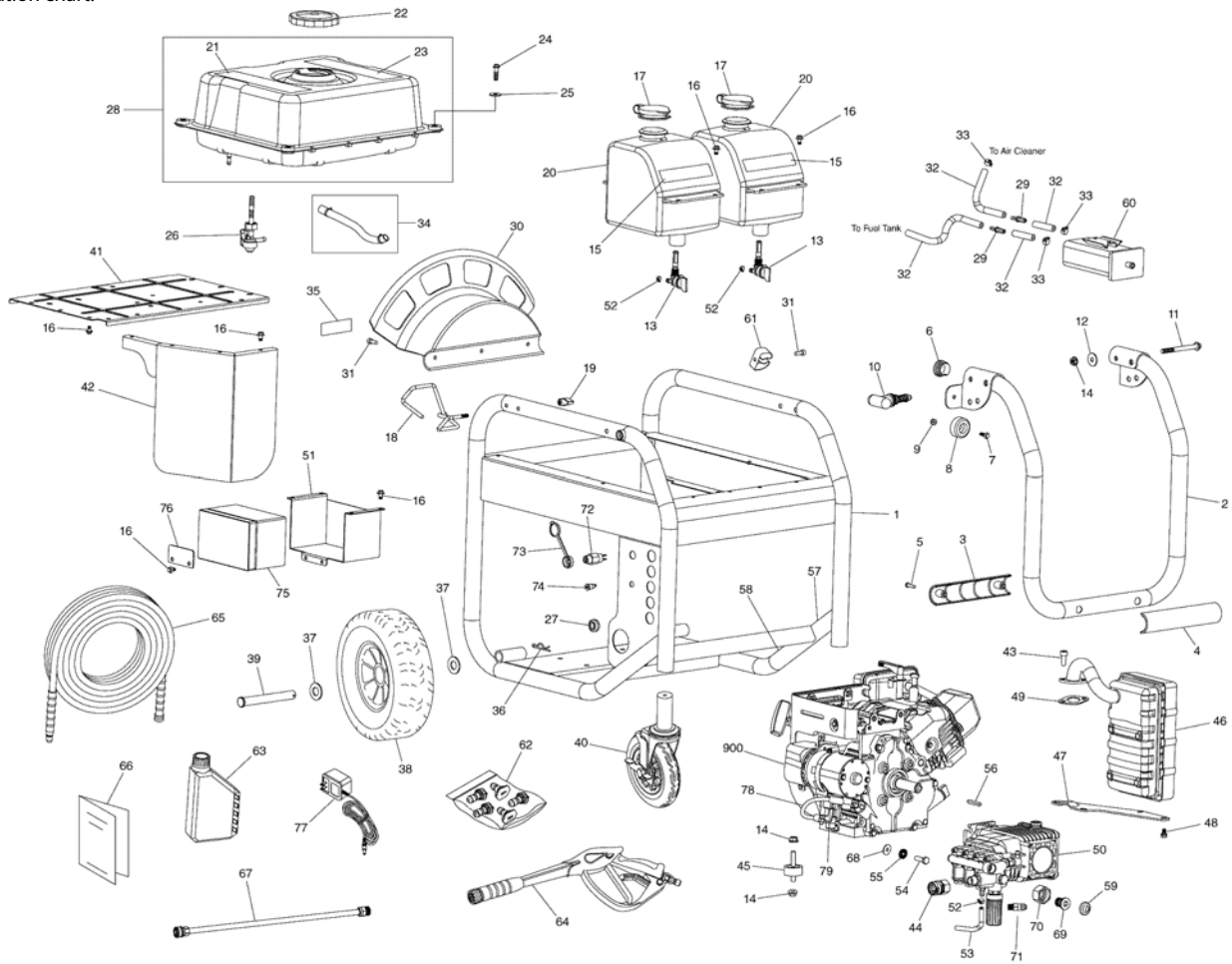

REF.	PART NO.	DESCRIPTION	REF.	PART NO.	DESCRIPTION
1	313250GS	BASE	18	316500GS	WIREFORM
2	313252GS	HANDLE	19	194289GS	KNOB
3	316502GS	GRIP, Handle	20	315530GS	TANK, Chemical
4	316501GS	GRIP, Handle	21	316723GS	DECAL
5	----	SCREW, M5-0.8 x 20	22	316670GS	CAP, Fuel
6	316712GS	CAP, Plug	23	316778GS	DECAL
7	----	SCREW, M6 x 18	24	----	SCREW, M6 x 25 HEX
8	316713GS	MOUNT, Vibration	25	312005GS	WASHER
9	----	NUT, M6 1.0	26	209417GS	VALVE, Fuel
10	316732GS	T-KNOB	27	30809GS	GROMMET
11	316508GS	SCREW	28	315531GS	TANK, Fuel
12	----	WASHER, Flat M8	29	317025GS	BARB, Hose
13	317106GS	VALVE, Chemical Tank	30	316374GS	WRAP, Hose
14	----	NUT, M8 FLANGE	31	----	SCREW, M6-1.0 x 16
15	316726GS	DECAL	32	315017GS	HOSE, Vapor (cut to fit)
16	----	SCREW, M6 x 10	33	48031JGS	CLAMP
17	316764GS	CAP, Chemical Tank			

Footnotes

* (Engine parts are available through your Enine Manufacturer)

The above parts group applies to the following Mfg. Nos.:
020524-00 - 3,300 PSI Hus qvarna

Main Unit

316335

NOTE: Unless noted otherwise, use the standard hardware torque specification chart.

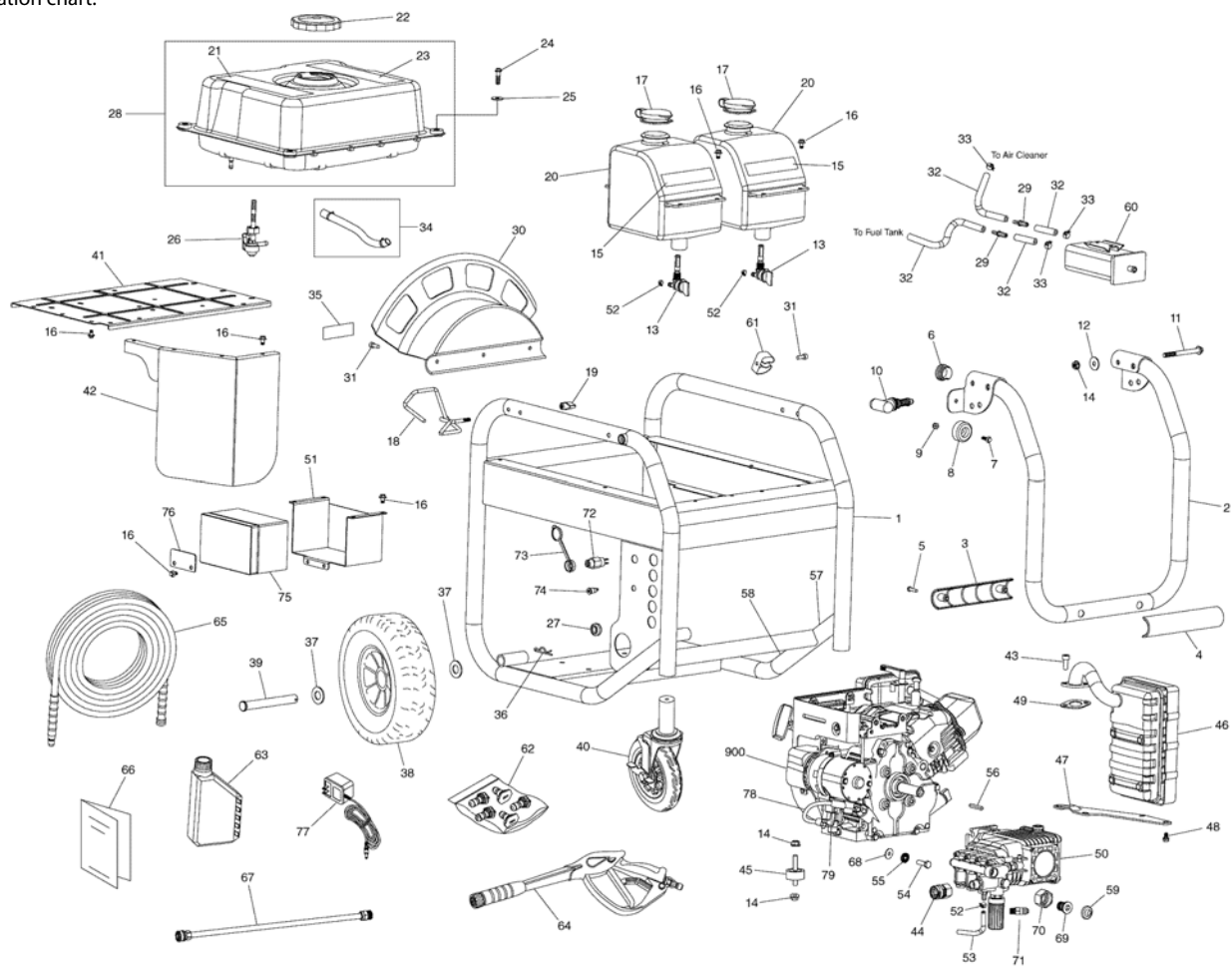

REF.	PART NO.	DESCRIPTION	REF.	PART NO.	DESCRIPTION
34	791745	KIT, Fuel Hose (cut to fit)	51	316511GS	TRAY-BATTERY
35	197798GS	DECAL	52	48031GGS	CLAMP
36	5025210YP	PIN, Hair	53	A1040DGS	HOSE-CHEMICAL
37	----	WASHER, Flat 5/8"	54	----	SCREW, 5/16-24 x 1
38	316406GS	WHEEL	55	92479GS	WASHER
39	317577GS	AXLE	56	23139DGS	KEY
40	316405GS	WHEEL, Caster	57	208538GS	DECAL
41	316504GS	HEATSHIELD	58	316727GS	DECAL
42	316505GS	HEATSHIELD	59	B2384GS	FILTER, Garden Hose
43	----	SCREW, M8 - 1.25 x 20	60	316783GS	CARBON CANISTER
44	95458GS	FITTING	61	316503GS	CLIP
45	21217GS	MOUNT, Vibration	62	208324GS	KIT, Nozzle
46	188301GS	MUFFLER	--	198841GS	NOZZLE, QC Black
47	191785GS	BRACKET, Muffler	--	195983NGS	NOZZLE, QC Red
48	----	SCREW, M6 1.0 x 12	--	195983QGS	NOZZLE, QC Green
49	697815	GASKET	--	195983PGS	NOZZLE, QC Yellow
50	317944GS	PUMP	--	195983RGS	NOZZLE, QC White

Footnotes

* (Engine parts are available through your Enine Manufacturer)

The above parts group applies to the following Mfg. Nos.:

020524-00 - 3,300 PSI Hus qvarna

Main Unit

316335

NOTE: Unless noted otherwise, use the standard hardware torque specification chart.

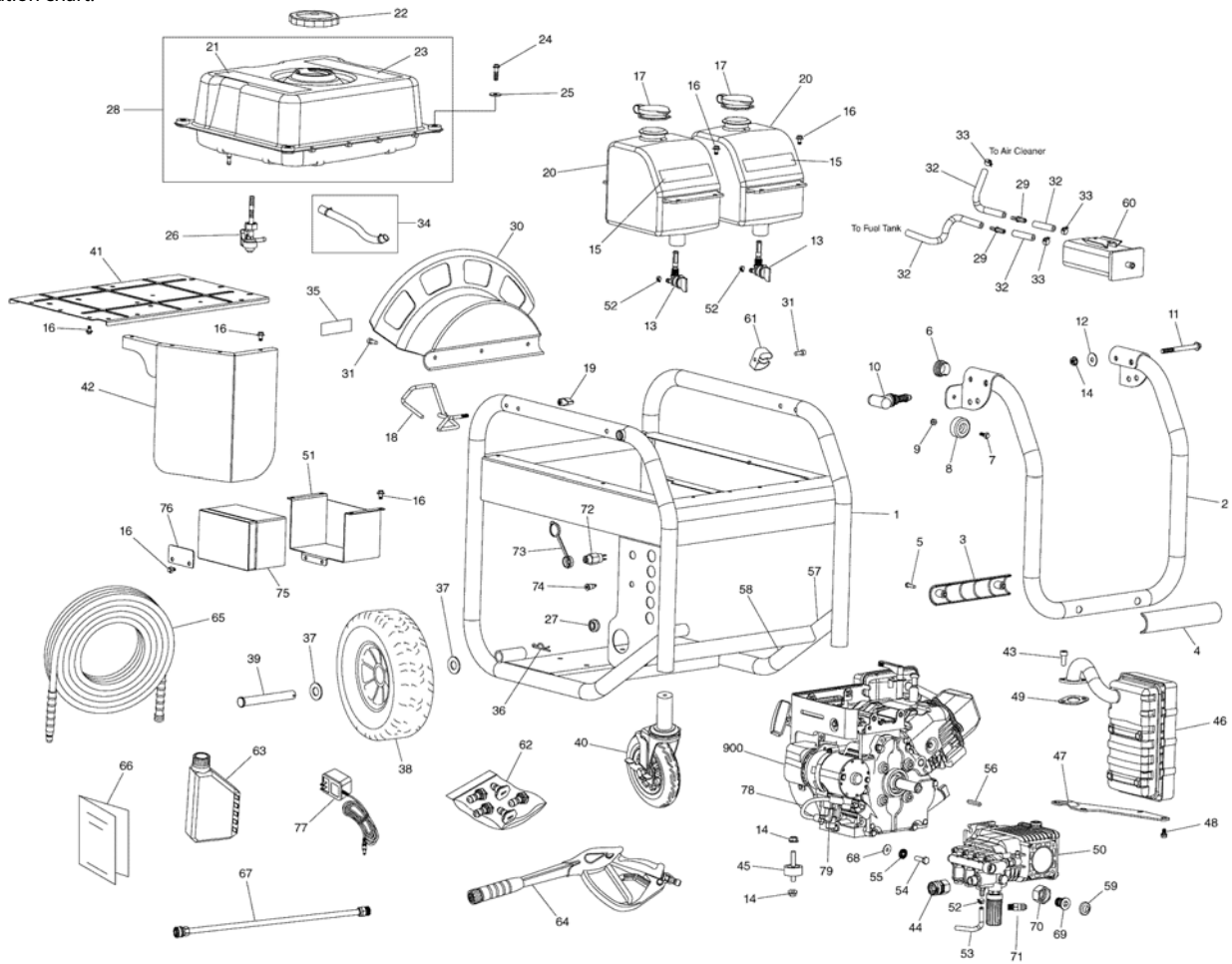

REF.	PART NO.	DESCRIPTION	REF.	PART NO.	DESCRIPTION
63	316768GS	OIL BOTTLE	900	----	ENGINE
64	316157GS	GUN	--	316782GS	WRENCH, Allen (Parts Not Illustrated)
65	316467GS	HOSE	--	317898GS	CABLE, Battery, Red (Parts Not Illustrated)
66	316333GS	MANUAL-OPERATOR	--	317943GS	CABLE, Battery, Black (Parts Not Illustrated)
67	207785GS	EXTENSION	--	601 40 00 76	KEY (Parts Not Illustrated)
68	----	WASHER, FLAT 5/16	--	317365GS	OIL FUNNEL (Parts Not Illustrated)
69	195894GS	FITTING	--	315546GS	KIT, Battery Hardware (Parts Not Illustrated)
70	195893GS	CONNECTOR	--	6039	PUMP SAVER (Optional Accessories)
71	208673GS	VALVE, Thermal Relief			
72	7028765YP	SWITCH			
73	312687GS	BOOT, Rubber			
74	208511GS	JACK, Coaxial			
75	316543GS	BATTERY			
76	316729GS	COVER, Battery			
77	B4177GS	CHARGER, Battery			
78	690795	CABLE ASSEMBLY			
79	557067	BRACKET SOLENOID ASSEMBLY			

Footnotes

* (Engine parts are available through your Enine Manufacturer)

The above parts group applies to the following Mfg. Nos.:

020524-00 - 3,300 PSI Hus qvarna

Pump

316158

NOTE: Unless noted otherwise, use the standard hardware torque specification chart.

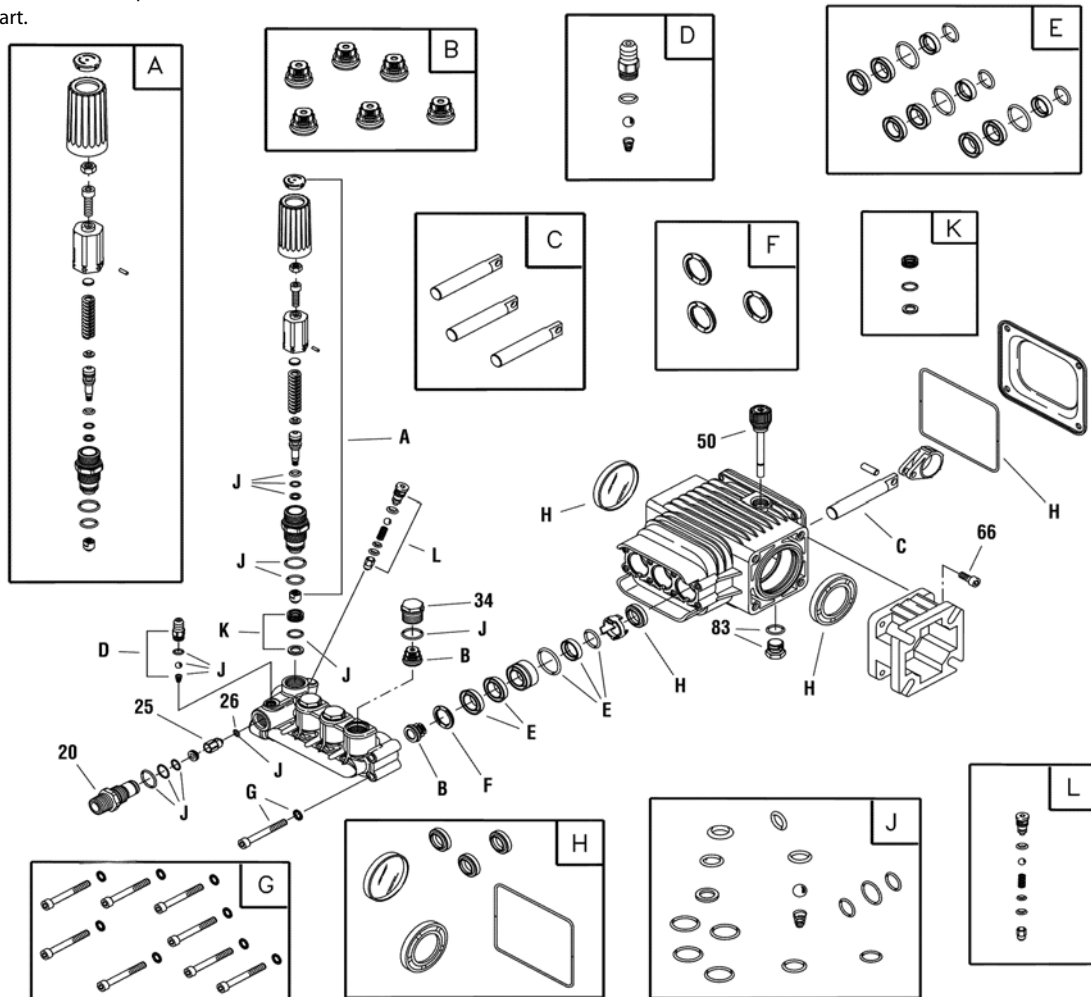

REF.	PART NO.	DESCRIPTION	REF.	PART NO.	DESCRIPTION
20	198851GS	INJECTOR, Detergent	L	202800GS	KIT, Unloader
25	204860GS	JET	--	B2384GS	FILTER, Garden Hose (Parts Not Illustrated)
26	204859GS	O-RING	--	6039	PUMP SAVER (Optional Accessories)
34	198850GS	CAP, Check Valve			
50	198849GS	DIPSTICK			
66	198297GS	SCREW			
83	203034GS	PLUG, Drain			
A	198736GS	KIT, Unloader			
B	198843GS	KIT, Check Valve			
C	198844GS	KIT, Piston			
D	192914GS	KIT, Chemical Injector			
E	198845GS	KIT, Water Seal			
F	198848GS	KIT, Support Ring			
G	198852GS	KIT, Hardware			
H	198846GS	KIT, Oil Seals			
J	198847GS	KIT, O-Ring			
K	202902GS	KIT, Unloader Seat			

Footnotes

The above parts group applies to the following Mfg. Nos.:

020524-00 - 3,300 PSI Hus qvarna

Hardware Identification & Torque Specifications

Torque Specification Chart FOR STANDARD METRIC MACHINE HARDWARE (Tolerance ± 20%)								
Property Class	5.6 Class 5.6		8.8 Class 8.8		10.9 Class 10.9		12.9 Class 12.9	
	in/lbs ft/lbs	Nm.	in/lbs ft/lbs	Nm.	in/lbs ft/lbs	Nm.	in/lbs ft/lbs	Nm.
M3	5.88	.56	13.44	1.28	19.2	1.80	22.92	2.15
M4	13.44	1.28	30.72	2.90	43.44	4.10	52.56	4.95
M5	26.4	2.50	60.96	5.75	5.97	8.10	7.15	9.7
M6	44.64	4.3	7.3	9.9	10.3	14	12.1	16.5
M7	5.2	7.1	12.1	16.5	16.9	23	19.9	27
M8	7.7	10.5	17.7	24	25	34	29	40
M10	15	21	35	48	50	67	59	81
M12	26	36	61	83	86.2	117	103	140
M14	42	58	101	132	136	185	162	220
M16	64	88	147	200	210	285	250	340
M18	89	121	202	275	287	390	346	470
M20	126	171	290	390	405	550	486	660
M22	169	230	390	530	559	745	656	890
M24	217	295	497	375	708	960	840	1140
M27	320	435	733	995	1032	1400	1239	1680
M30	435	590	995	1350	1401	1900	1681	2280
M33	590	800	1349	1830	1902	2580	2278	3090
M36	759	1030	1740	2360	2441	3310	2935	3980
M39	988	1340	2249	3050	3163	4290	3798	5150

The guides and ruler furnished below are designed to help you select the appropriate hardware.

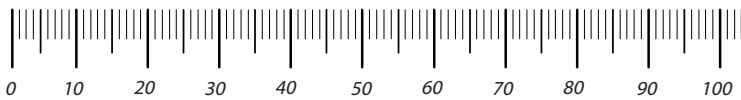

Nut, M8

Thread Diameter (mm)
Inside Diameter (in)
Threads per inch

Nut, 1/2-16

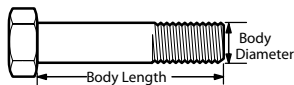

Screw, M8- 1.25 x 25

Thread Diameter (mm)
Body Diameter
Distance between threads (mm)
Threads per inch
Body Length (mm)
Body Length (in)

Screw, 1/2- 16 x 2

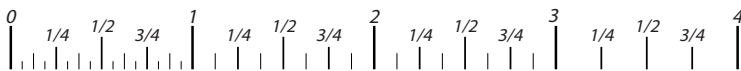

Standard Hardware Sizing

When a washer or nut is identified as 1/2" (M8), this is the *Nominal size*, meaning the *inside diameter* is 1/2 inch (8mm metric thread diameter); if a second number is present it represents the *threads per inch* (distance between threads).

When bolt or capscrew is identified as 1/2 - 16 x 2" (M8 - 1.25 x 50), this means the *Nominal size*, or body diameter is 1/2 inch (8mm metric thread diameter), the second number, 16, represents the *threads per inch*, (1.25 thread diameter). The final number is the body length of the bolt or screw, 2 inches (50mm).

Torque Specification Chart FOR STANDARD MACHINE HARDWARE (Tolerance ± 20%)						
Hardware Grade	No Marks SAE Grade 2		SAE Grade 5		SAE Grade 8	
	in/lbs ft/lbs	Nm.	in/lbs ft/lbs	Nm.	in/lbs ft/lbs	Nm.
8-32	19	2.1	30	3.4	41	4.6
8-36	20	2.3	31	3.5	43	4.9
10-24	27	3.1	43	4.9	60	6.8
10-32	31	3.5	49	5.5	68	7.7
1/4-20	66	7.6	8	10.9	12	16.3
1/4-28	76	8.6	10	13.6	14	19.0
5/16-18	11	15.0	17	23.1	25	34.0
5/16-24	12	16.3	19	25.8	29	34.0
3/8-16	20	27.2	30	40.8	45	61.2
3/8-24	23	31.3	35	47.6	50	68.0
7/16-14	30	40.8	50	68.0	70	95.2
7/16-20	35	47.6	55	74.8	80	108.8
1/2-13	50	68.0	75	102.0	110	149.6
1/2-20	55	74.8	90	122.4	120	163.2
9/16-12	65	88.4	110	149.6	150	204.0
9/16-18	75	102.0	120	163.2	170	231.2
5/8-11	90	122.4	150	204.0	220	299.2
5/8-18	100	136	180	244.8	240	326.4
3/4-10	160	217.6	260	353.6	386	525.0
3/4-16	180	244.8	300	408.0	420	571.2
7/8-9	140	190.4	400	544.0	600	816.0
7/8-14	155	210.8	440	598.4	660	897.6
1-8	220	299.2	580	788.8	900	1,244.0
1-12	240	326.4	640	870.4	1,000	1,360.0

NOTES

- These torque values are to be used for all hardware excluding: locknuts, self-tapping screws, thread forming screws, sheet metal screws and socket head setscrews.
- Recommended seating torque values for locknuts:
 - for prevailing torque locknuts - use 65% of grade 5 torques.
 - for flange whizlock nuts and screws - use 135% of grade 5 torques.
- Unless otherwise noted on assembly drawings, all torque values must meet this specification.

Common Hardware Types

Hex Head Capscrew



Washer



Lockwasher

Carriage Bolt

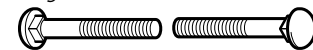

Hex Nut

Wrench & Fastener Size Guide



1/4" Bolt or Nut
Wrench—7/16"



5/16" Bolt or Nut
Wrench—1/2"



3/8" Bolt or Nut
Wrench—9/16"



7/16" Bolt or Nut
Wrench (Bolt)—5/8"
Wrench (Nut)—11/16"



1/2" Bolt or Nut
Wrench—3/4"

M6 Bolt or Nut
Wrench—10mm

M8 Bolt or Nut
Wrench—13mm

M10 Bolt or Nut
Wrench—17mm

M12 Bolt or Nut
Wrench—19mm

M14 Bolt or Nut
Wrench—22mm



Not for
Reproduction

Briggs & Stratton Power Products Group, LLC

Copyright© 2012 Briggs & Stratton Power Products Group, LLC. All rights reserved. No part of this page can be produced or transmitted in any form by any means without the express written permission of Briggs & Stratton Power Products Group, LLC.

Free Manuals Download Website

<http://myh66.com>

<http://usermanuals.us>

<http://www.somanuals.com>

<http://www.4manuals.cc>

<http://www.manual-lib.com>

<http://www.404manual.com>

<http://www.luxmanual.com>

<http://aubethermostatmanual.com>

Golf course search by state

<http://golfingnear.com>

Email search by domain

<http://emailbydomain.com>

Auto manuals search

<http://auto.somanuals.com>

TV manuals search

<http://tv.somanuals.com>